

MONO DE EJES
SIN ESCALA

EJE 1 (HOJA 03 DE 22)

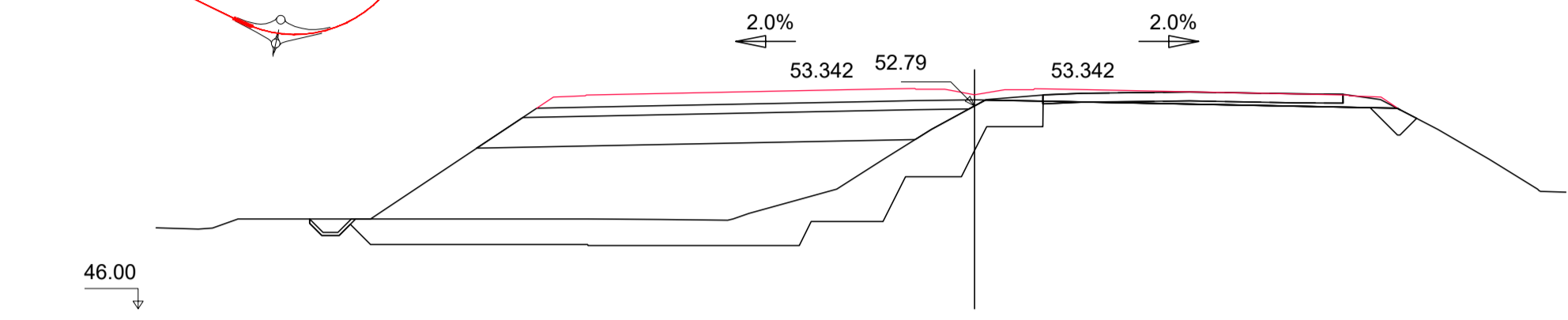

Pk=0+640
 S. FIRME = 11.11 m². S. TERRAPLEN = 34.60 m². S. DEMOLICION = 2.95 m².
 S. D TIERRA = 2.10 m². S. REV CUN GUARDA = 0.19 m².
 S. SUELO ADEC = 14.78 m². S. EXCAVA SANEIO = 25.06 m².
 S. SUELO S-EST3 = 4.50 m². S. TERRAP SANEIO = 25.06 m².

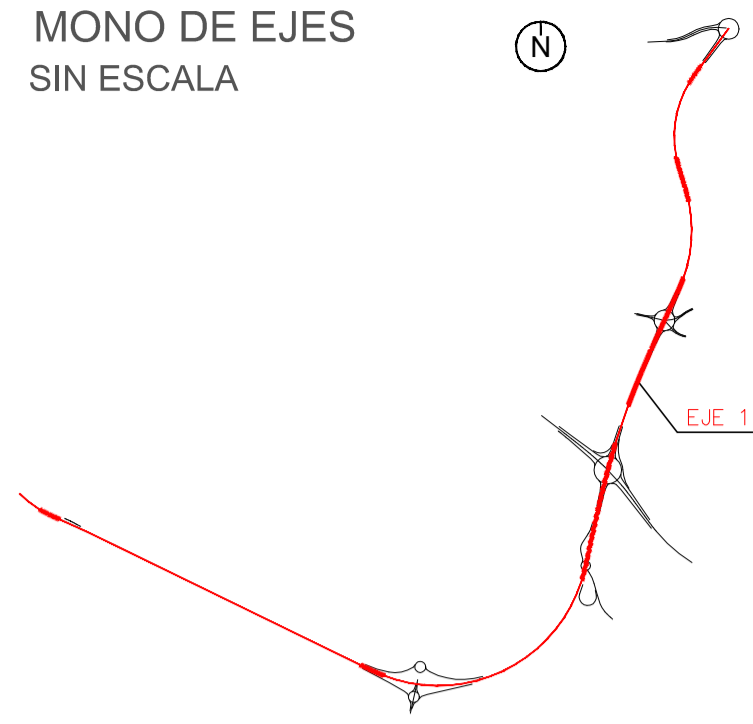
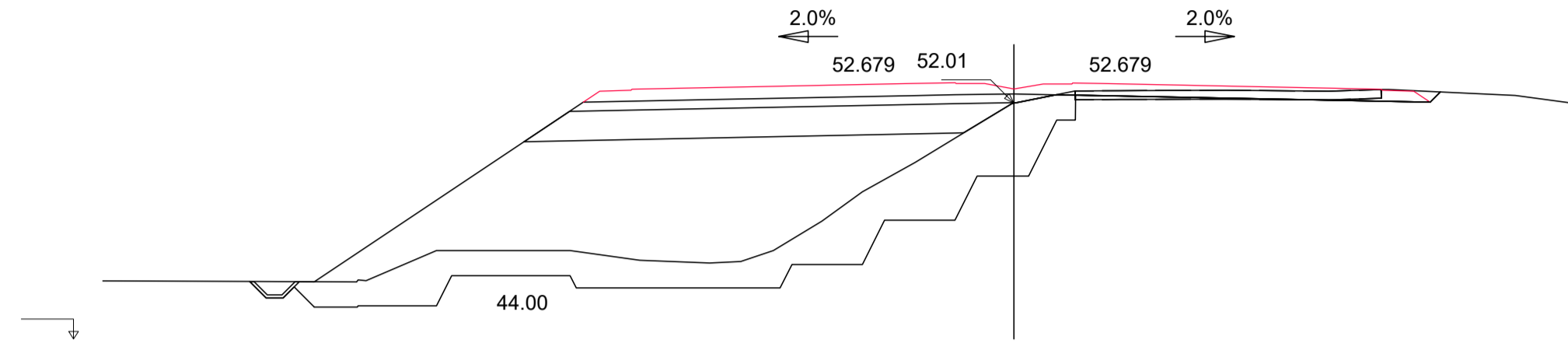

Pk=0+720
 S. FIRME = 11.11 m². S. TERRAPLEN = 58.96 m². S. DEMOLICION = 2.60 m².
 S. D TIERRA = 1.48 m². S. REV CUN GUARDA = 0.20 m².
 S. SUELO ADEC = 15.03 m². S. EXCAVA SANEIO = 34.99 m².
 S. SUELO S-EST3 = 4.69 m². S. TERRAP SANEIO = 35.00 m².

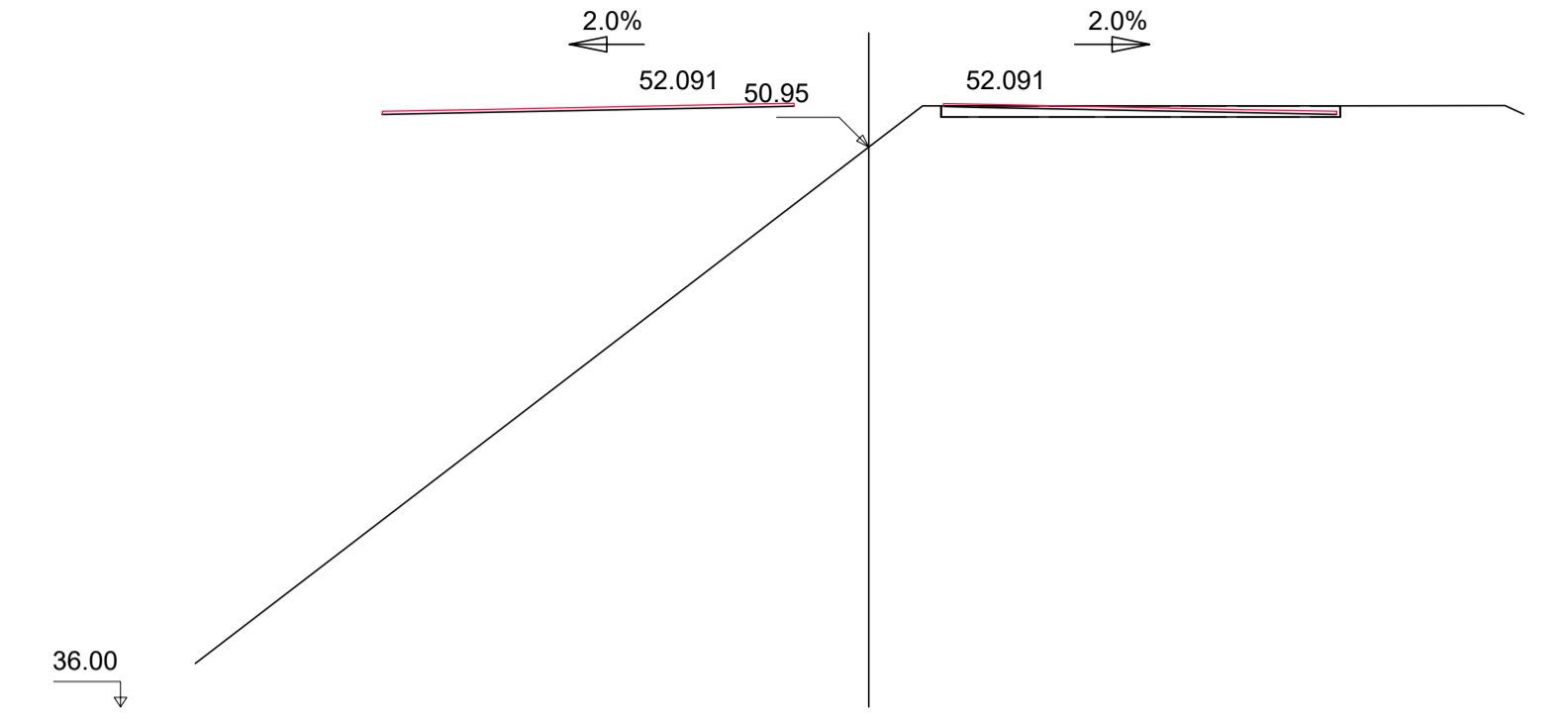

Pk=0+800
 S. FIRME = 1.72 m².

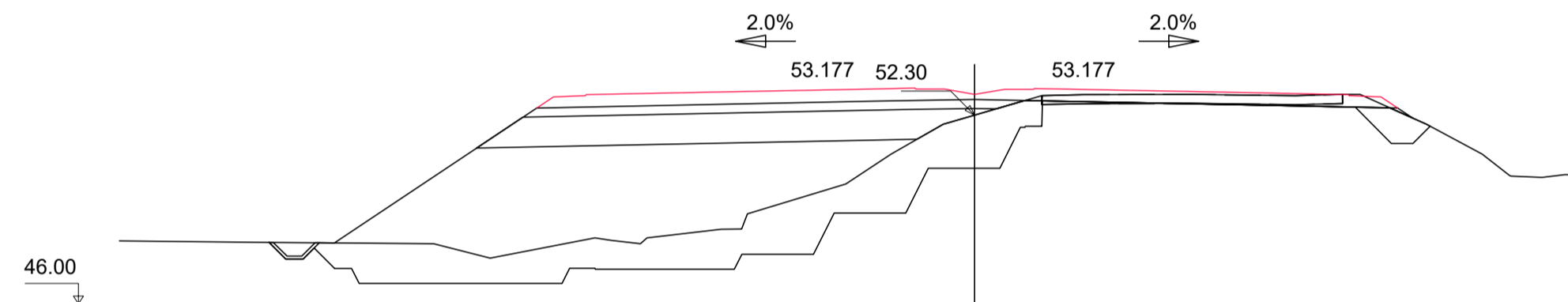

Pk=0+660
 S. FIRME = 11.11 m². S. TERRAPLEN = 44.92 m². S. DEMOLICION = 2.80 m².
 S. D TIERRA = 1.39 m². S. REV CUN GUARDA = 0.20 m².
 S. SUELO ADEC = 15.10 m². S. EXCAVA SANEIO = 32.74 m².
 S. SUELO S-EST3 = 4.87 m². S. TERRAP SANEIO = 32.74 m².

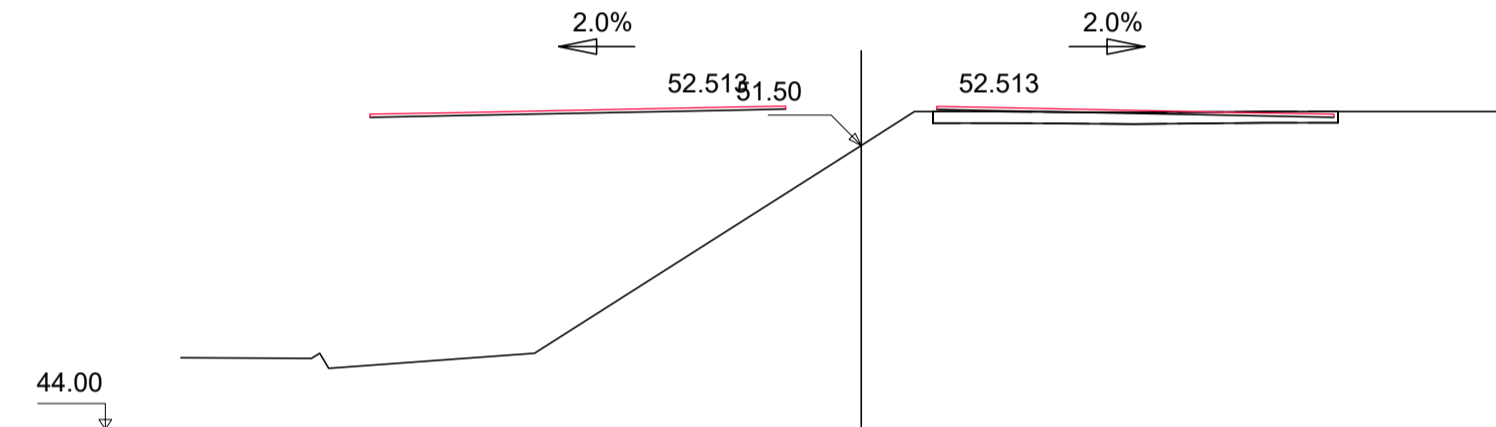

Pk=0+740
 S. FIRME = 1.72 m².

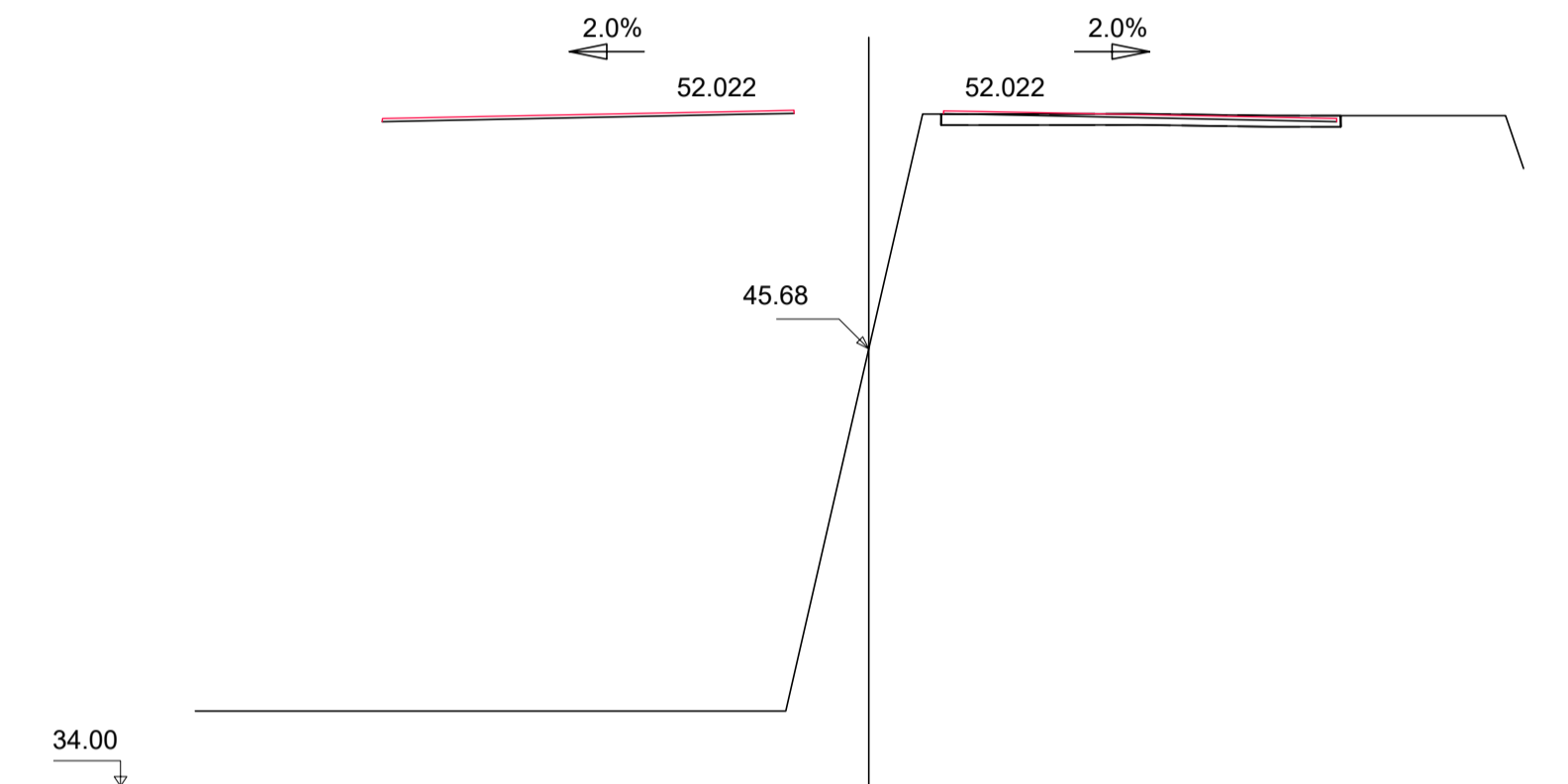

Pk=0+820
 S. FIRME = 1.72 m².

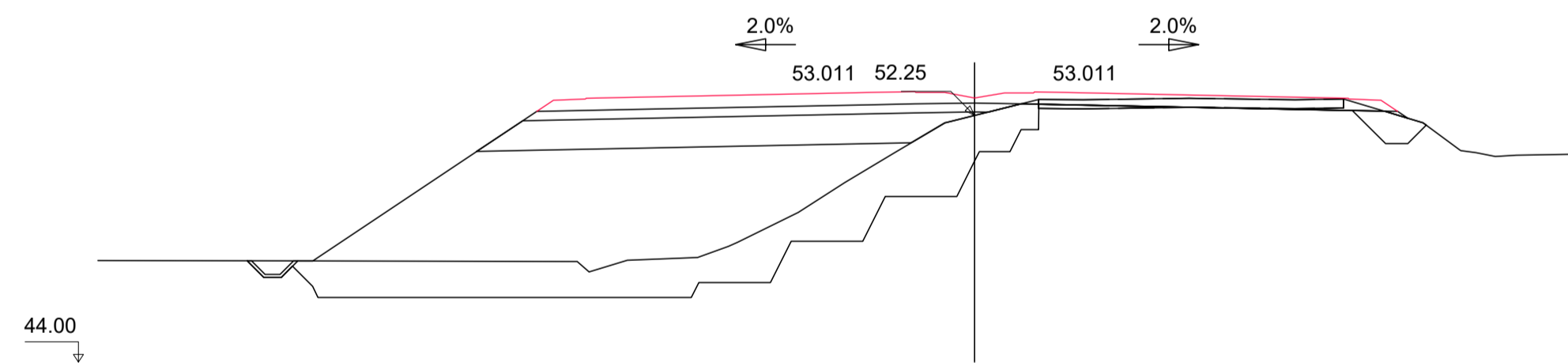

Pk=0+680
 S. FIRME = 11.11 m². S. TERRAPLEN = 52.26 m². S. DEMOLICION = 2.66 m².
 S. D TIERRA = 1.05 m². S. REV CUN GUARDA = 0.20 m².
 S. SUELO ADEC = 14.79 m². S. EXCAVA SANEIO = 35.16 m².
 S. SUELO S-EST3 = 4.81 m². S. TERRAP SANEIO = 35.16 m².

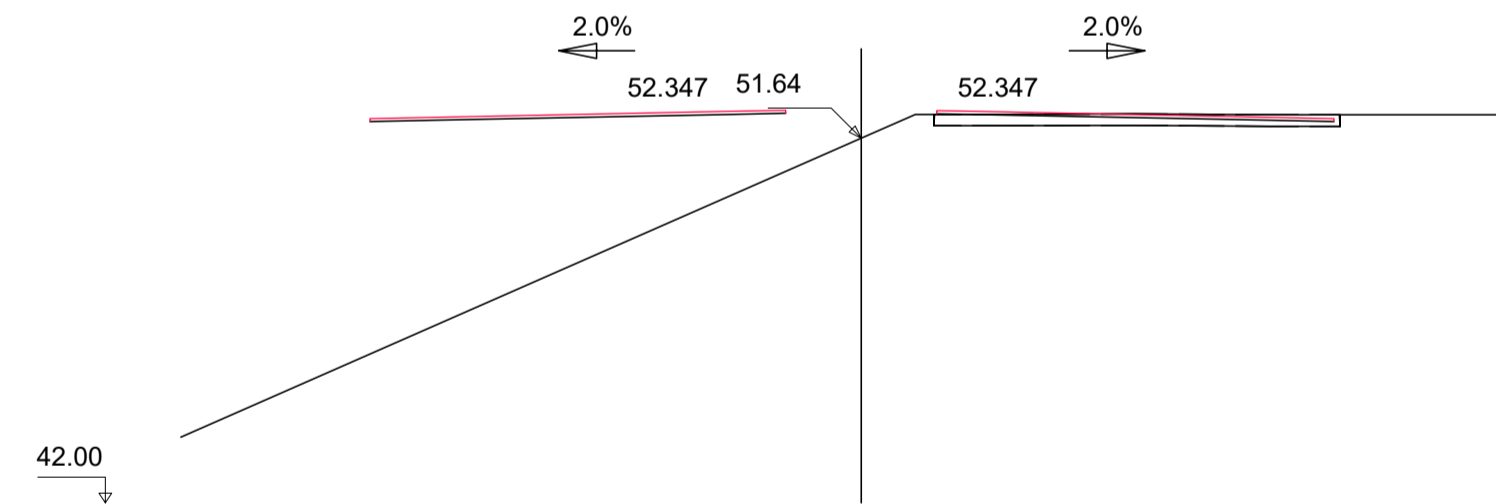

Pk=0+760
 S. FIRME = 1.72 m².

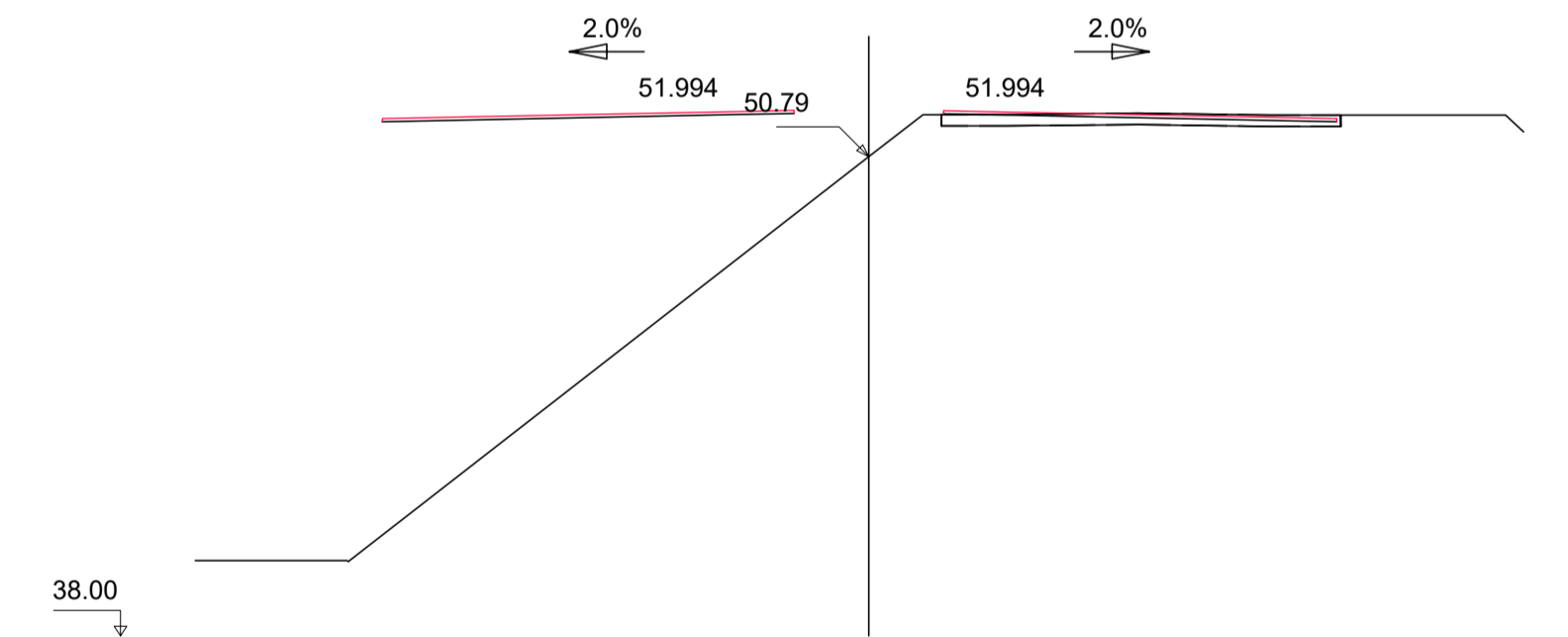

Pk=0+840
 S. FIRME = 1.72 m².

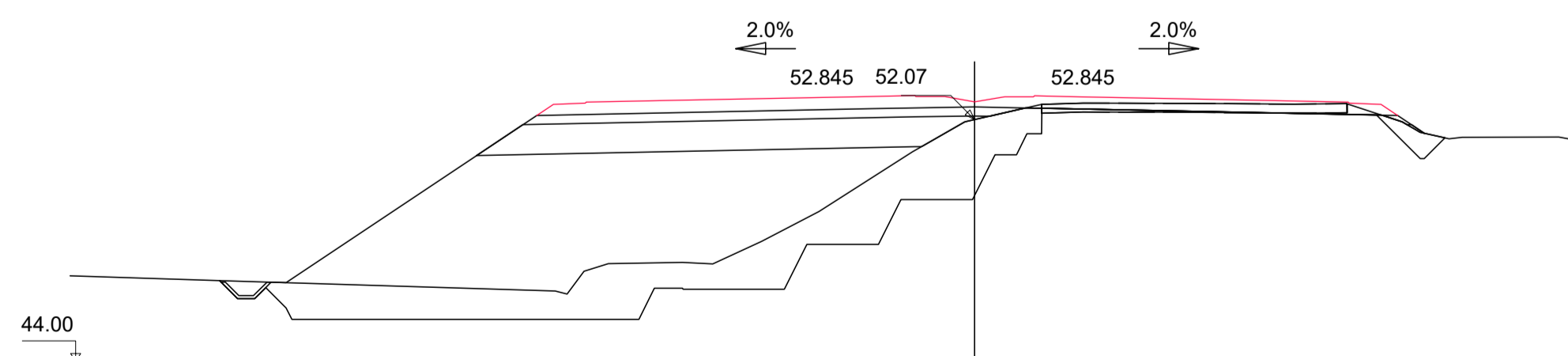

Pk=0+700
 S. FIRME = 11.11 m². S. TERRAPLEN = 60.57 m². S. DEMOLICION = 2.59 m².
 S. D TIERRA = 0.97 m². S. REV CUN GUARDA = 0.20 m².
 S. SUELO ADEC = 15.09 m². S. EXCAVA SANEIO = 36.06 m².
 S. SUELO S-EST3 = 4.89 m². S. TERRAP SANEIO = 36.06 m².

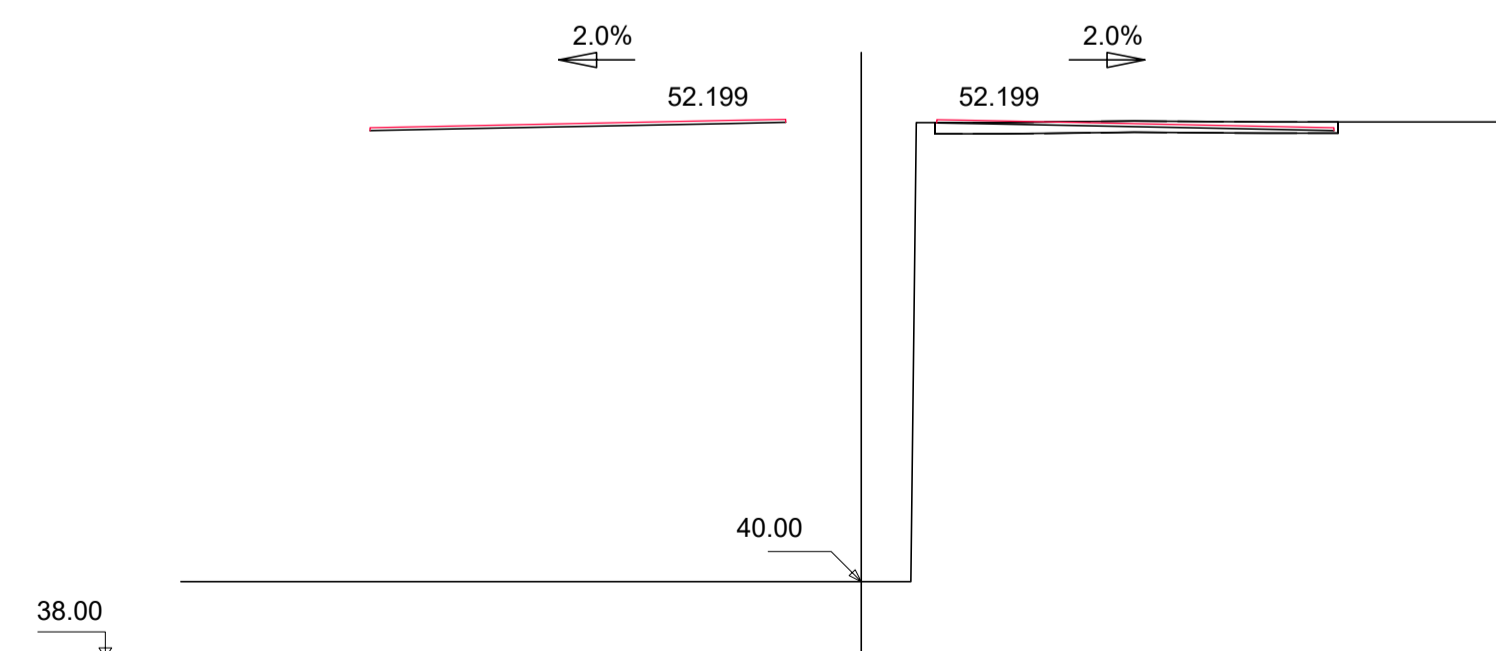

Pk=0+780
 S. FIRME = 1.72 m².

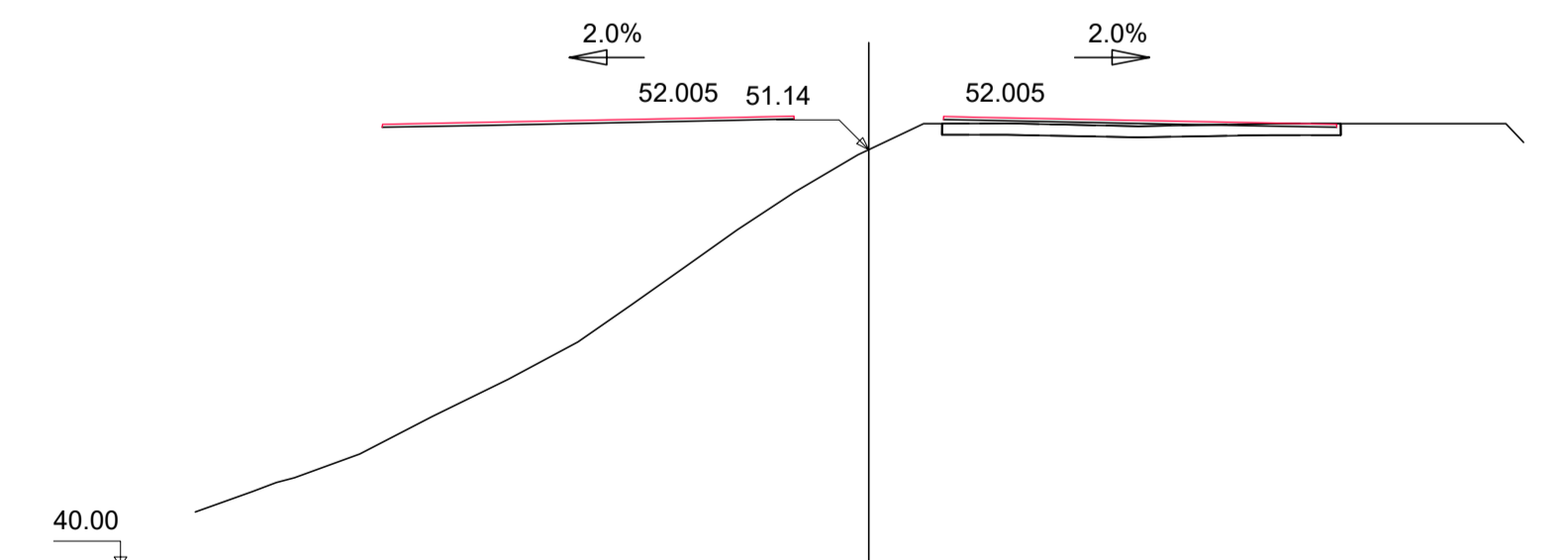

Pk=0+860
 S. FIRME = 1.72 m².

MONO DE EJES
SIN ESCALA

EJE 1 (HOJA 04 DE 22)

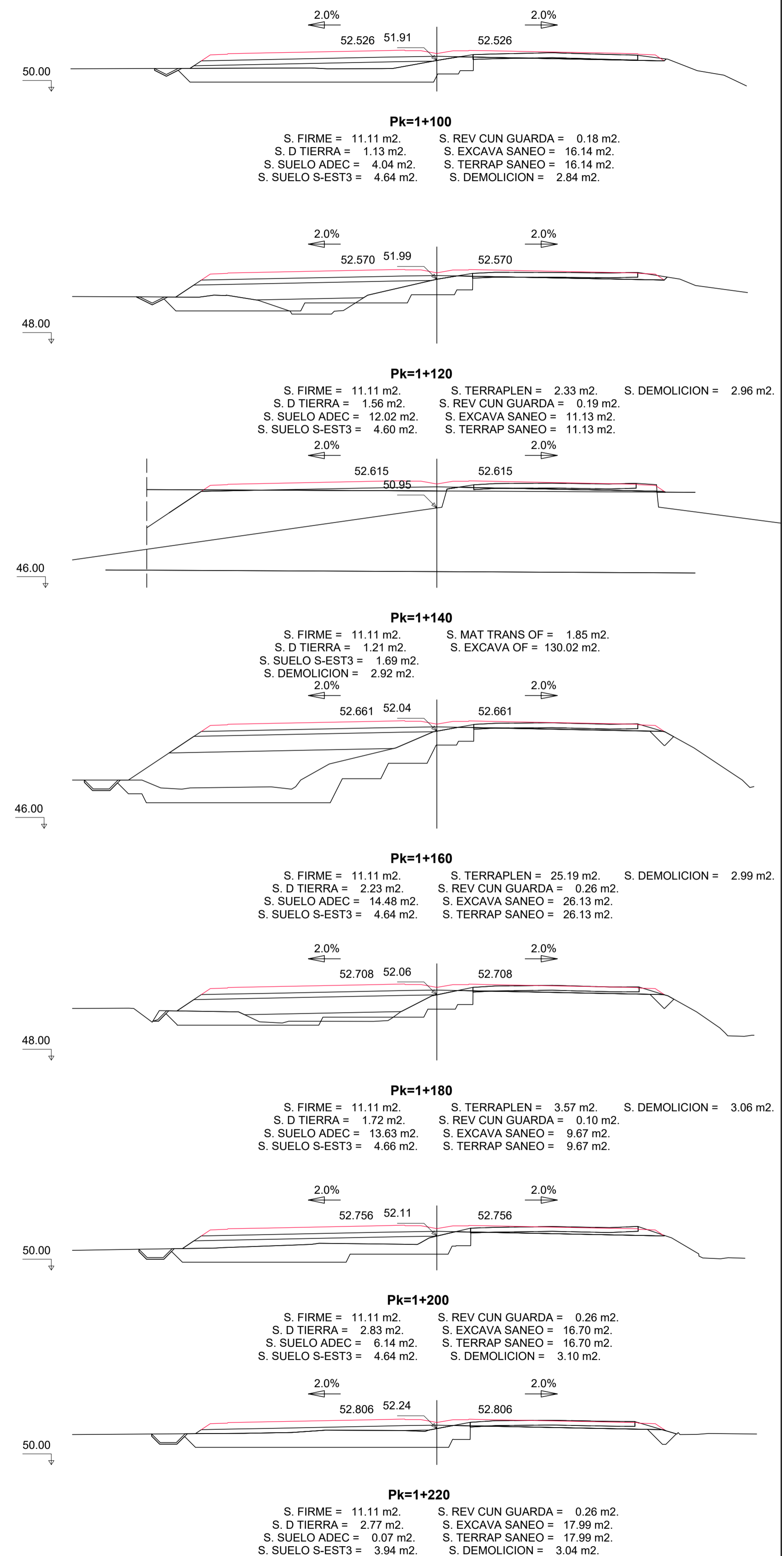
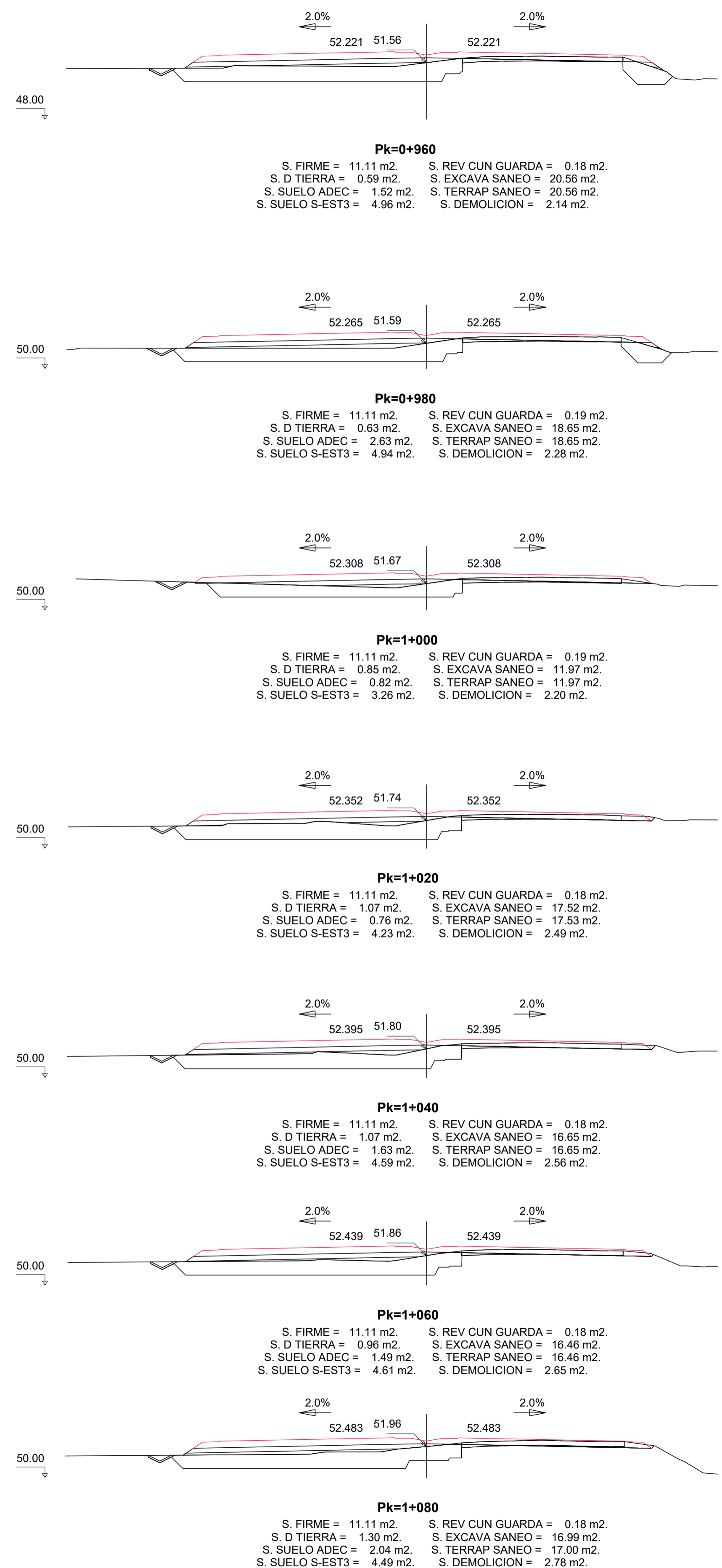
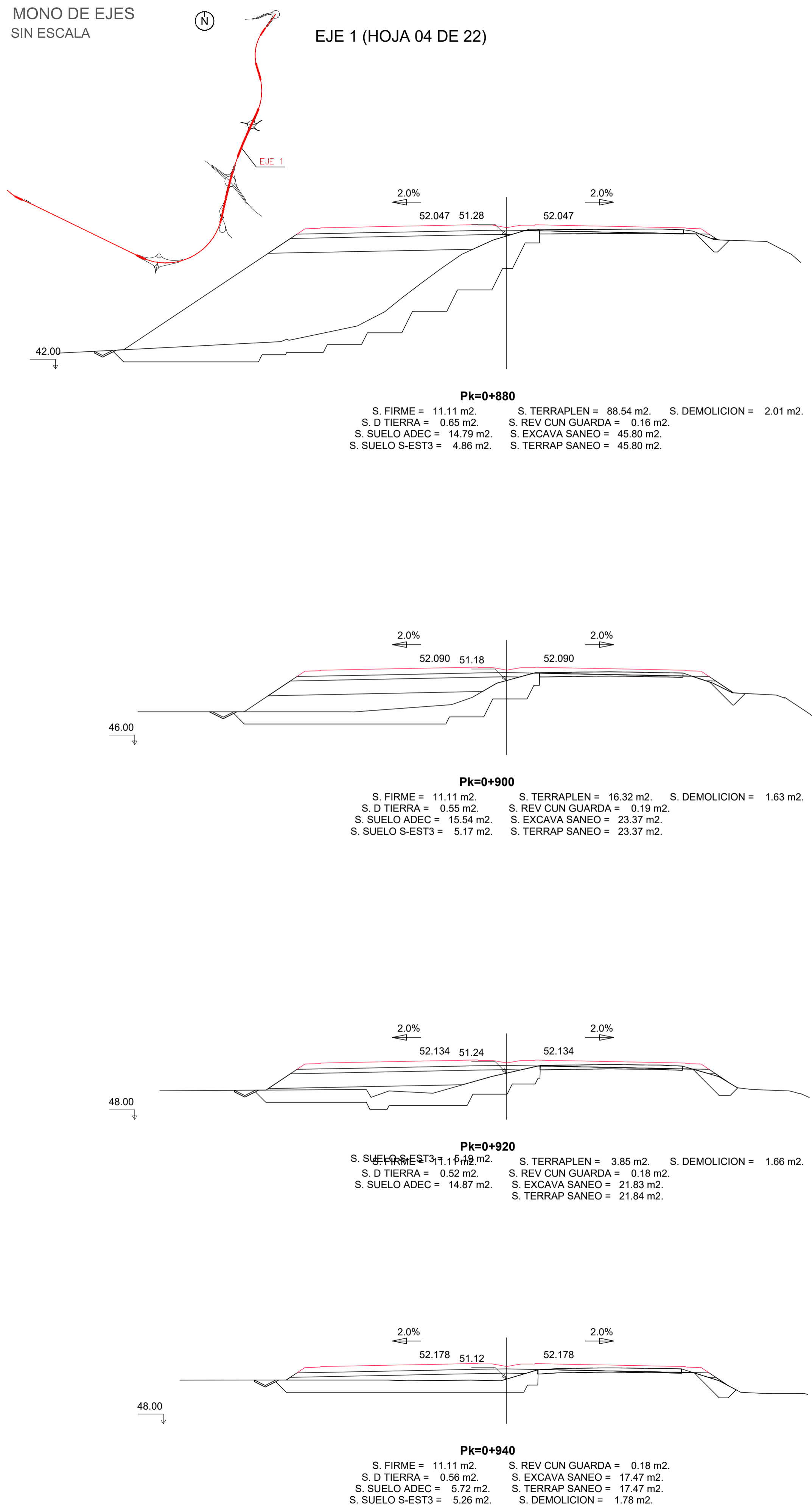

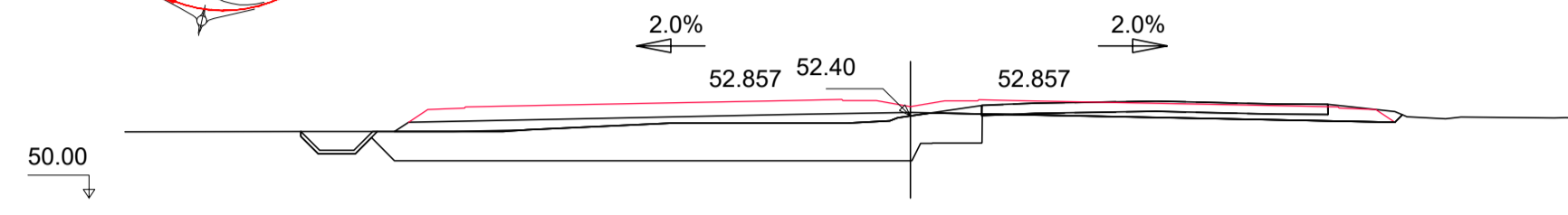
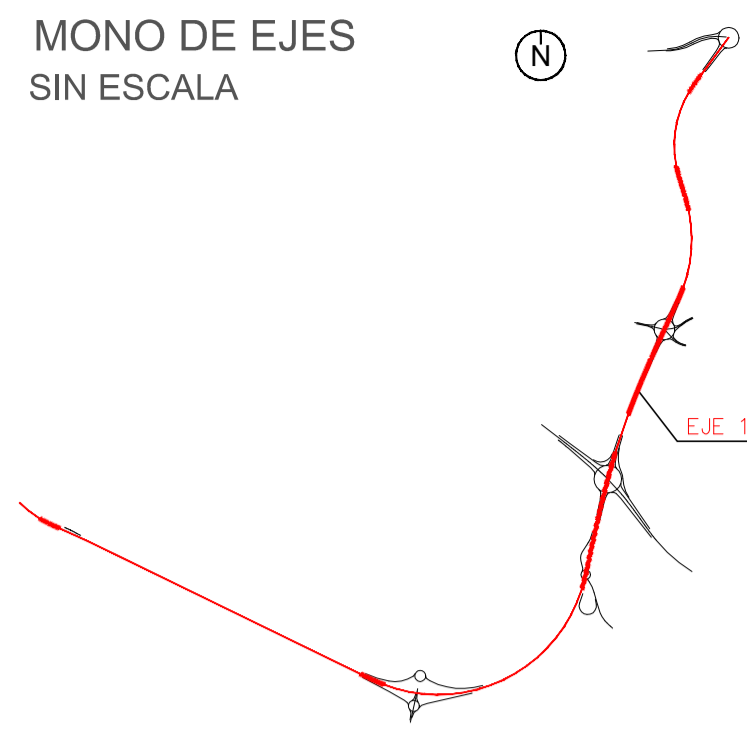

Pk=1+240
 S. FIRME = 11.11 m2. S. REV CUN GUARDA = 0.26 m2.
 S. D TIERRA = 3.36 m2. S. EXCAVA SANEO = 17.54 m2.
 S. SUELO ADEC = 0.03 m2. S. TERRAP SANEO = 17.54 m2.
 S. SUELO S-EST3 = 3.72 m2. S. DEMOLICION = 3.02 m2.

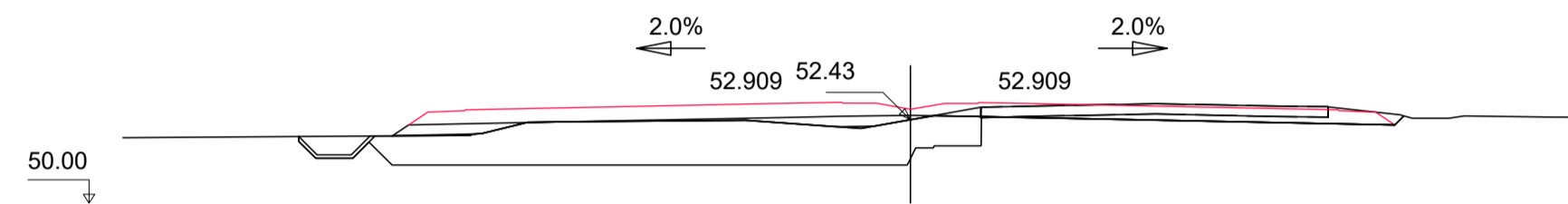

Pk=1+260
 S. FIRME = 11.11 m2. S. REV CUN GUARDA = 0.26 m2.
 S. D TIERRA = 3.45 m2. S. EXCAVA SANEO = 19.76 m2.
 S. SUELO ADEC = 0.10 m2. S. TERRAP SANEO = 19.76 m2.
 S. SUELO S-EST3 = 2.15 m2. S. DEMOLICION = 3.04 m2.

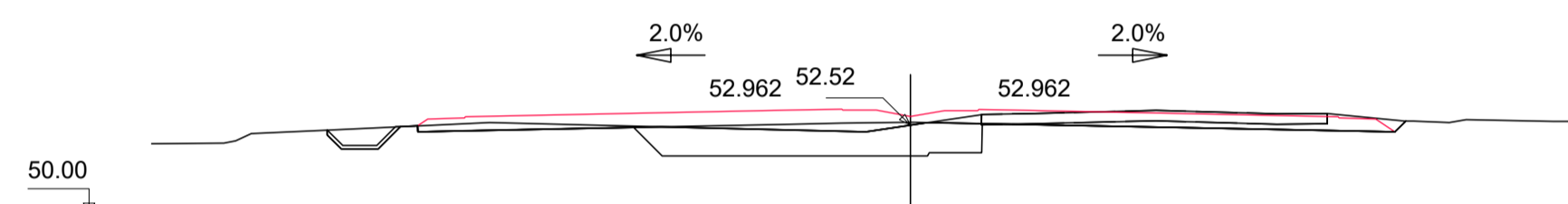

Pk=1+280
 S. FIRME = 11.09 m2. S. EXCAVA SANEO = 7.86 m2.
 S. D TIERRA = 4.31 m2. S. TERRAP SANEO = 7.86 m2.
 S. SUELO ADEC = 1.06 m2. S. DEMOLICION = 3.02 m2.
 S. REV CUN GUARDA = 0.25 m2.

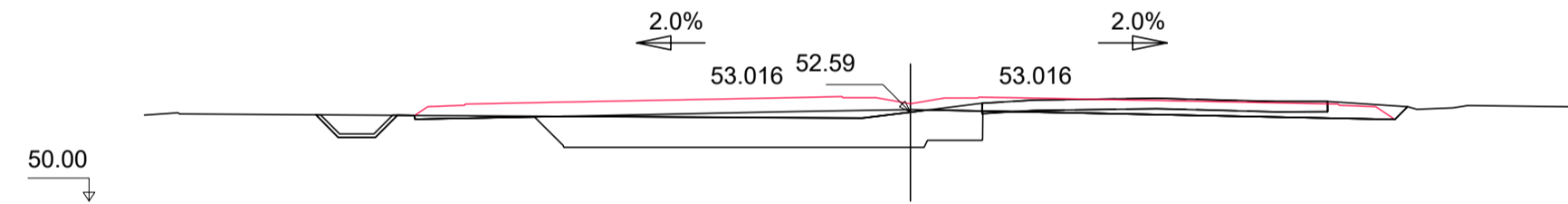

Pk=1+300
 S. FIRME = 11.10 m2. S. EXCAVA SANEO = 11.26 m2.
 S. D TIERRA = 3.74 m2. S. TERRAP SANEO = 11.26 m2.
 S. SUELO ADEC = 1.23 m2. S. DEMOLICION = 3.00 m2.
 S. REV CUN GUARDA = 0.27 m2.

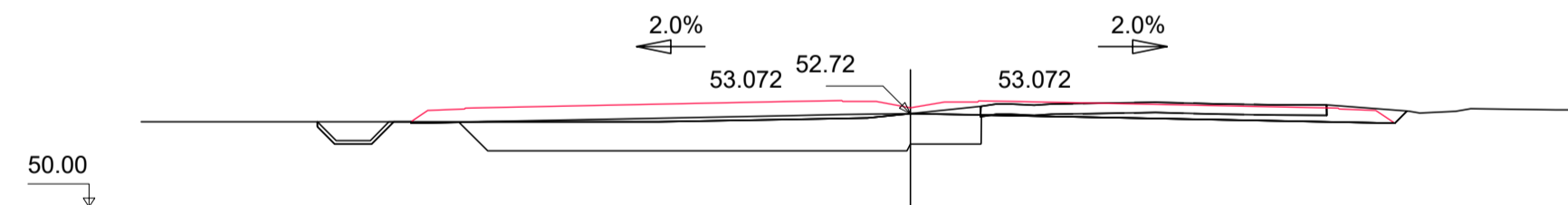

Pk=1+320
 S. FIRME = 11.11 m2. S. EXCAVA SANEO = 13.19 m2.
 S. D TIERRA = 3.62 m2. S. TERRAP SANEO = 13.19 m2.
 S. SUELO ADEC = 0.97 m2. S. DEMOLICION = 3.03 m2.
 S. REV CUN GUARDA = 0.26 m2.

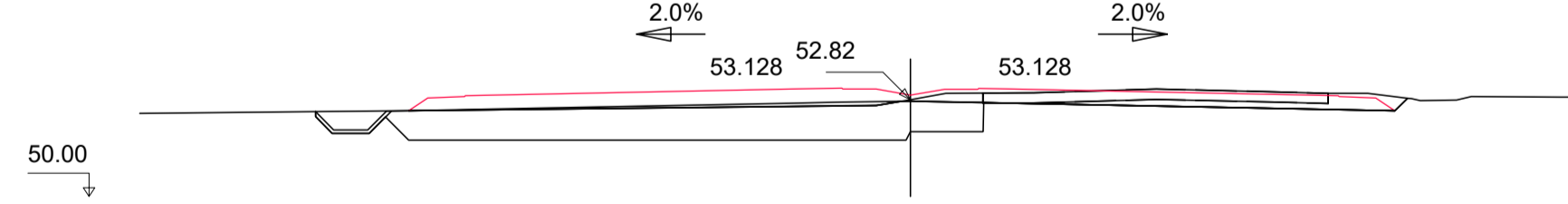

Pk=1+340
 S. FIRME = 11.11 m2. S. EXCAVA SANEO = 15.94 m2.
 S. D TIERRA = 3.81 m2. S. TERRAP SANEO = 15.94 m2.
 S. SUELO ADEC = 0.85 m2. S. DEMOLICION = 3.02 m2.
 S. REV CUN GUARDA = 0.26 m2.

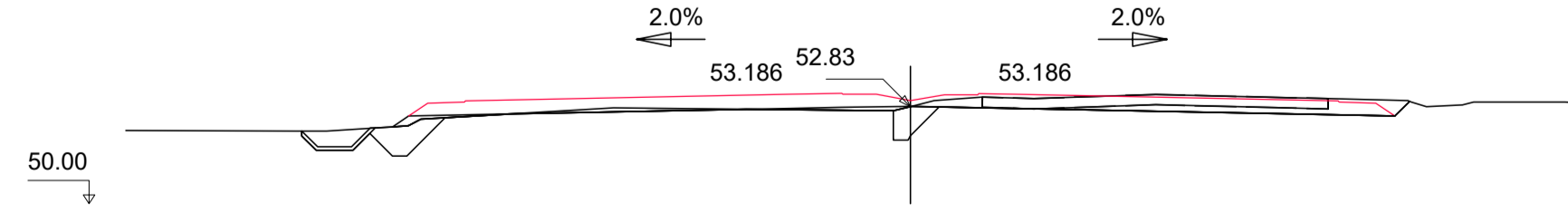

Pk=1+360
 S. FIRME = 11.11 m2. S. EXCAVA SANEO = 2.04 m2.
 S. D TIERRA = 4.04 m2. S. TERRAP SANEO = 2.04 m2.
 S. SUELO ADEC = 0.57 m2. S. DEMOLICION = 3.03 m2.
 S. REV CUN GUARDA = 0.25 m2.

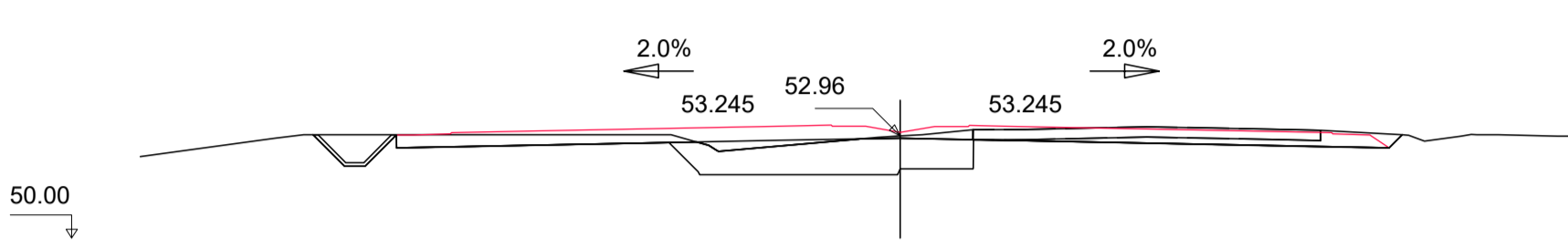

Pk=1+380
 S. FIRME = 11.19 m2. S. EXCAVA SANEO = 7.41 m2.
 S. REVES CUNETAS = 0.30 m2. S. TERRAP SANEO = 7.41 m2.
 S. D TIERRA = 6.53 m2. S. DEMOLICION = 3.02 m2.
 S. SUELO S-EST3 = 0.68 m2.

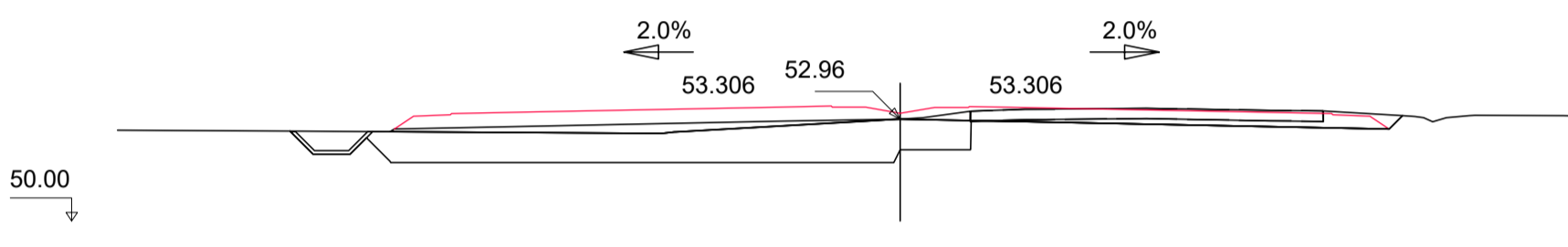

Pk=1+400
 S. FIRME = 11.11 m2. S. EXCAVA SANEO = 16.32 m2.
 S. D TIERRA = 3.60 m2. S. TERRAP SANEO = 16.32 m2.
 S. SUELO ADEC = 2.36 m2. S. DEMOLICION = 3.06 m2.
 S. REV CUN GUARDA = 0.27 m2.

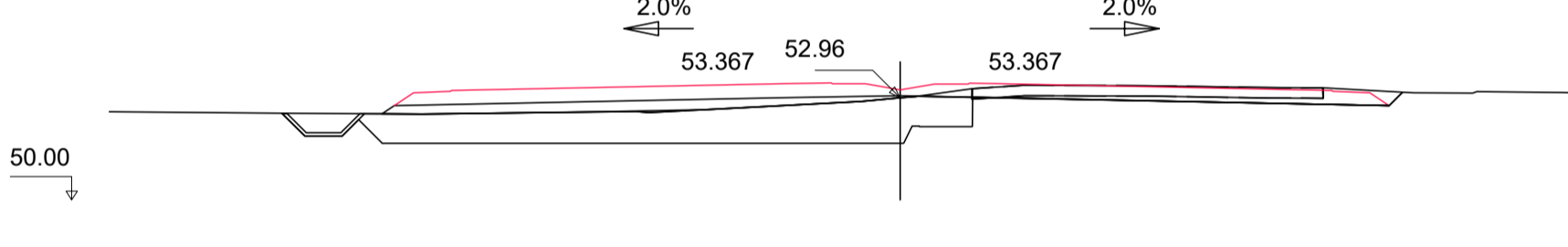

Pk=1+420
 S. FIRME = 11.11 m2. S. REV CUN GUARDA = 0.27 m2.
 S. D TIERRA = 3.44 m2. S. EXCAVA SANEO = 16.99 m2.
 S. SUELO ADEC = 0.06 m2. S. TERRAP SANEO = 16.99 m2.
 S. SUELO S-EST3 = 3.75 m2. S. DEMOLICION = 3.04 m2.

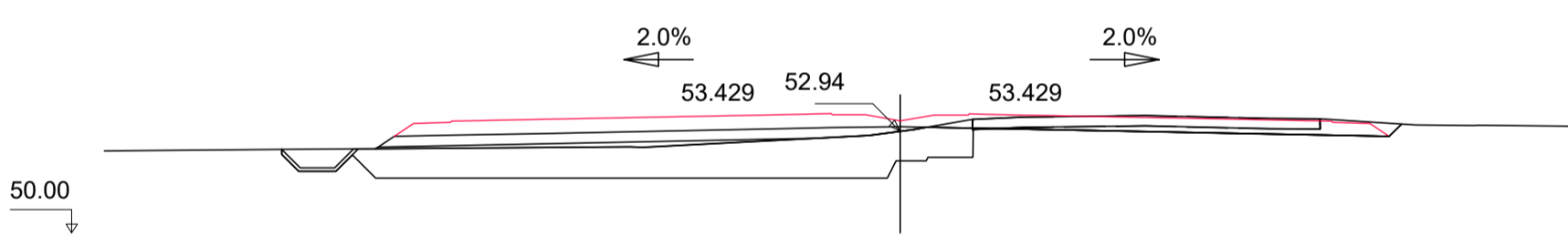

Pk=1+440
 S. FIRME = 11.11 m2. S. REV CUN GUARDA = 0.26 m2.
 S. D TIERRA = 3.40 m2. S. EXCAVA SANEO = 16.99 m2.
 S. SUELO ADEC = 1.14 m2. S. TERRAP SANEO = 17.00 m2.
 S. SUELO S-EST3 = 4.38 m2. S. DEMOLICION = 3.01 m2.

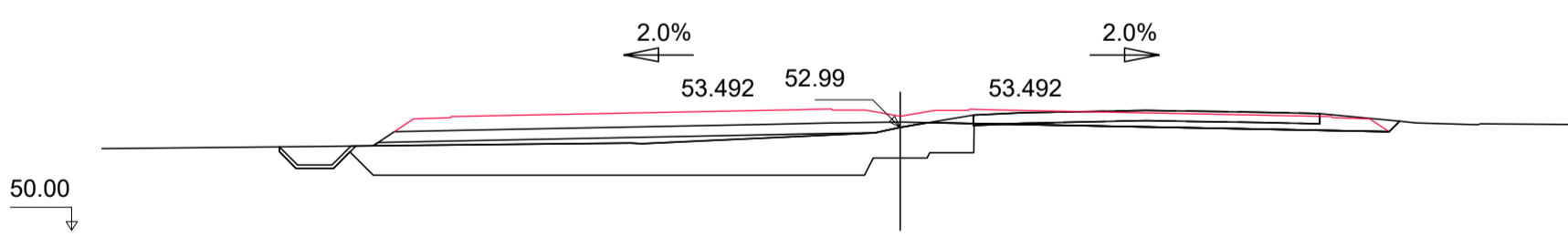

Pk=1+460
 S. FIRME = 11.11 m2. S. REV CUN GUARDA = 0.26 m2.
 S. D TIERRA = 3.47 m2. S. EXCAVA SANEO = 16.88 m2.
 S. SUELO ADEC = 1.68 m2. S. TERRAP SANEO = 16.89 m2.
 S. SUELO S-EST3 = 4.48 m2. S. DEMOLICION = 2.99 m2.

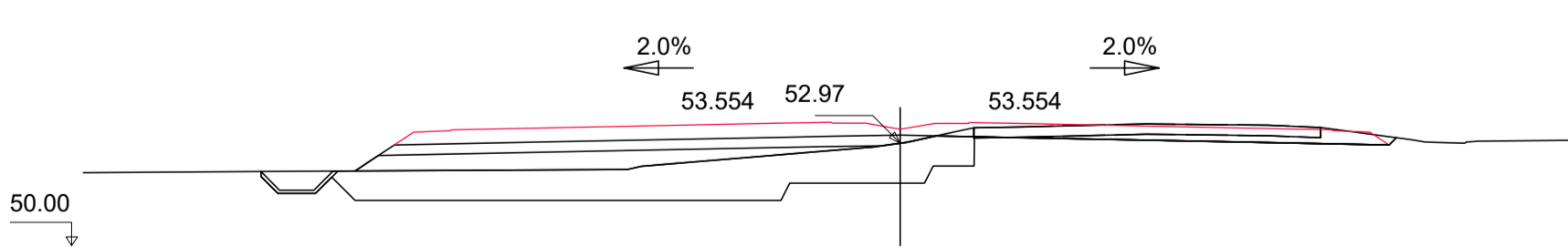

Pk=1+480
 S. FIRME = 11.11 m2. S. REV CUN GUARDA = 0.26 m2.
 S. D TIERRA = 3.23 m2. S. EXCAVA SANEO = 17.86 m2.
 S. SUELO ADEC = 5.59 m2. S. TERRAP SANEO = 17.86 m2.
 S. SUELO S-EST3 = 4.58 m2. S. DEMOLICION = 3.00 m2.

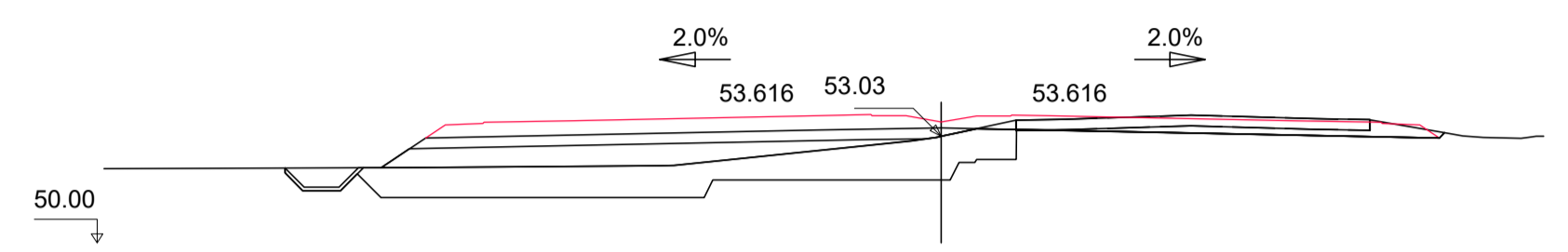

Pk=1+500
 S. FIRME = 11.11 m2. S. REV CUN GUARDA = 0.26 m2.
 S. D TIERRA = 3.27 m2. S. EXCAVA SANEO = 16.28 m2.
 S. SUELO ADEC = 6.89 m2. S. TERRAP SANEO = 16.28 m2.
 S. SUELO S-EST3 = 4.58 m2. S. DEMOLICION = 3.01 m2.

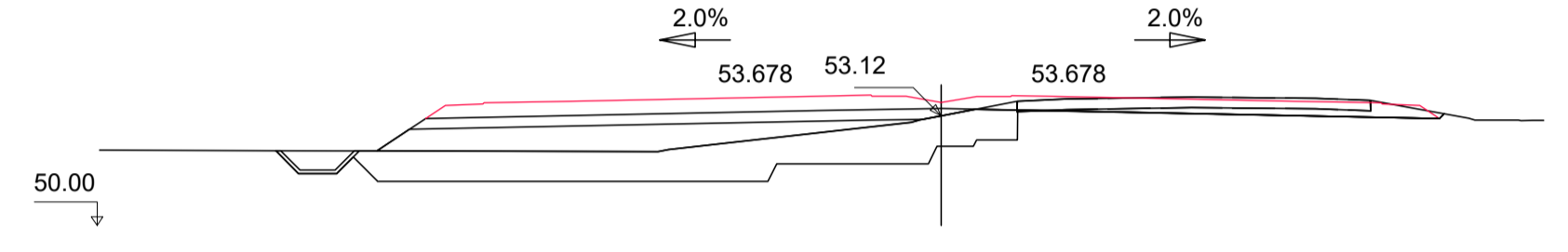

Pk=1+520
 S. FIRME = 11.11 m2. S. REV CUN GUARDA = 0.27 m2.
 S. D TIERRA = 3.26 m2. S. EXCAVA SANEO = 17.30 m2.
 S. SUELO ADEC = 8.20 m2. S. TERRAP SANEO = 17.30 m2.
 S. SUELO S-EST3 = 4.55 m2. S. DEMOLICION = 3.00 m2.

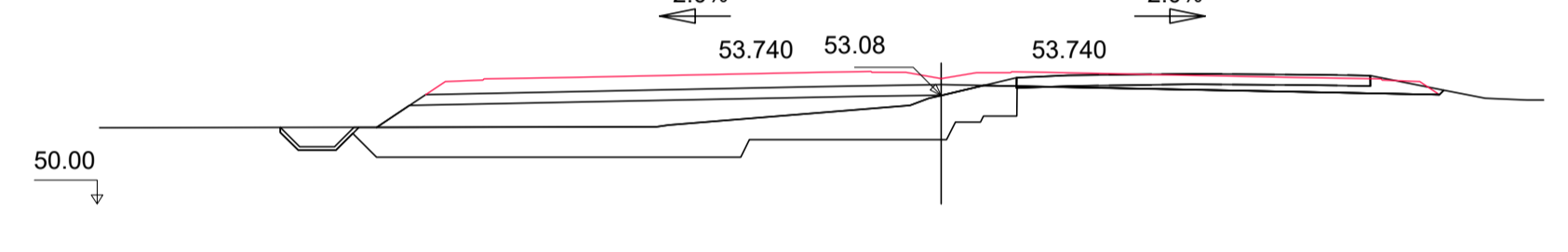

Pk=1+540
 S. FIRME = 11.11 m2. S. REV CUN GUARDA = 0.26 m2.
 S. D TIERRA = 3.16 m2. S. EXCAVA SANEO = 16.34 m2.
 S. SUELO ADEC = 8.82 m2. S. TERRAP SANEO = 16.34 m2.
 S. SUELO S-EST3 = 4.65 m2. S. DEMOLICION = 2.99 m2.

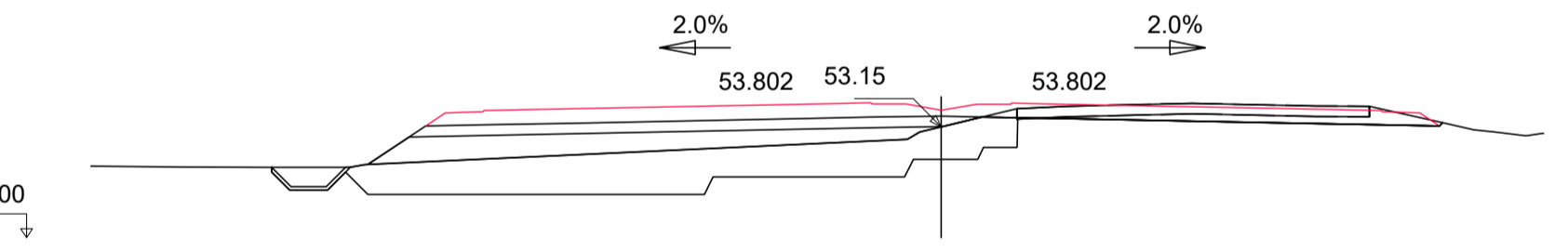

Pk=1+560
 S. FIRME = 11.11 m2. S. REV CUN GUARDA = 0.26 m2.
 S. D TIERRA = 3.41 m2. S. EXCAVA SANEO = 18.82 m2.
 S. SUELO ADEC = 8.21 m2. S. TERRAP SANEO = 18.82 m2.
 S. SUELO S-EST3 = 4.65 m2. S. DEMOLICION = 2.99 m2.

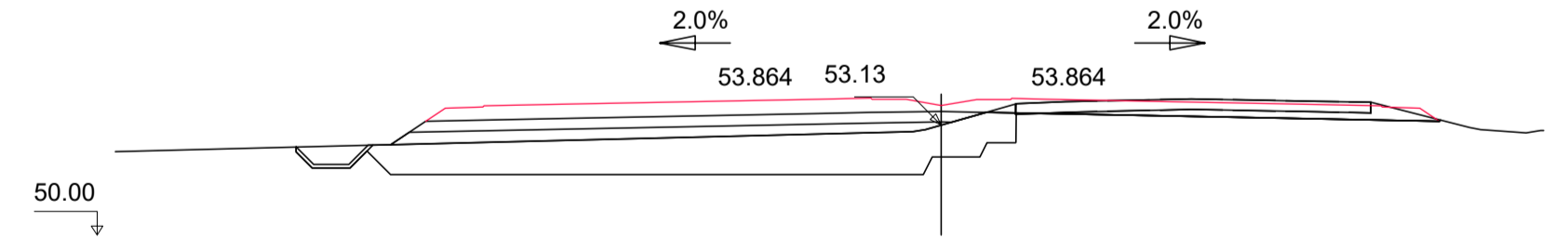

Pk=1+580
 S. FIRME = 11.11 m2. S. REV CUN GUARDA = 0.26 m2.
 S. D TIERRA = 3.17 m2. S. EXCAVA SANEO = 18.63 m2.
 S. SUELO ADEC = 4.64 m2. S. TERRAP SANEO = 18.63 m2.
 S. SUELO S-EST3 = 4.70 m2. S. DEMOLICION = 3.02 m2.

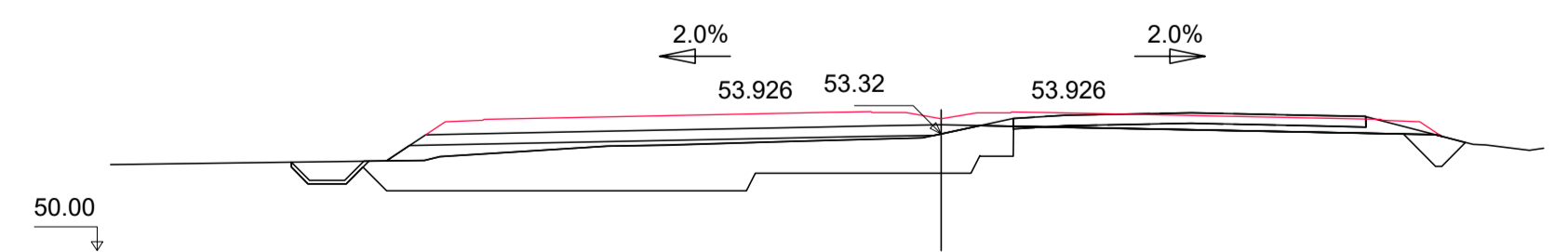

Pk=1+600
 S. FIRME = 11.11 m2. S. REV CUN GUARDA = 0.26 m2.
 S. D TIERRA = 2.98 m2. S. EXCAVA SANEO = 20.44 m2.
 S. SUELO ADEC = 2.48 m2. S. TERRAP SANEO = 20.44 m2.
 S. SUELO S-EST3 = 4.61 m2. S. DEMOLICION = 2.97 m2.

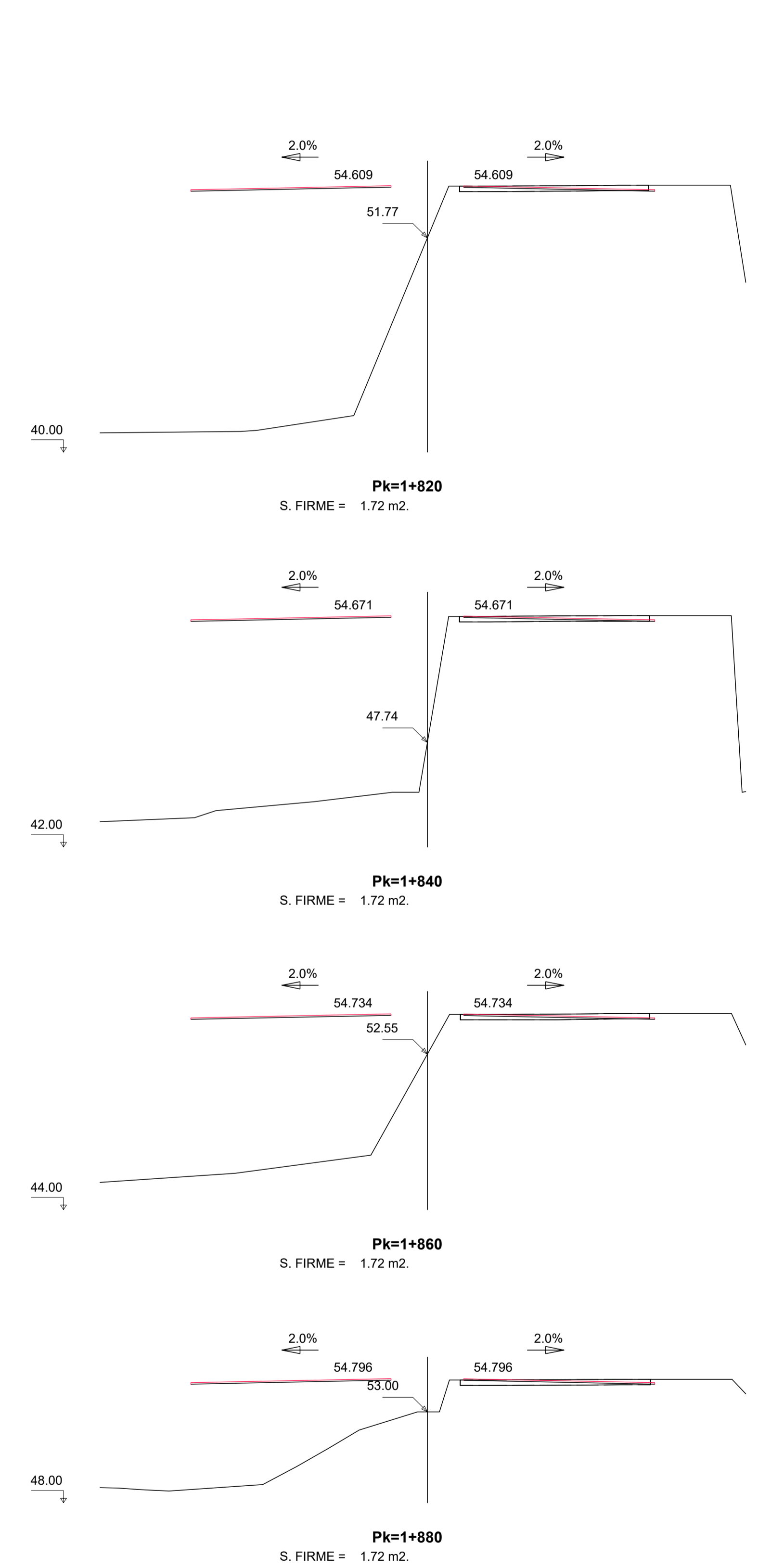
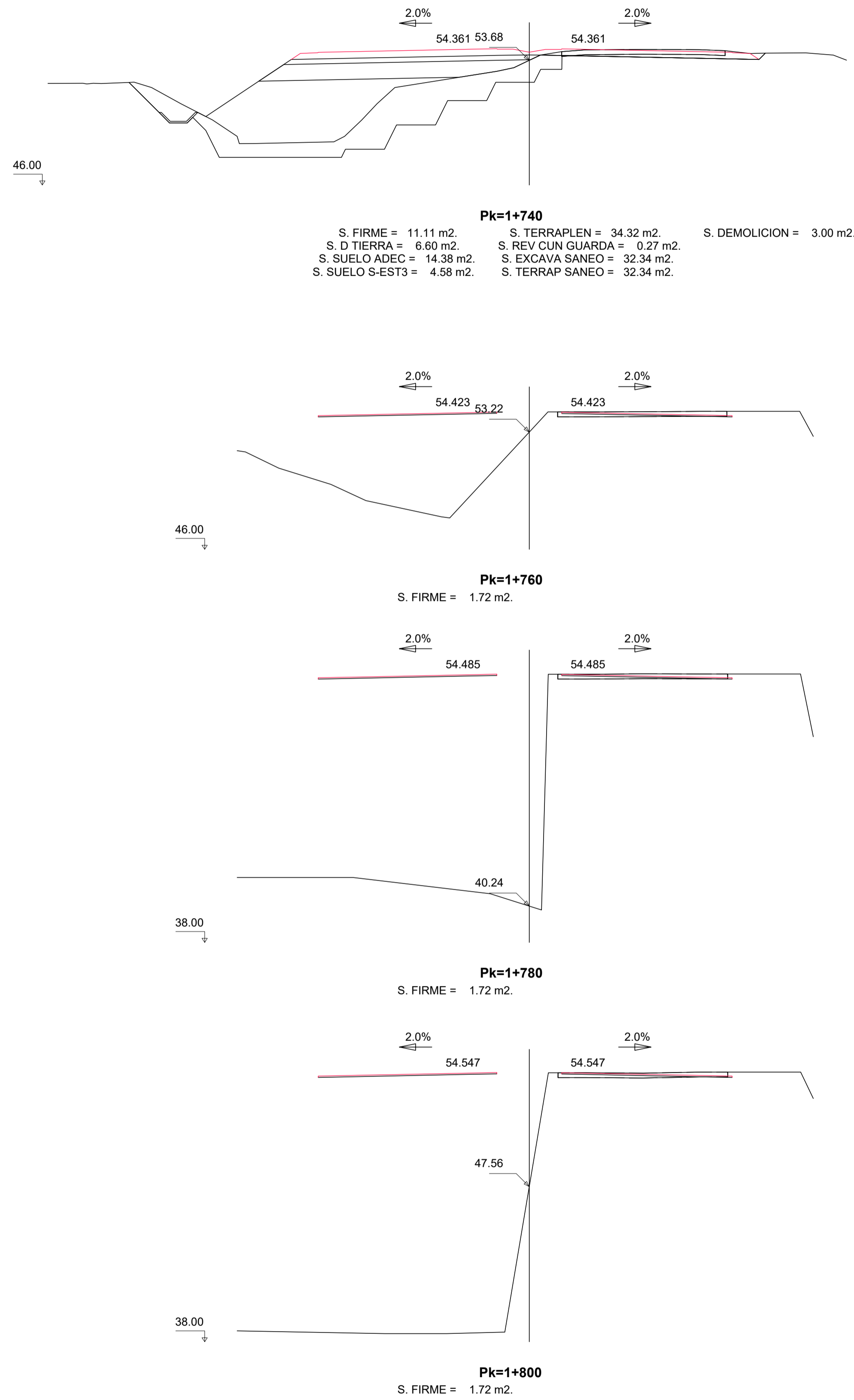
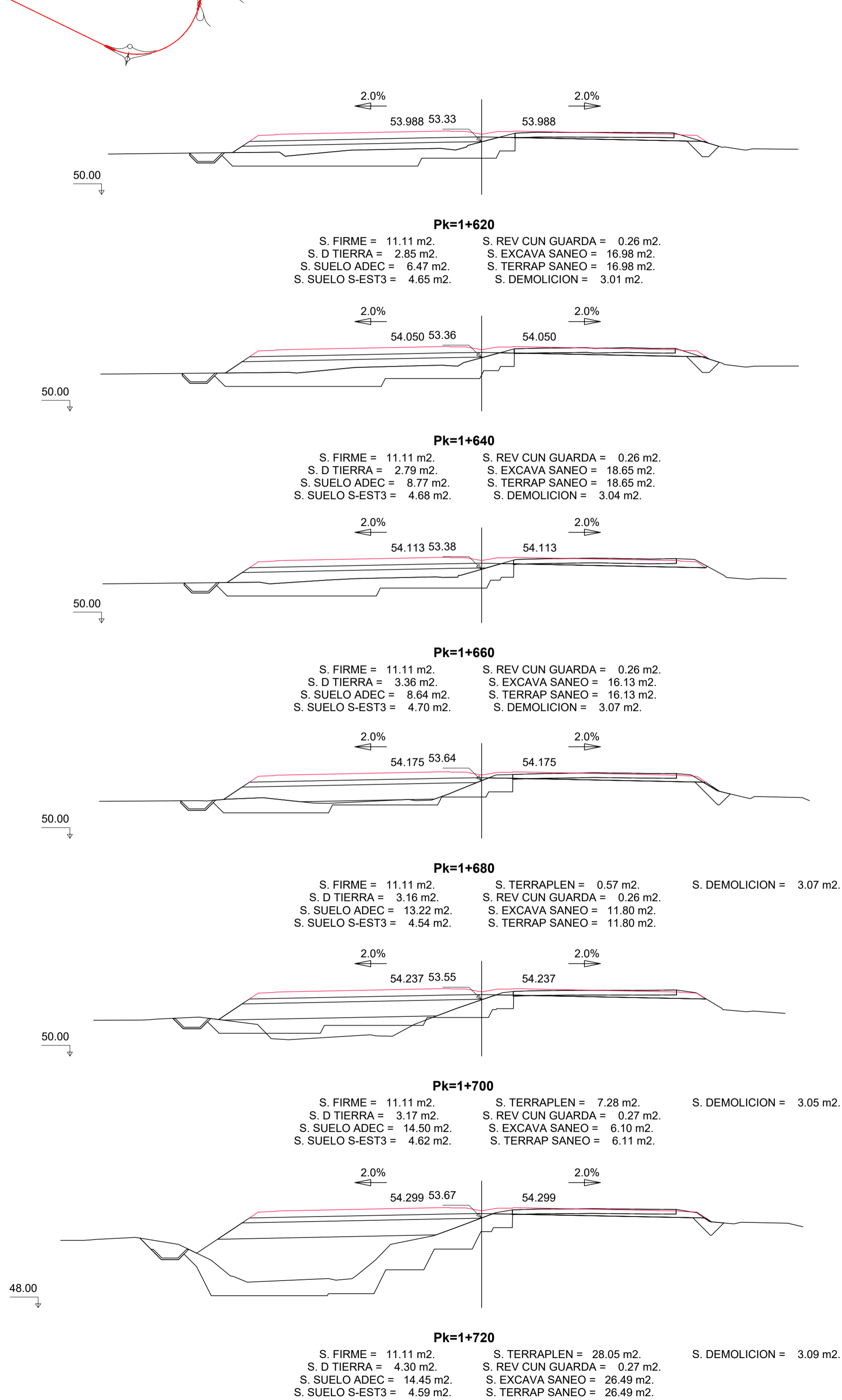
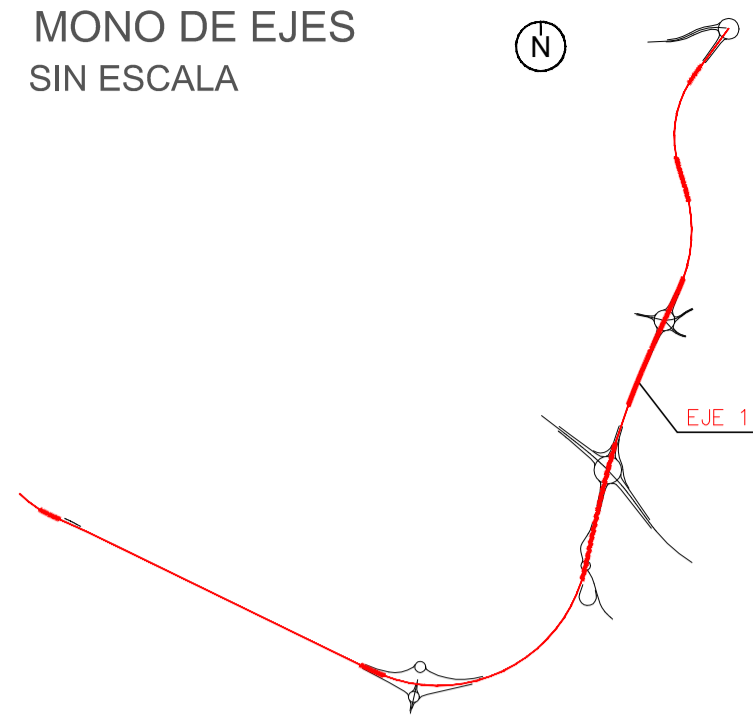

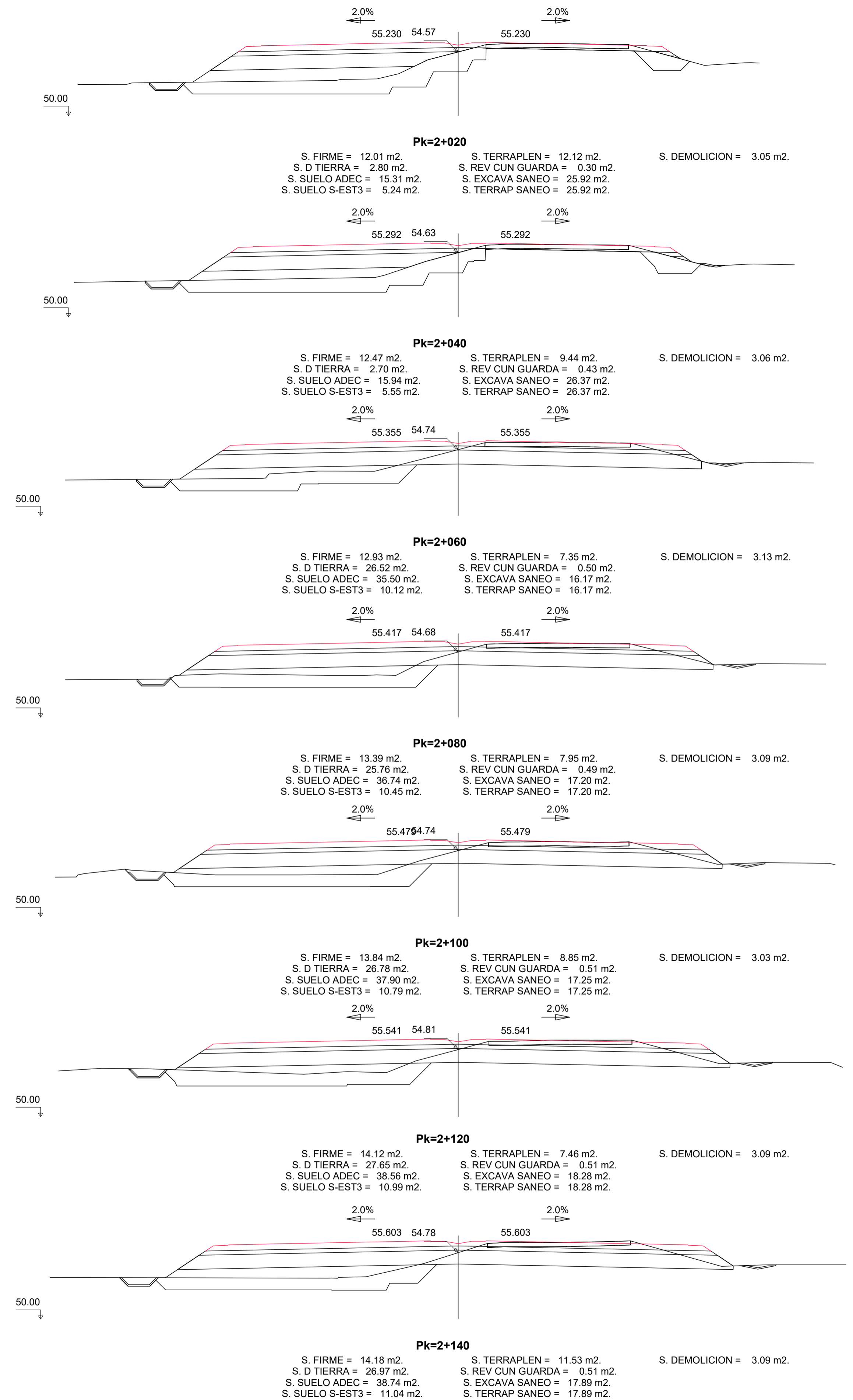
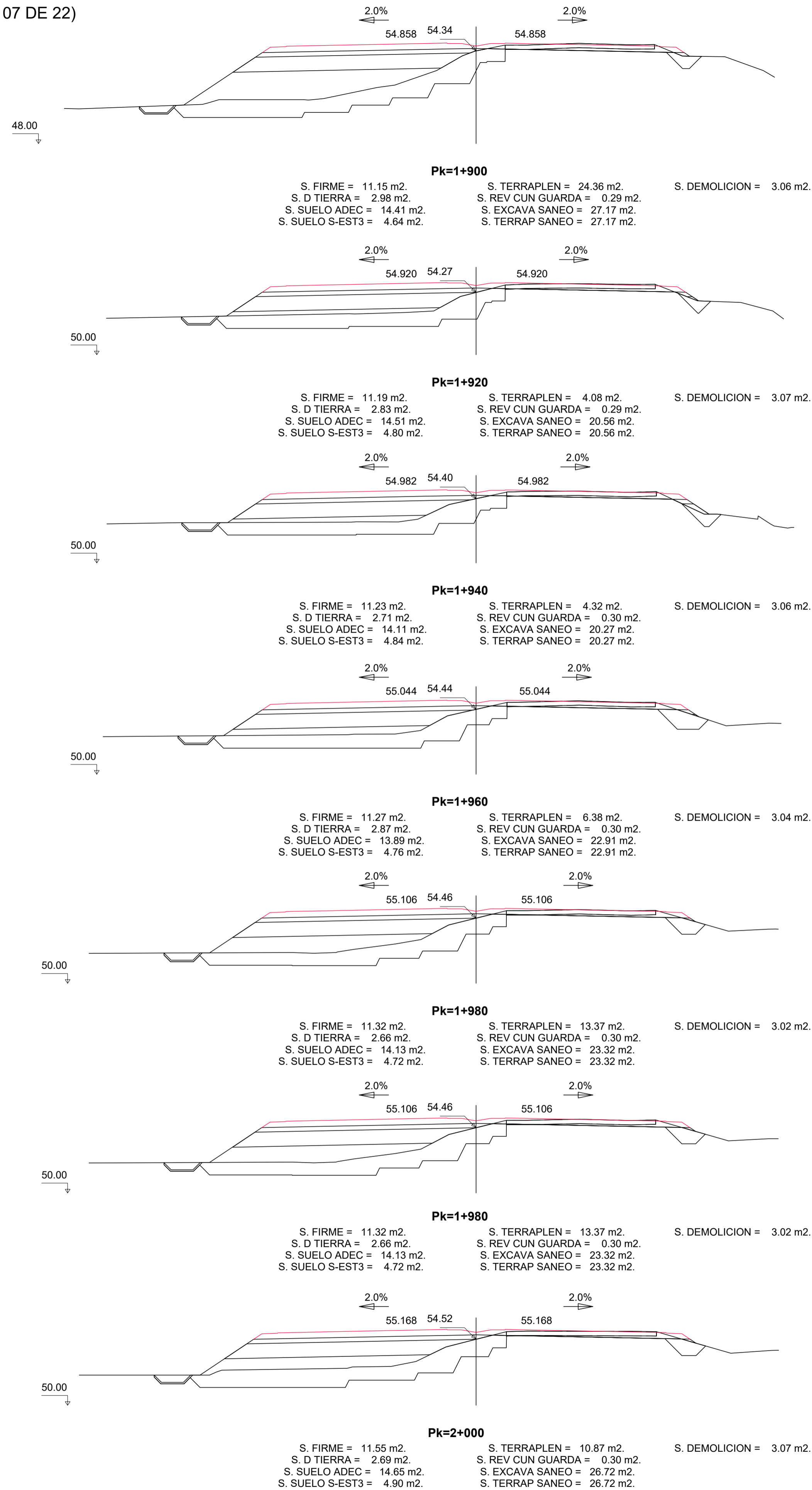
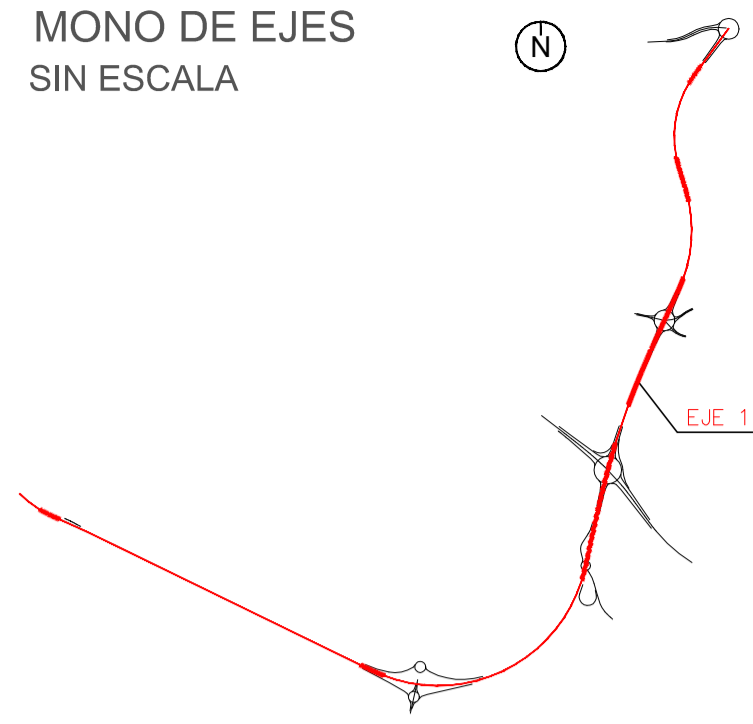

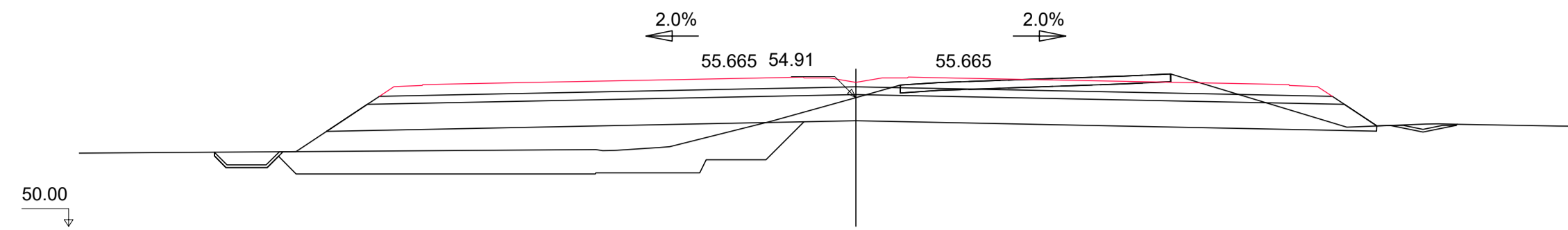
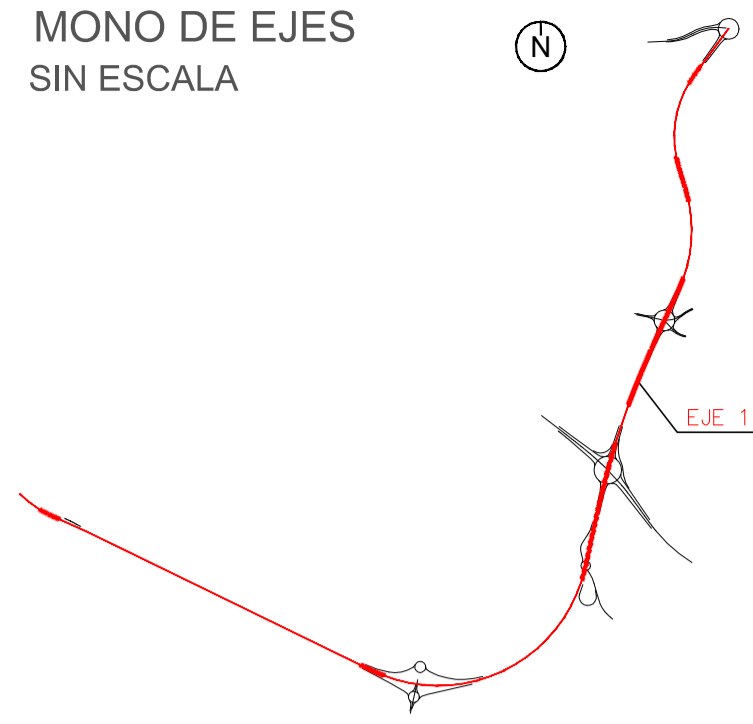

Pk=2+160
 S. FIRME = 14.18 m² S. TERRAPLEN = 13.09 m² S. DEMOLICION = 3.09 m²
 S. D TIERRA = 27.27 m² S. REV CUN GUARDA = 0.50 m²
 S. SUELO ADEC = 38.76 m² S. EXCAVA SANEADO = 18.23 m²
 S. SUELO S-EST3 = 11.04 m² S. TERRAP SANEADO = 18.23 m²

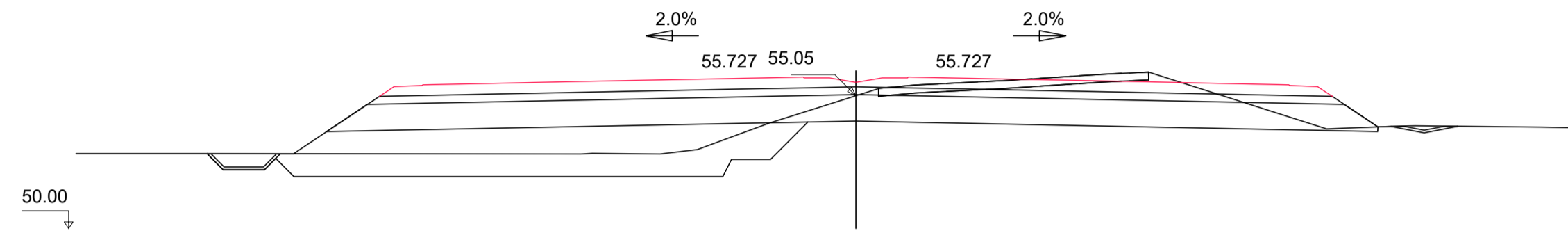

Pk=2+180
 S. FIRME = 14.18 m² S. TERRAPLEN = 15.76 m² S. DEMOLICION = 3.09 m²
 S. D TIERRA = 25.99 m² S. REV CUN GUARDA = 0.51 m²
 S. SUELO ADEC = 38.77 m² S. EXCAVA SANEADO = 17.85 m²
 S. SUELO S-EST3 = 11.04 m² S. TERRAP SANEADO = 17.85 m²

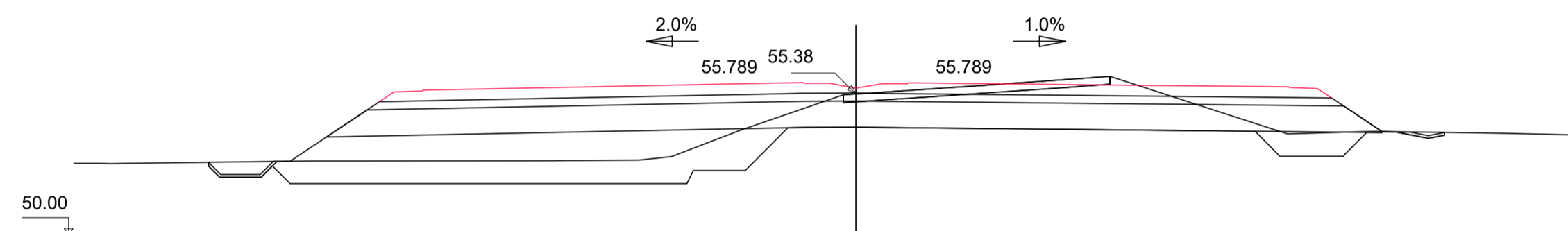

Pk=2+200
 S. FIRME = 14.21 m² S. TERRAPLEN = 15.69 m² S. DEMOLICION = 3.05 m²
 S. D TIERRA = 23.91 m² S. REV CUN GUARDA = 0.46 m²
 S. SUELO ADEC = 38.75 m² S. EXCAVA SANEADO = 20.73 m²
 S. SUELO S-EST3 = 11.03 m² S. TERRAP SANEADO = 20.73 m²

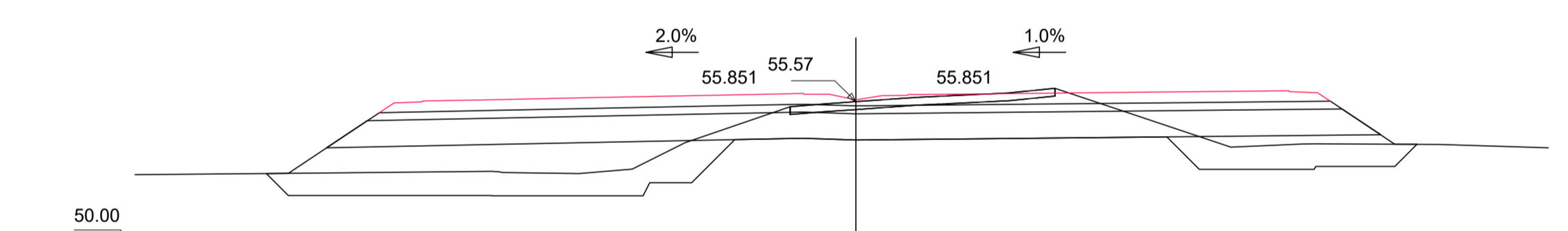

Pk=2+220
 S. FIRME = 14.27 m² S. TERRAPLEN = 16.37 m²
 S. D TIERRA = 20.39 m² S. EXCAVA SANEADO = 24.01 m²
 S. SUELO ADEC = 38.66 m² S. TERRAP SANEADO = 24.01 m²
 S. SUELO S-EST3 = 11.01 m² S. DEMOLICION = 3.03 m²

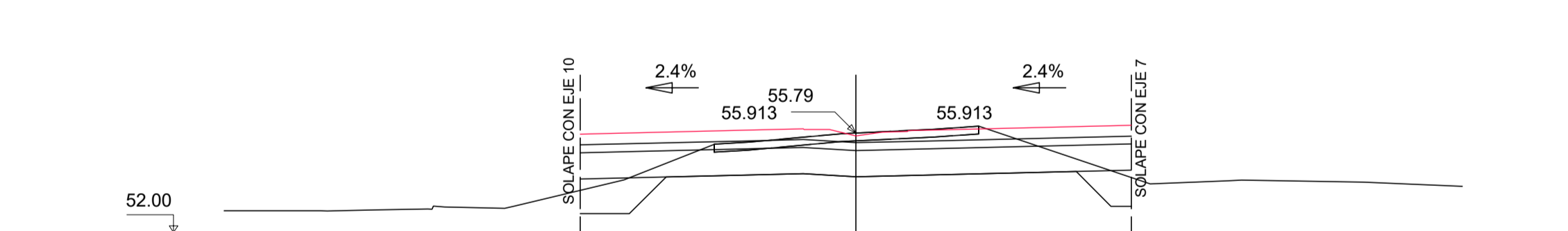

Pk=2+240
 S. FIRME = 8.43 m² S. TERRAPLEN = 0.54 m²
 S. D TIERRA = 19.05 m² S. EXCAVA SANEADO = 4.89 m²
 S. SUELO ADEC = 21.00 m² S. TERRAP SANEADO = 4.89 m²
 S. SUELO S-EST3 = 6.30 m² S. DEMOLICION = 3.03 m²

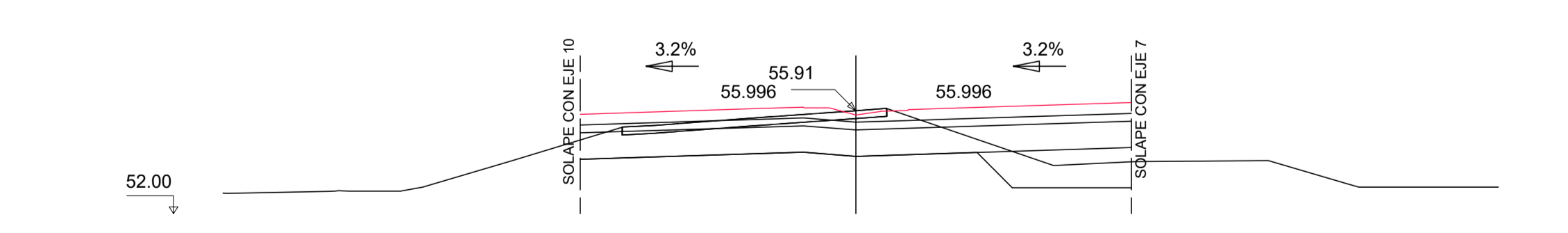

Pk=2+260
 S. FIRME = 8.46 m² S. TERRAPLEN = 2.13 m²
 S. D TIERRA = 16.94 m² S. EXCAVA SANEADO = 5.42 m²
 S. SUELO ADEC = 21.00 m² S. TERRAP SANEADO = 5.42 m²
 S. SUELO S-EST3 = 6.30 m² S. DEMOLICION = 3.02 m²

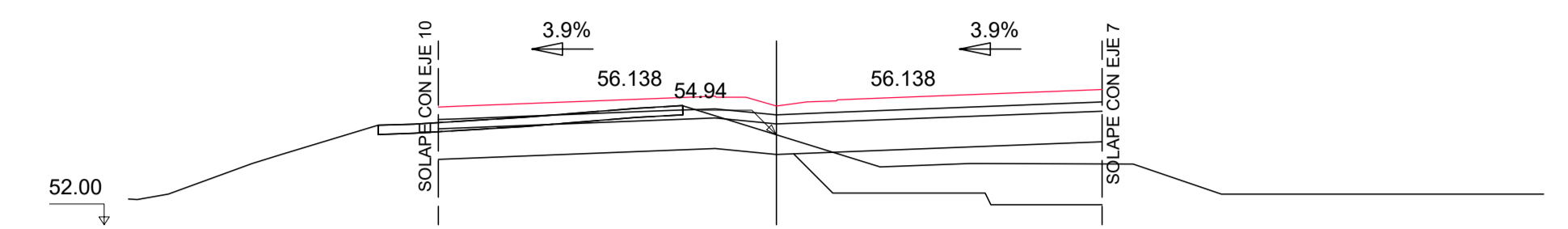

Pk=2+280
 S. FIRME = 8.79 m² S. TERRAPLEN = 4.75 m²
 S. D TIERRA = 11.81 m² S. EXCAVA SANEADO = 10.78 m²
 S. SUELO ADEC = 21.72 m² S. TERRAP SANEADO = 10.78 m²
 S. SUELO S-EST3 = 6.52 m² S. DEMOLICION = 2.40 m²

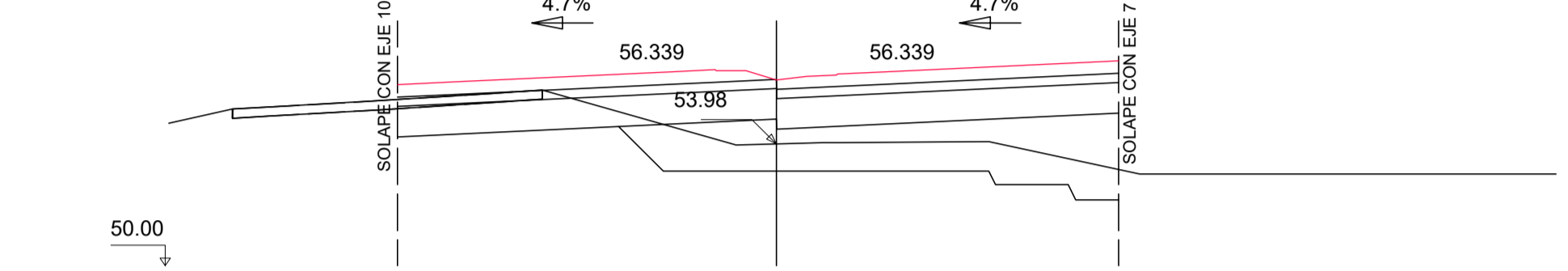

Pk=2+300
 S. FIRME = 9.27 m² S. TERRAPLEN = 11.62 m²
 S. D TIERRA = 7.17 m² S. EXCAVA SANEADO = 16.35 m²
 S. SUELO ADEC = 23.60 m² S. TERRAP SANEADO = 16.35 m²
 S. SUELO S-EST3 = 7.08 m² S. DEMOLICION = 1.42 m²

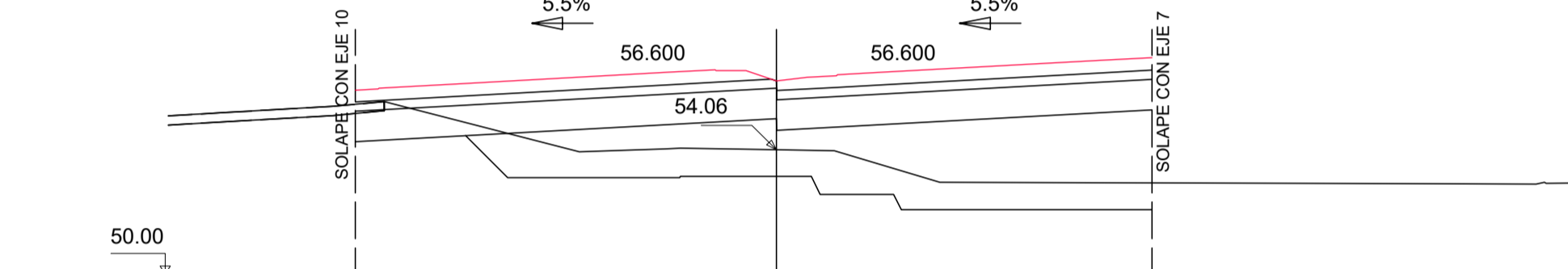

Pk=2+320
 S. FIRME = 10.25 m² S. TERRAPLEN = 27.58 m²
 S. D TIERRA = 3.42 m² S. EXCAVA SANEADO = 21.50 m²
 S. SUELO ADEC = 26.08 m² S. TERRAP SANEADO = 21.50 m²
 S. SUELO S-EST3 = 7.82 m² S. DEMOLICION = 0.29 m²

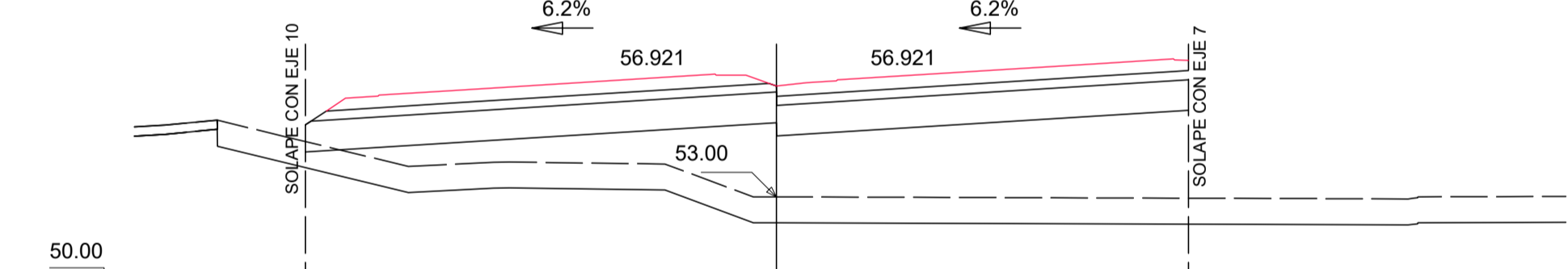

Pk=2+340
 S. FIRME = 10.94 m² S. VEGETAL = 24.57 m²
 S. SUELO ADEC = 28.90 m²
 S. SUELO S-EST3 = 8.53 m²
 S. TERRAPLEN = 72.02 m²

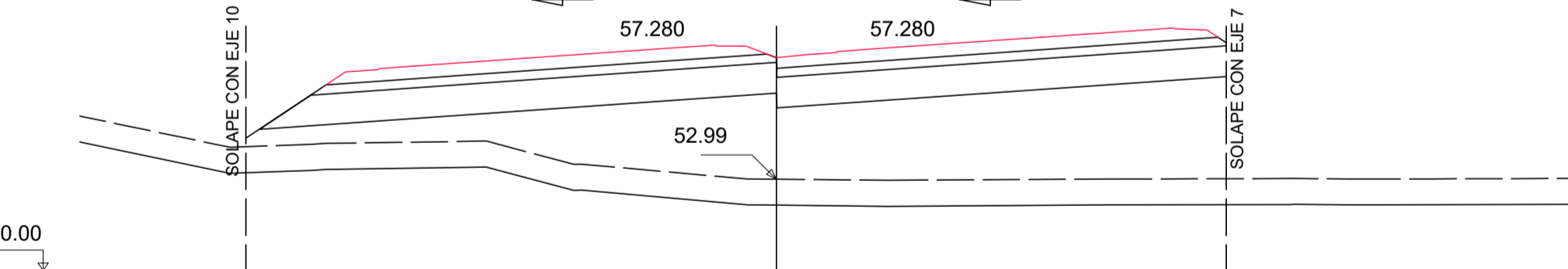

Pk=2+360
 S. FIRME = 11.16 m² S. VEGETAL = 27.27 m²
 S. SUELO ADEC = 30.80 m²
 S. SUELO S-EST3 = 8.86 m²
 S. TERRAPLEN = 94.49 m²

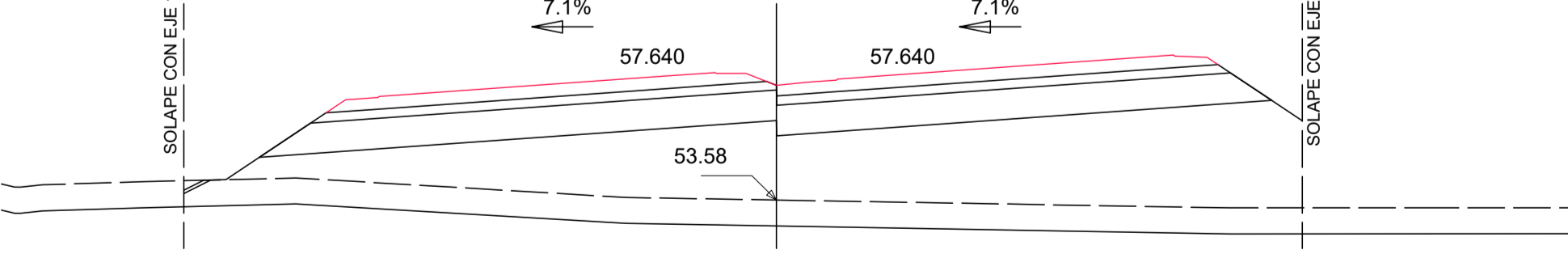

Pk=2+380
 S. FIRME = 11.16 m² S. REV CUN GUARDA = 0.09 m²
 S. SUELO ADEC = 31.82 m² S. VEGETAL = 31.12 m²
 S. SUELO S-EST3 = 8.87 m²
 S. TERRAPLEN = 108.58 m²

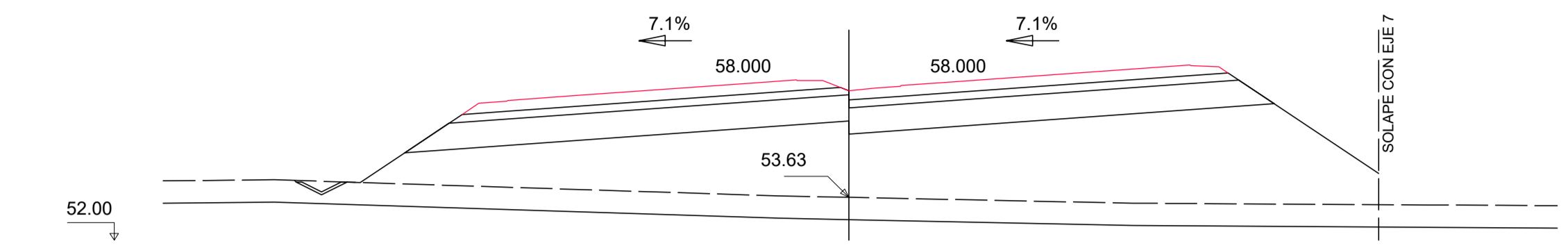
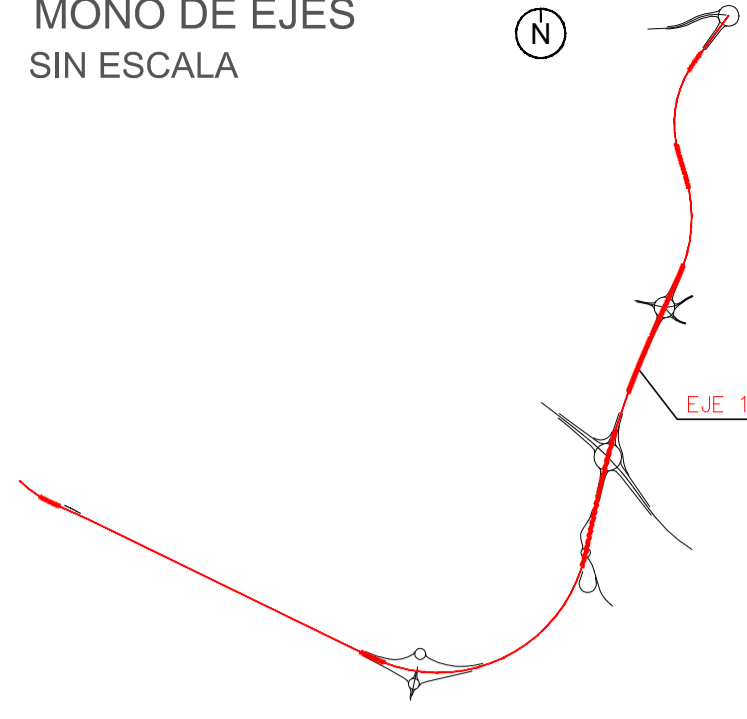

Pk=2+400
 S. FIRME = 11.16 m2. S. REV CUN GUARDA = 0.19 m2.
 S. SUELO ADEC = 31.62 m2. S. VEGETAL = 35.13 m2.
 S. SUELO S-EST3 = 8.87 m2.
 S. TERRAPLEN = 131.39 m2.

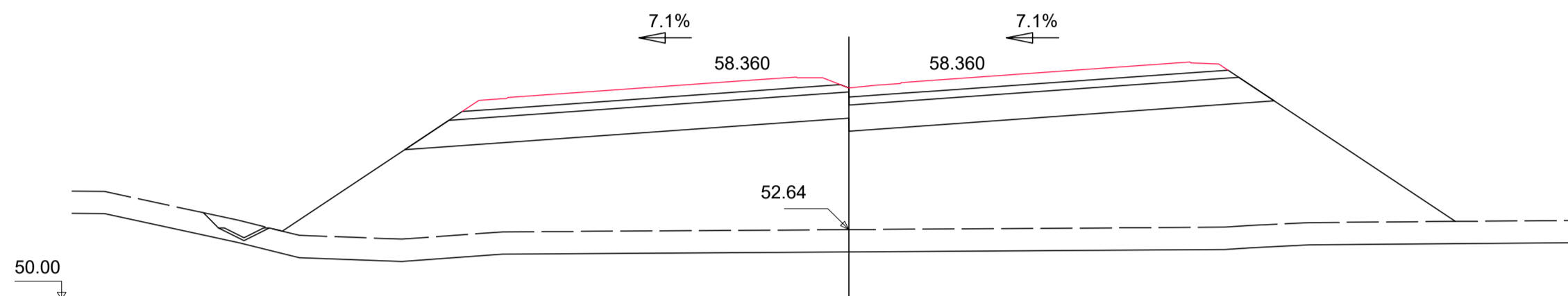

Pk=2+420
 S. FIRME = 11.16 m2. S. REV CUN GUARDA = 0.19 m2.
 S. SUELO ADEC = 31.62 m2. S. VEGETAL = 40.56 m2.
 S. SUELO S-EST3 = 8.87 m2.
 S. TERRAPLEN = 196.32 m2.

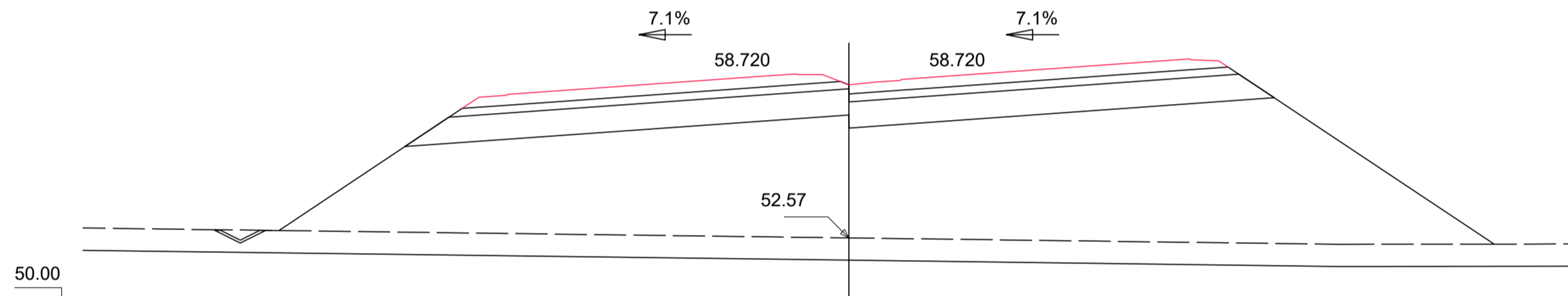

Pk=2+440
 S. FIRME = 11.16 m2. S. REV CUN GUARDA = 0.19 m2.
 S. SUELO ADEC = 31.62 m2. S. VEGETAL = 41.46 m2.
 S. SUELO S-EST3 = 8.87 m2.
 S. TERRAPLEN = 218.56 m2.

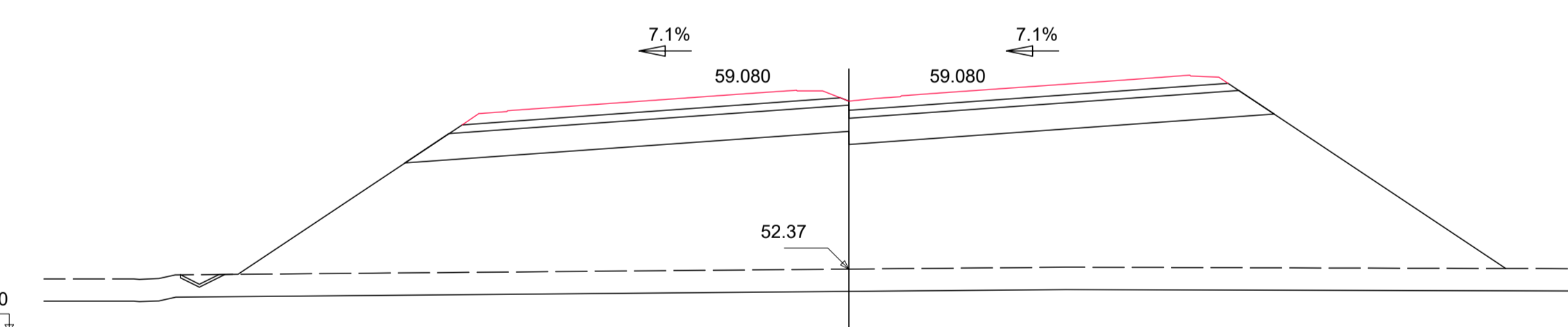

Pk=2+460
 S. FIRME = 11.16 m2. S. REV CUN GUARDA = 0.18 m2.
 S. SUELO ADEC = 31.62 m2. S. VEGETAL = 42.93 m2.
 S. SUELO S-EST3 = 8.87 m2.
 S. TERRAPLEN = 246.99 m2.

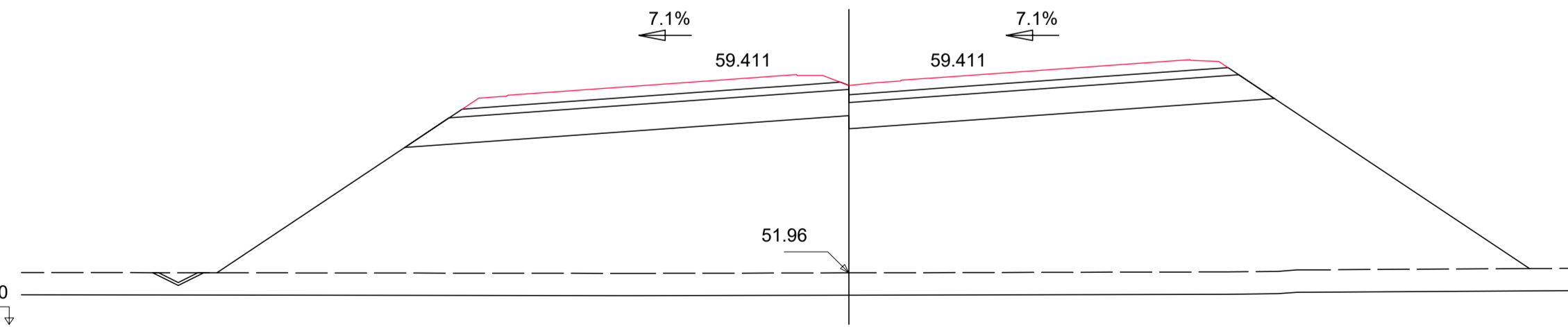

Pk=2+480
 S. FIRME = 11.16 m2. S. REV CUN GUARDA = 0.19 m2.
 S. SUELO ADEC = 31.62 m2. S. VEGETAL = 44.60 m2.
 S. SUELO S-EST3 = 8.87 m2.
 S. TERRAPLEN = 282.43 m2.

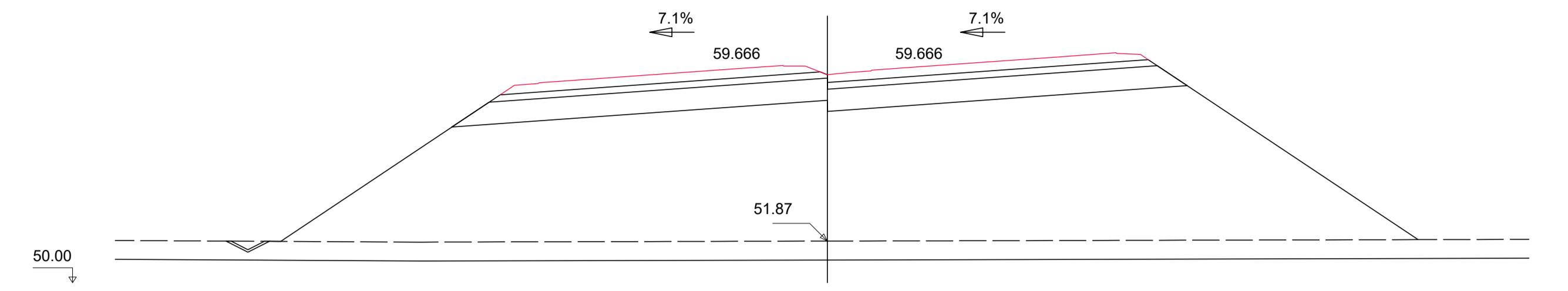

Pk=2+500
 S. FIRME = 11.16 m2. S. REV CUN GUARDA = 0.19 m2.
 S. SUELO ADEC = 31.62 m2. S. VEGETAL = 45.63 m2.
 S. SUELO S-EST3 = 8.87 m2.
 S. TERRAPLEN = 302.24 m2.

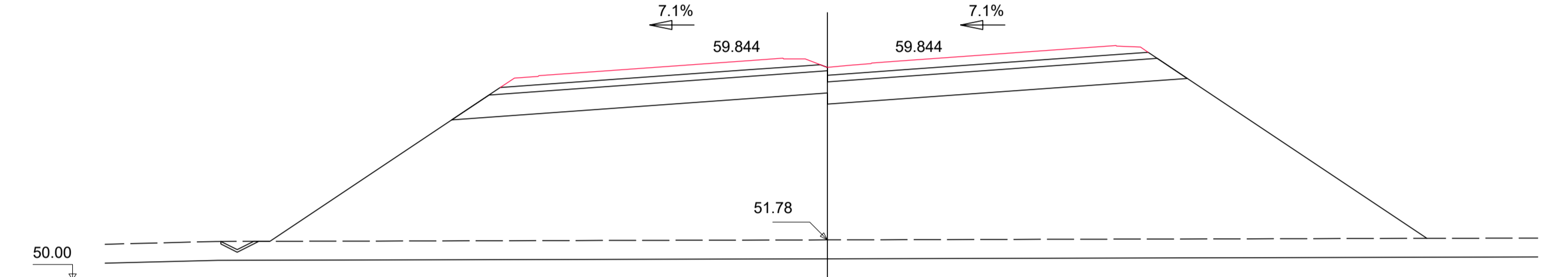

Pk=2+520
 S. FIRME = 11.16 m2. S. REV CUN GUARDA = 0.18 m2.
 S. SUELO ADEC = 31.62 m2. S. VEGETAL = 46.17 m2.
 S. SUELO S-EST3 = 8.87 m2.
 S. TERRAPLEN = 316.81 m2.

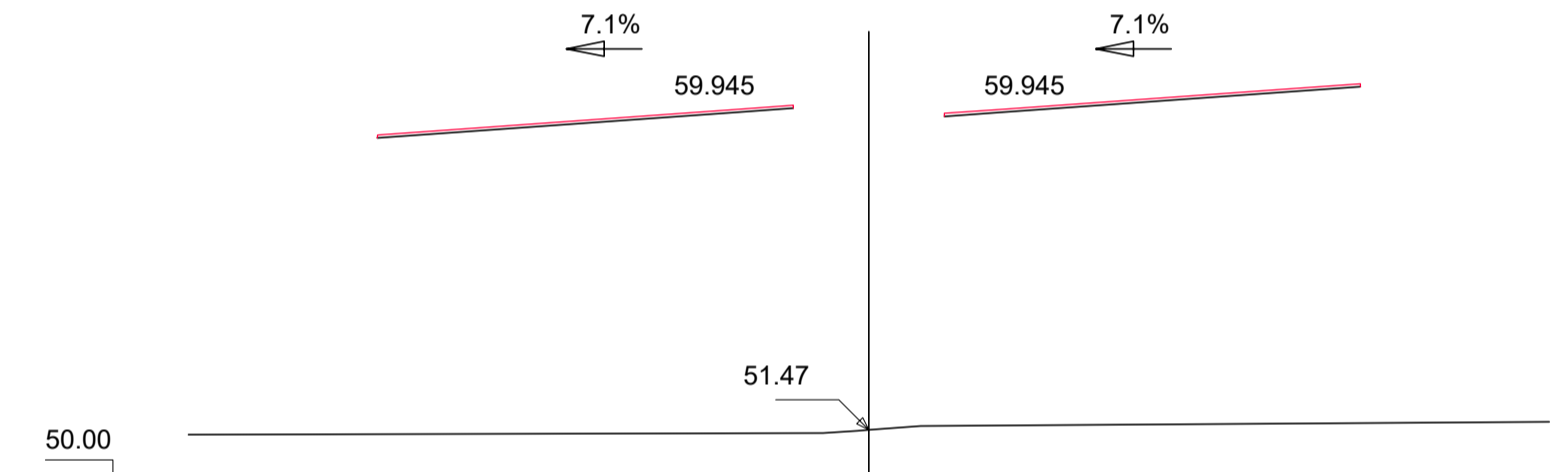

Pk=2+540
 S. FIRME = 1.76 m2.

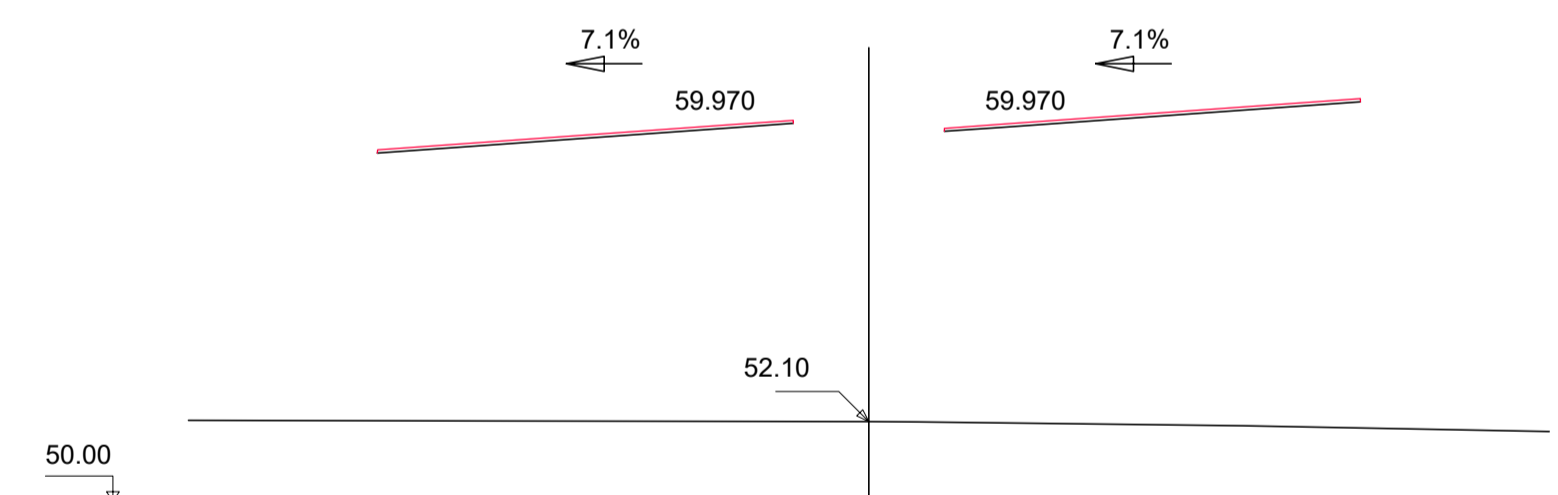

Pk=2+560
 S. FIRME = 1.76 m2.

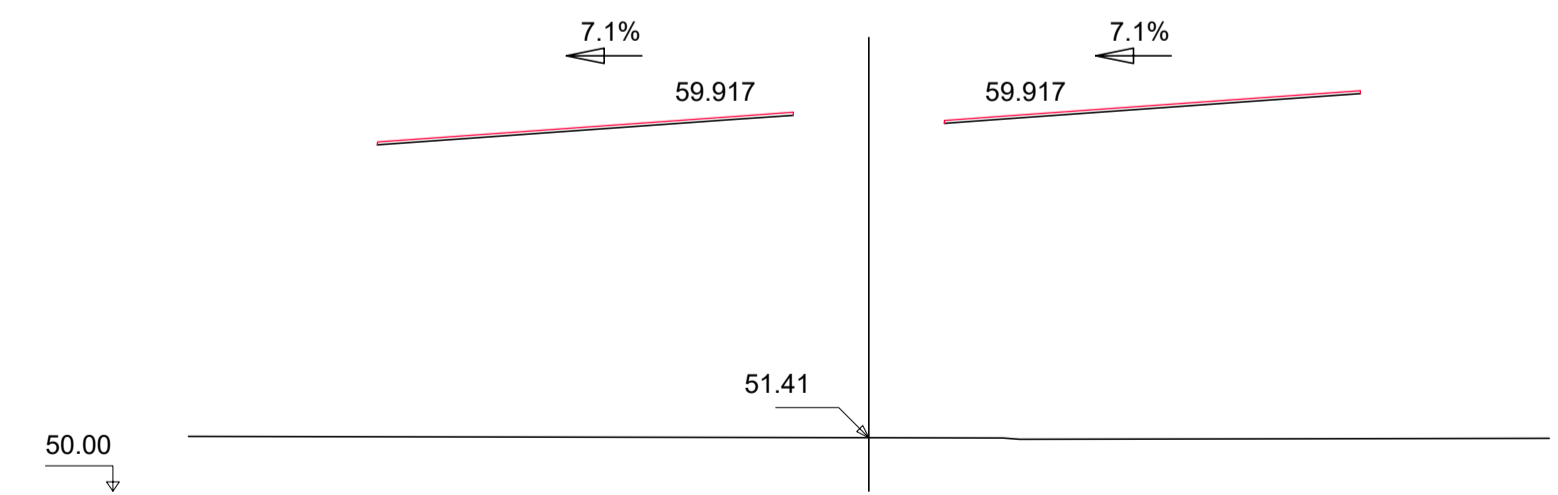

Pk=2+580
 S. FIRME = 1.76 m2.

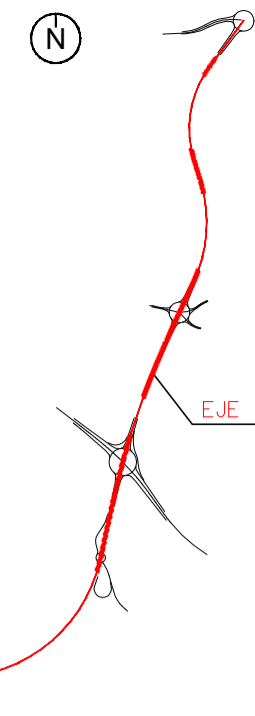

EJE 1 (HOJA 10 DE 22)

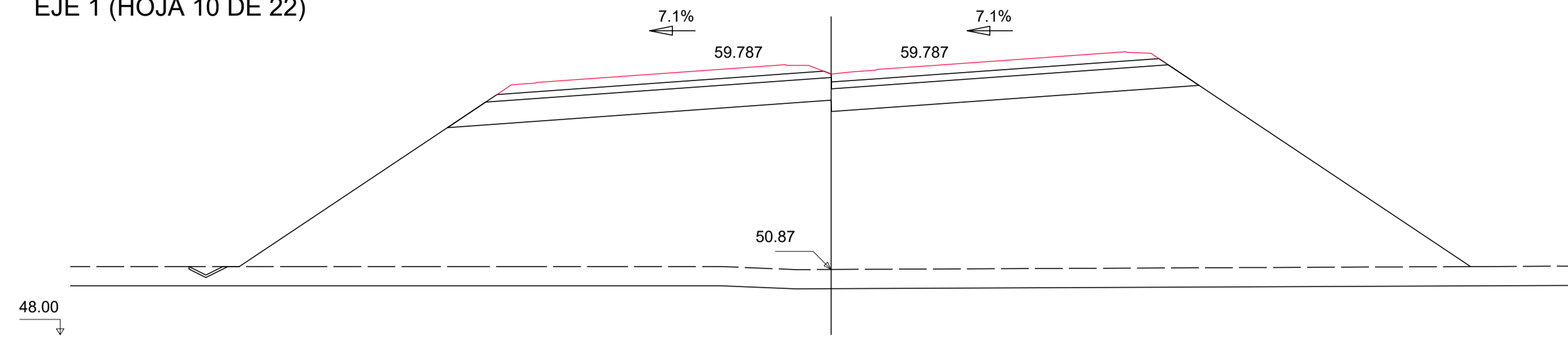

Pk=2+600
 S. FIRME = 11.16 m2 S. REV CUN GUARDA = 0.18 m2.
 S. SUELO ADEC = 31.62 m2 S. VEGETAL = 48.04 m2.
 S. SUELO S-EST3 = 8.87 m2
 S. TERRAPLEN = 359.70 m2.

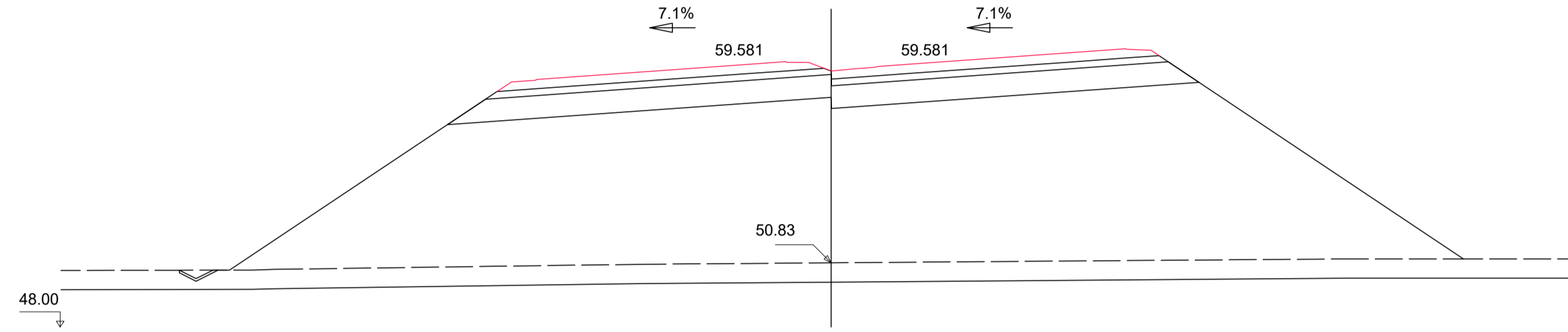

Pk=2+620
 S. FIRME = 11.16 m2 S. REV CUN GUARDA = 0.18 m2.
 S. SUELO ADEC = 31.62 m2 S. VEGETAL = 48.13 m2.
 S. SUELO S-EST3 = 8.87 m2
 S. TERRAPLEN = 356.44 m2.

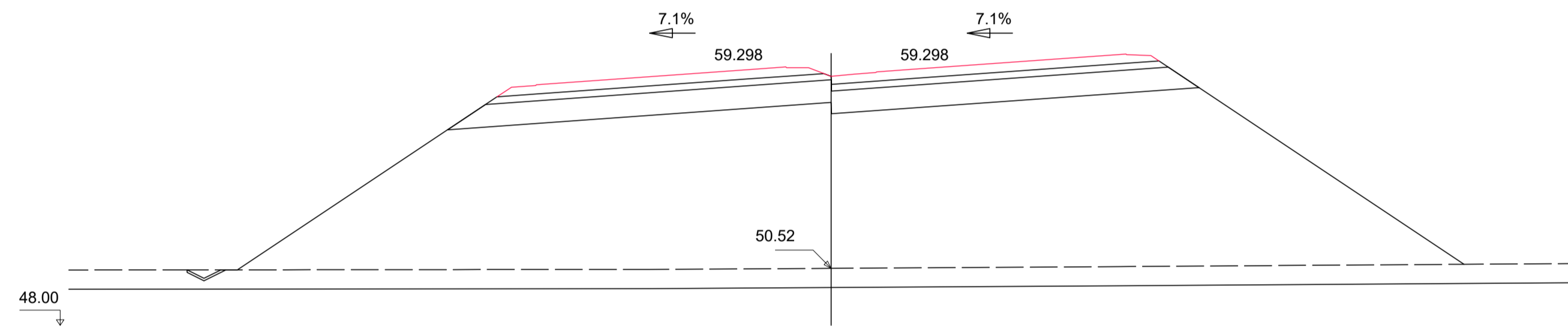

Pk=2+640
 S. FIRME = 11.16 m2 S. REV CUN GUARDA = 0.18 m2.
 S. SUELO ADEC = 31.62 m2 S. VEGETAL = 47.87 m2.
 S. SUELO S-EST3 = 8.87 m2
 S. TERRAPLEN = 355.50 m2.

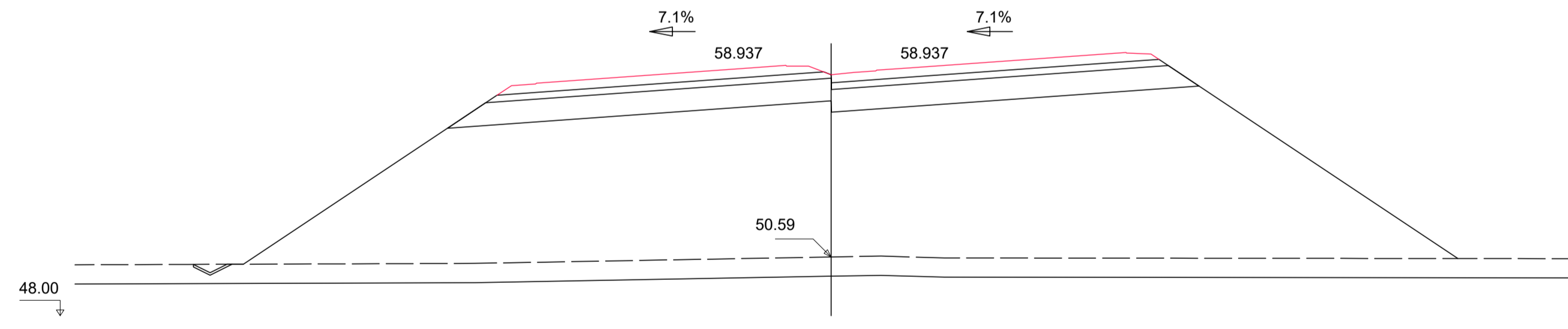

Pk=2+660
 S. FIRME = 11.16 m2 S. REV CUN GUARDA = 0.18 m2.
 S. SUELO ADEC = 31.62 m2 S. VEGETAL = 47.40 m2.
 S. SUELO S-EST3 = 8.87 m2
 S. TERRAPLEN = 339.71 m2.

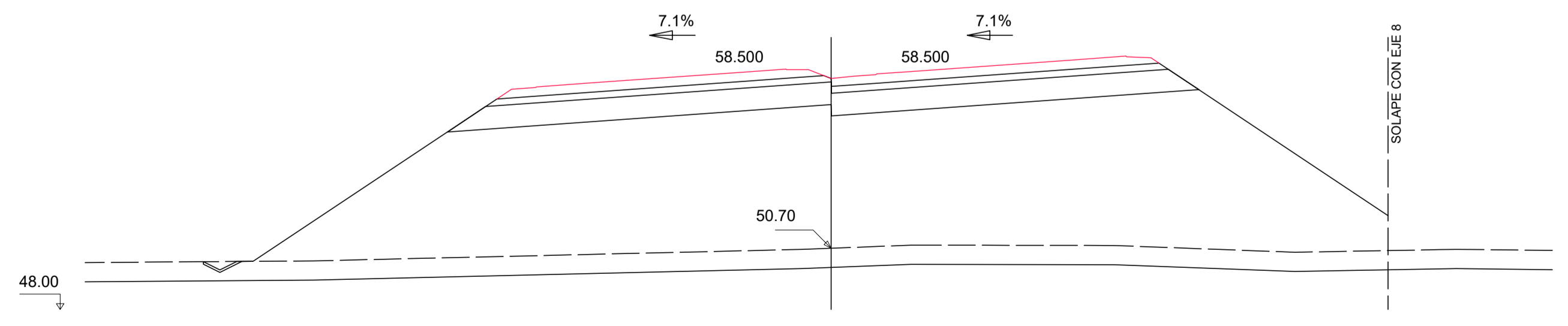

Pk=2+680
 S. FIRME = 11.16 m2 S. REV CUN GUARDA = 0.18 m2.
 S. SUELO ADEC = 31.62 m2 S. VEGETAL = 44.40 m2.
 S. SUELO S-EST3 = 8.87 m2
 S. TERRAPLEN = 307.37 m2.

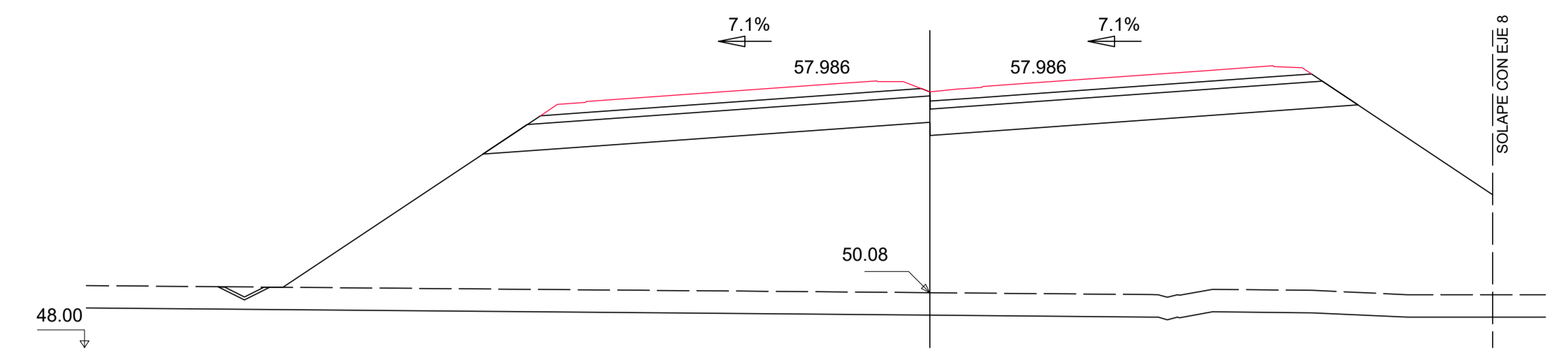

Pk=2+700
 S. FIRME = 11.16 m2 S. REV CUN GUARDA = 0.19 m2.
 S. SUELO ADEC = 31.62 m2 S. VEGETAL = 41.01 m2.
 S. SUELO S-EST3 = 8.87 m2
 S. TERRAPLEN = 291.17 m2.

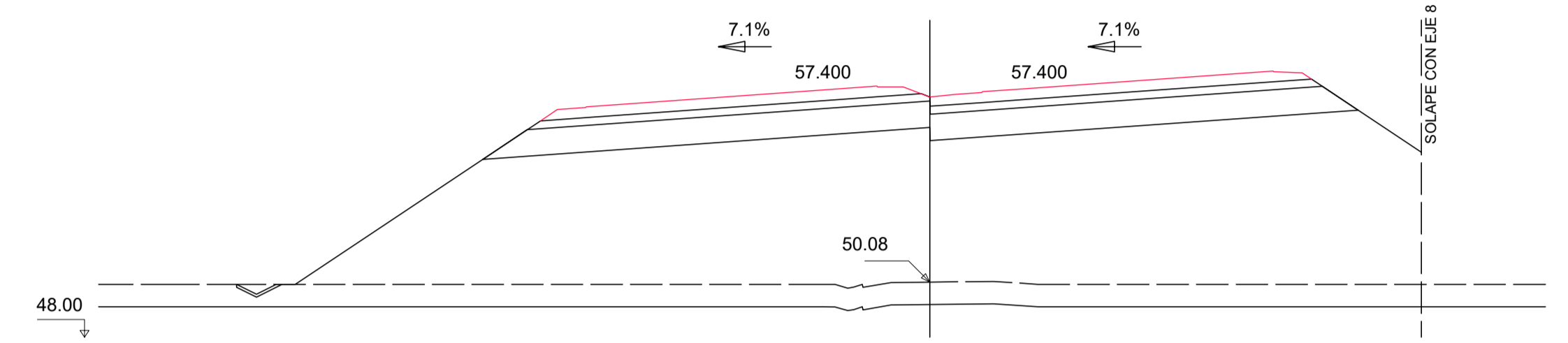

Pk=2+720
 S. FIRME = 11.16 m2 S. REV CUN GUARDA = 0.18 m2.
 S. SUELO ADEC = 31.62 m2 S. VEGETAL = 38.12 m2.
 S. SUELO S-EST3 = 8.87 m2
 S. TERRAPLEN = 255.94 m2.

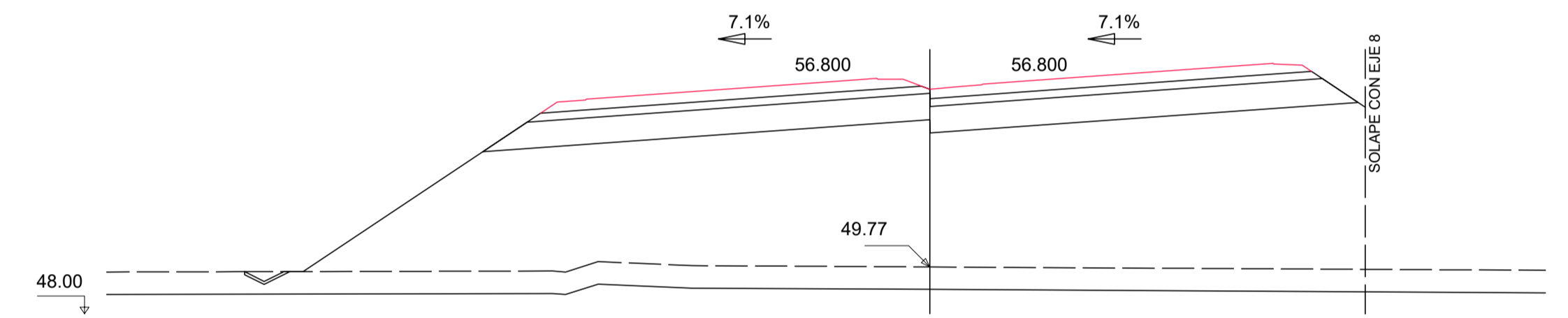

Pk=2+740
 S. FIRME = 11.16 m2 S. REV CUN GUARDA = 0.18 m2.
 S. SUELO ADEC = 31.62 m2 S. VEGETAL = 36.06 m2.
 S. SUELO S-EST3 = 8.87 m2
 S. TERRAPLEN = 228.75 m2.

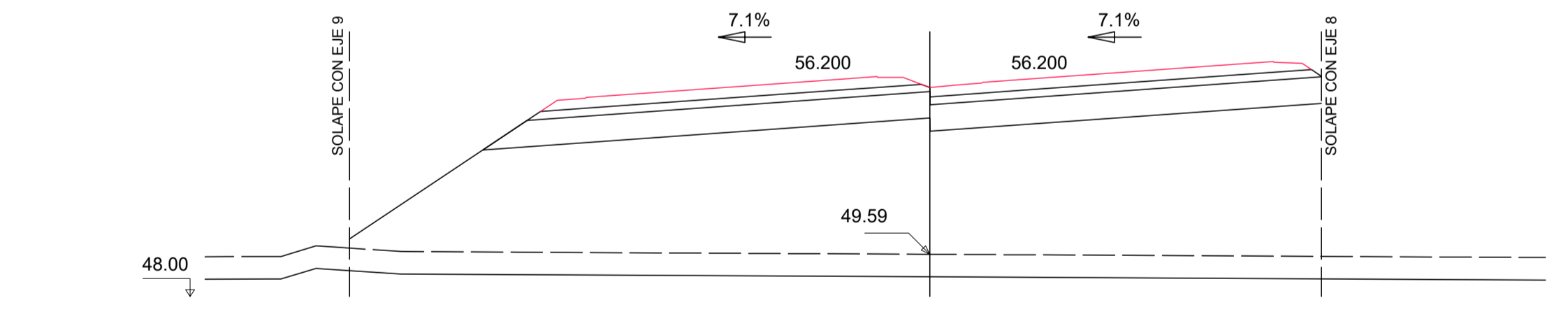

Pk=2+760
 S. FIRME = 11.16 m2 S. VEGETAL = 31.28 m2.
 S. SUELO ADEC = 30.92 m2
 S. SUELO S-EST3 = 8.87 m2
 S. TERRAPLEN = 195.66 m2.

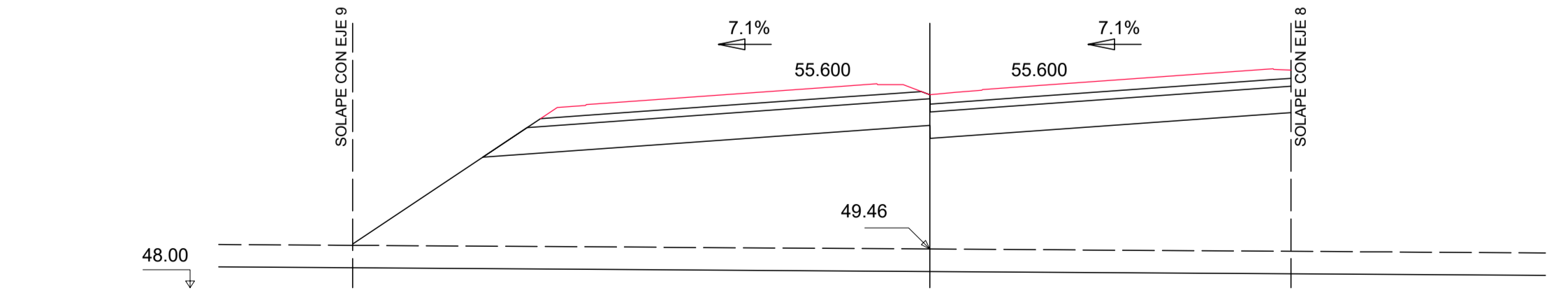

Pk=2+780
 S. FIRME = 10.99 m2 S. VEGETAL = 30.20 m2.
 S. SUELO ADEC = 29.76 m2
 S. SUELO S-EST3 = 8.57 m2
 S. TERRAPLEN = 171.10 m2.

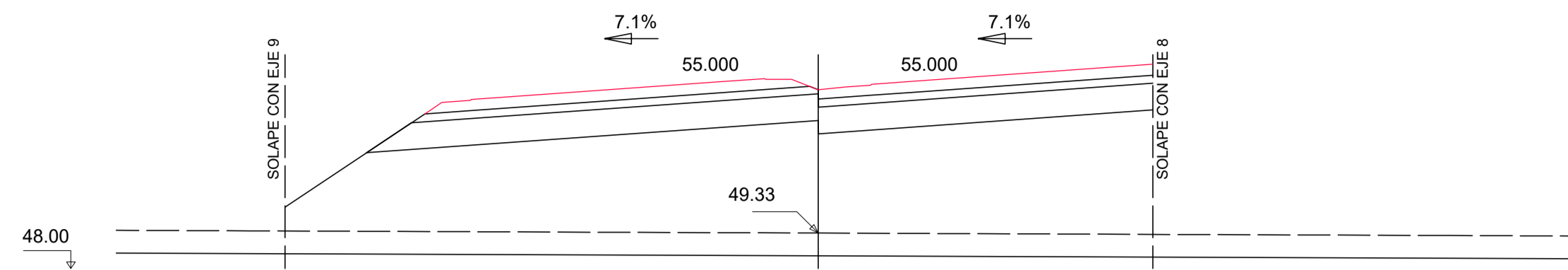
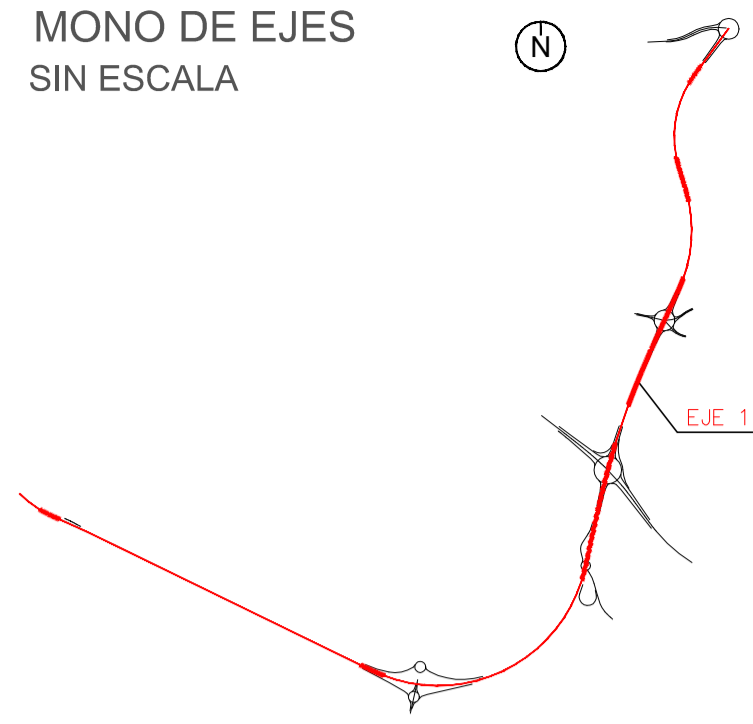

Pk=2+800
S. FIRME = 10.57 m2. S. VEGETAL = 27.64 m2.
S. SUELO ADEC = 28.62 m2.
S. SUELO S-EST3 = 8.23 m2.
S. TERRAPLEN = 146.47 m2.

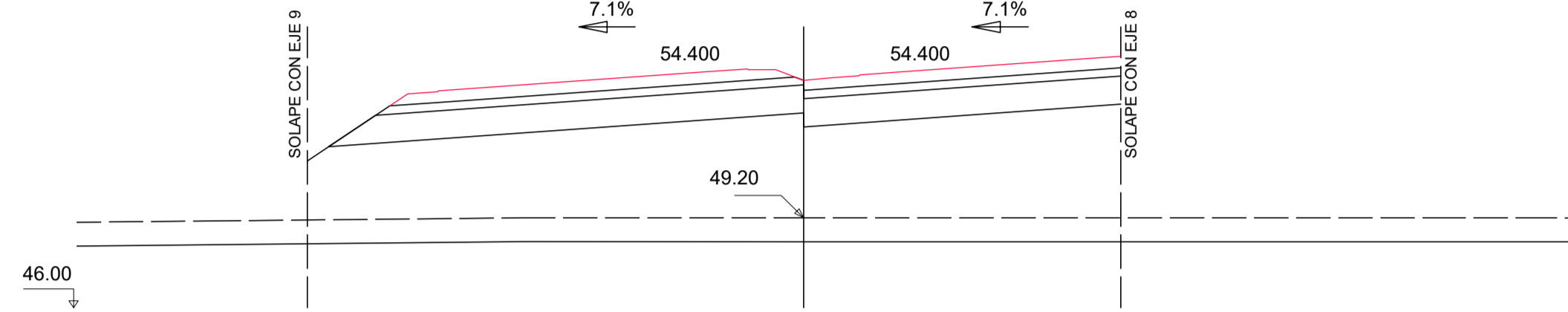

Pk=2+820
S. FIRME = 10.06 m2. S. VEGETAL = 24.63 m2.
S. SUELO ADEC = 27.38 m2.
S. SUELO S-EST3 = 7.86 m2.
S. TERRAPLEN = 120.80 m2.

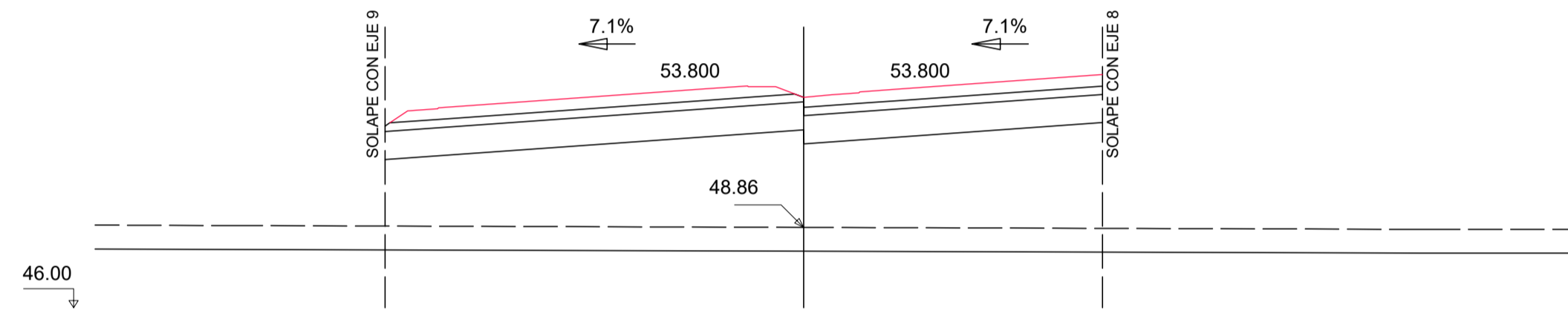

Pk=2+840
S. FIRME = 9.79 m2. S. VEGETAL = 21.72 m2.
S. SUELO ADEC = 25.55 m2.
S. SUELO S-EST3 = 7.63 m2.
S. TERRAPLEN = 101.24 m2.

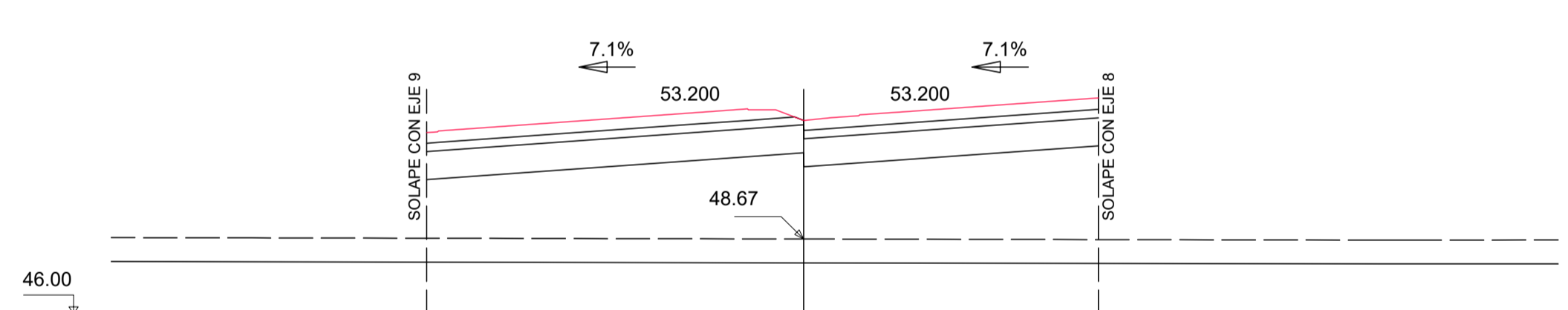

Pk=2+860
S. FIRME = 9.35 m2. S. VEGETAL = 20.33 m2.
S. SUELO ADEC = 23.92 m2.
S. SUELO S-EST3 = 7.15 m2.
S. TERRAPLEN = 86.02 m2.

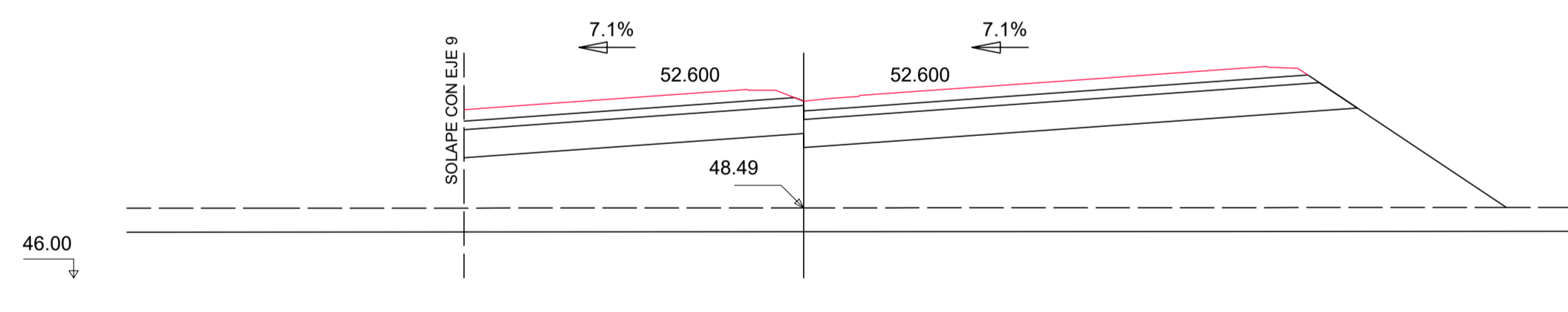

Pk=2+880
S. FIRME = 11.68 m2. S. VEGETAL = 31.56 m2.
S. SUELO ADEC = 31.14 m2.
S. SUELO S-EST3 = 9.05 m2.
S. TERRAPLEN = 123.92 m2.

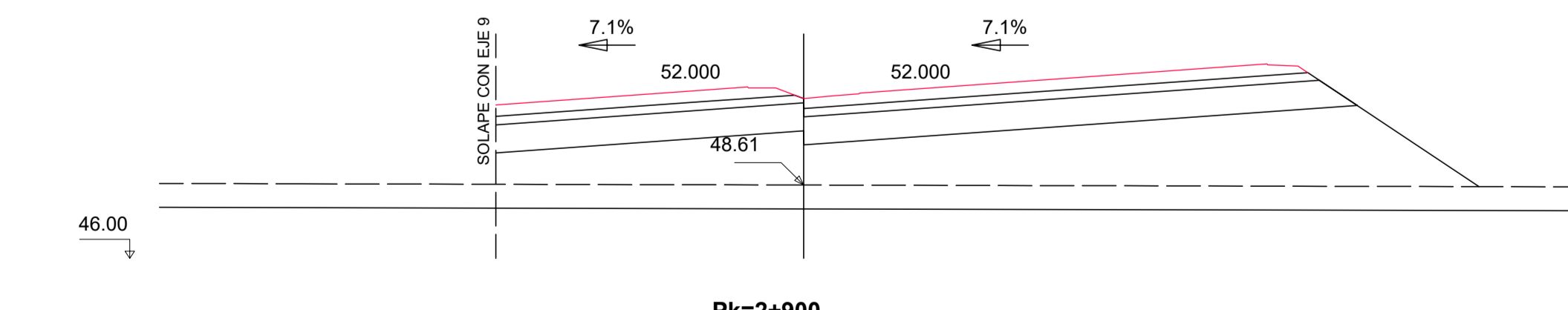

Pk=2+900
S. FIRME = 11.21 m2. S. VEGETAL = 29.76 m2.
S. SUELO ADEC = 30.00 m2.
S. SUELO S-EST3 = 8.71 m2.
S. TERRAPLEN = 95.23 m2.

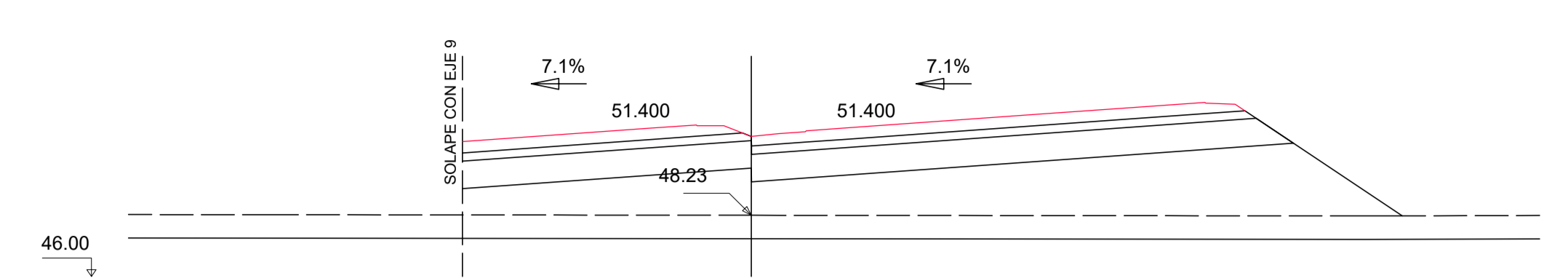

Pk=2+920
S. FIRME = 11.03 m2. S. VEGETAL = 29.05 m2.
S. SUELO ADEC = 29.54 m2.
S. SUELO S-EST3 = 8.57 m2.
S. TERRAPLEN = 86.33 m2.

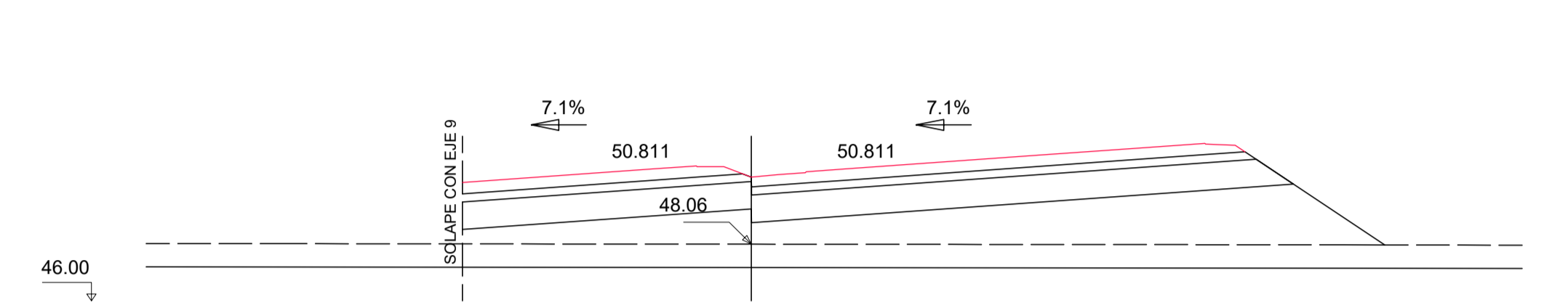

Pk=2+940
S. FIRME = 11.03 m2. S. VEGETAL = 28.51 m2.
S. SUELO ADEC = 29.54 m2.
S. SUELO S-EST3 = 8.57 m2.
S. TERRAPLEN = 71.27 m2.

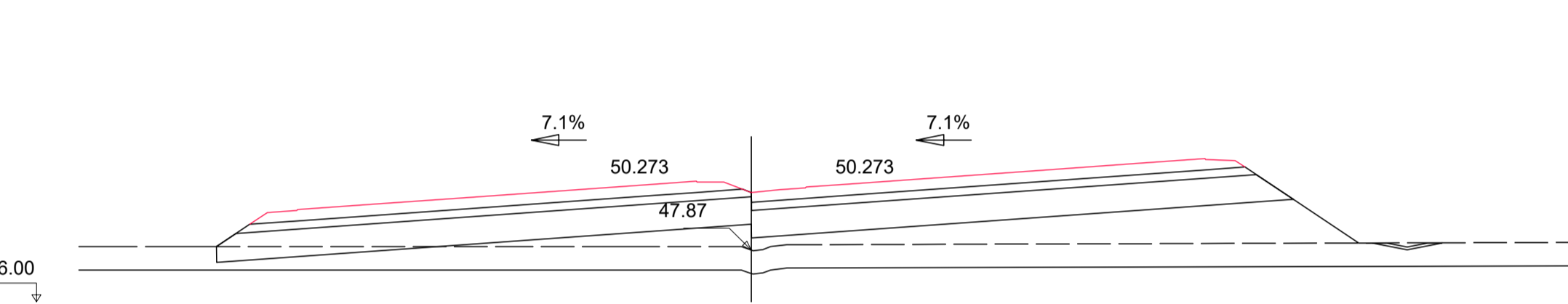

Pk=2+960
S. FIRME = 14.03 m2. S. REV CUN GUARDA = 0.20 m2. S. VEGETAL = 37.90 m2.
S. SUELO ADEC = 38.34 m2.
S. SUELO S-EST3 = 10.97 m2.
S. TERRAPLEN = 60.13 m2.

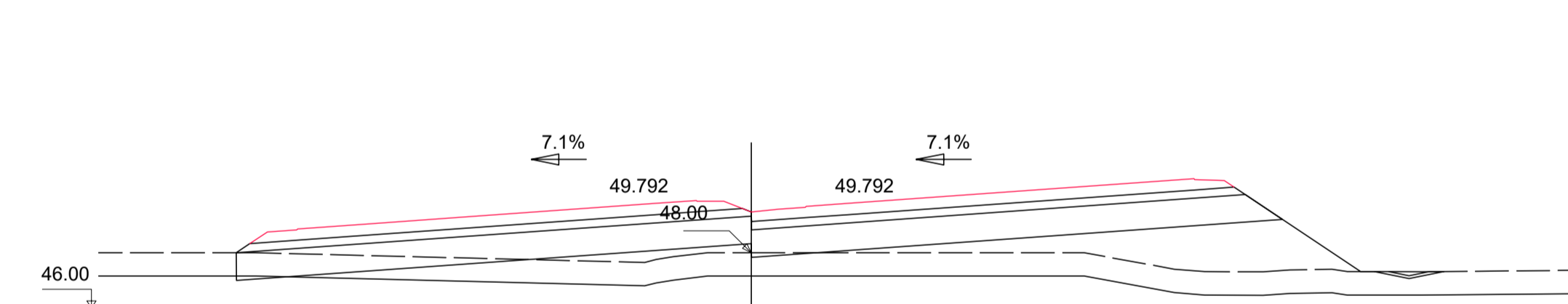

Pk=2+980
S. FIRME = 13.86 m2. S. TERRAPLEN = 50.00 m2.
S. D TIERRA = 0.15 m2. S. REV CUN GUARDA = 0.20 m2. S. VEGETAL = 37.34 m2.
S. SUELO ADEC = 37.38 m2.
S. SUELO S-EST3 = 10.85 m2.

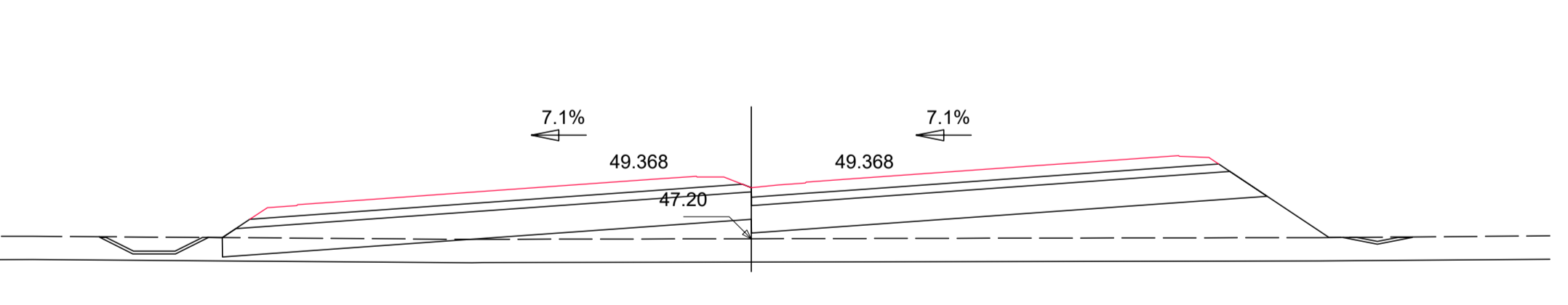

Pk=3+000
S. FIRME = 13.63 m2. S. REV CUN GUARDA = 0.60 m2. S. VEGETAL = 40.60 m2.
S. D TIERRA = 0.04 m2.
S. SUELO ADEC = 37.25 m2.
S. SUELO S-EST3 = 10.68 m2.
S. TERRAPLEN = 56.85 m2.

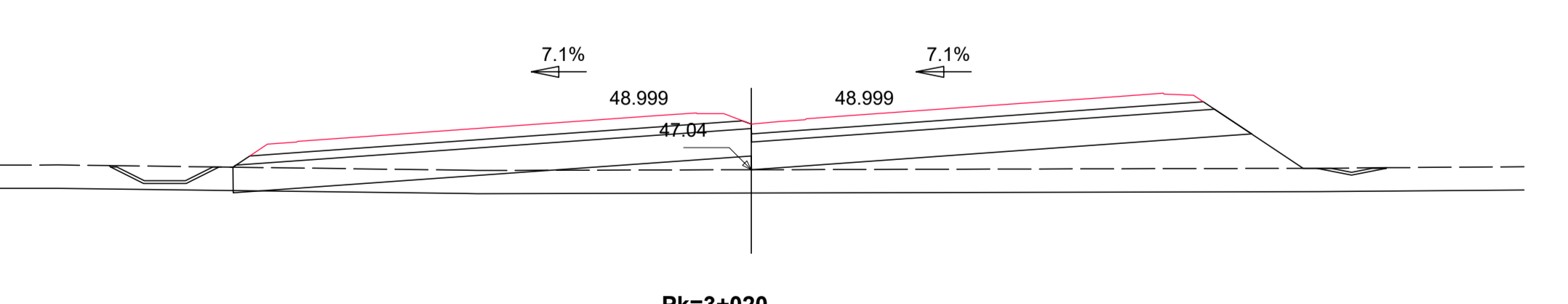

Pk=3+020
S. FIRME = 13.40 m2. S. TERRAPLEN = 46.67 m2.
S. D TIERRA = 0.04 m2. S. REV CUN GUARDA = 0.60 m2. S. VEGETAL = 39.50 m2.
S. SUELO ADEC = 36.37 m2.
S. SUELO S-EST3 = 10.51 m2.

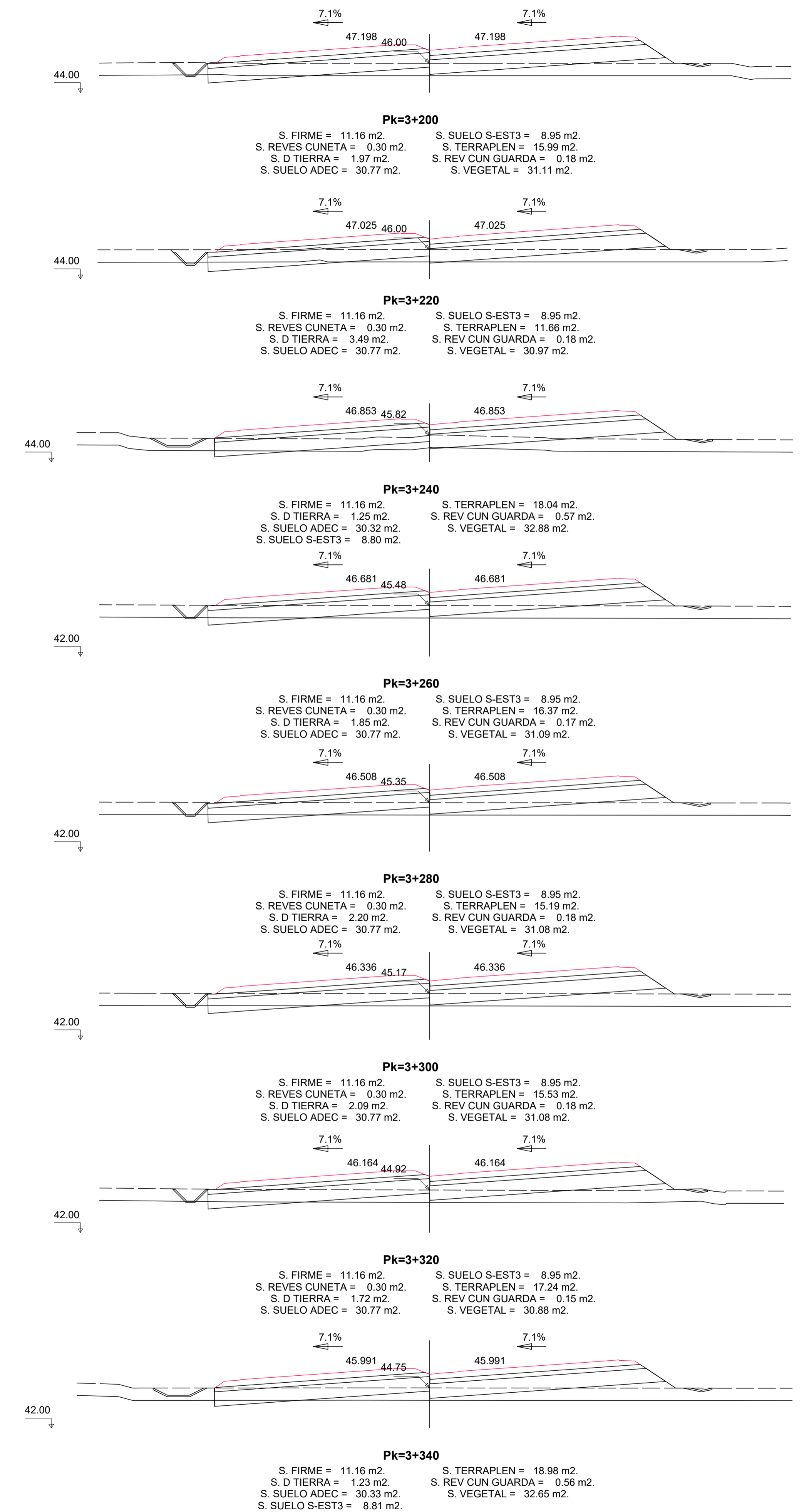
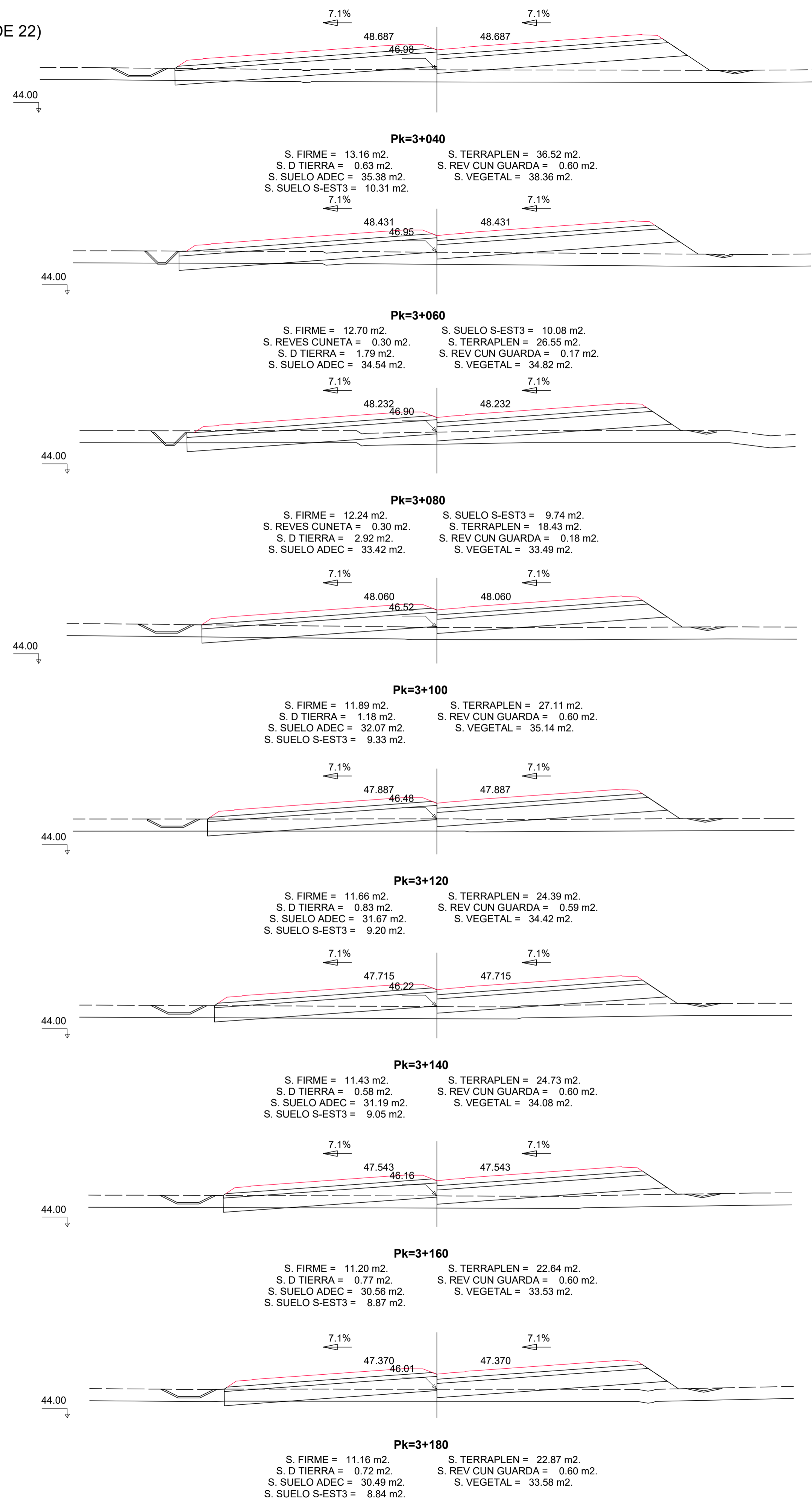
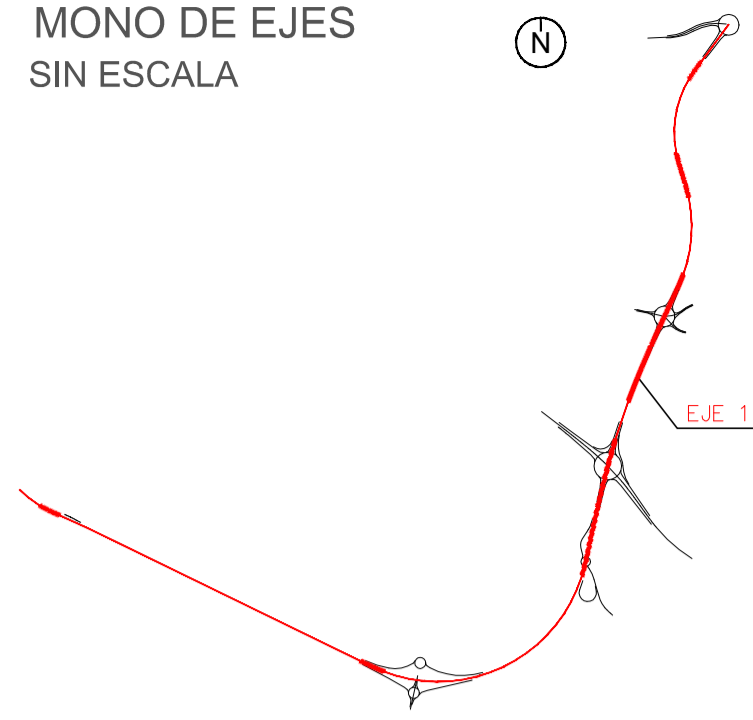

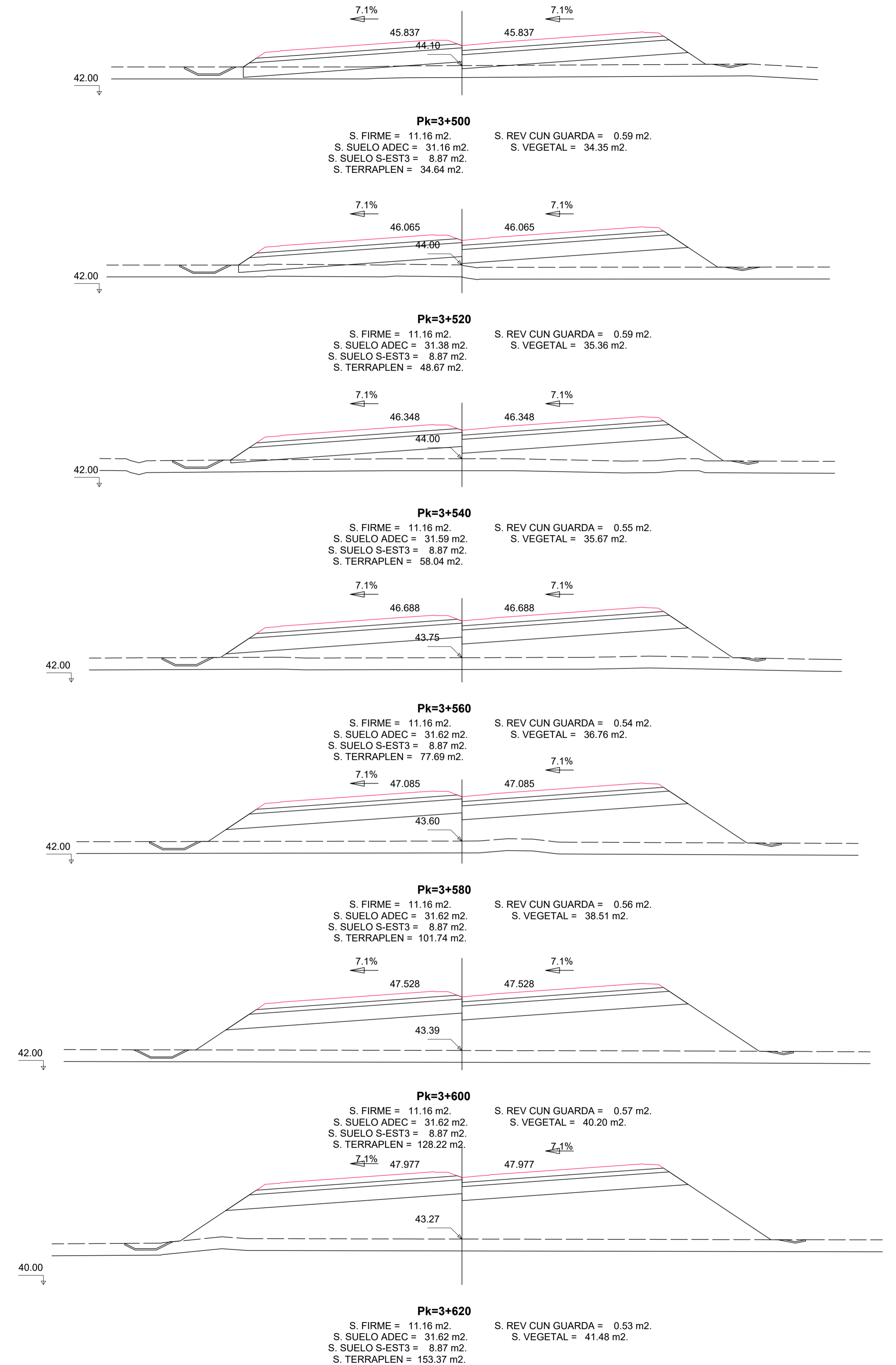
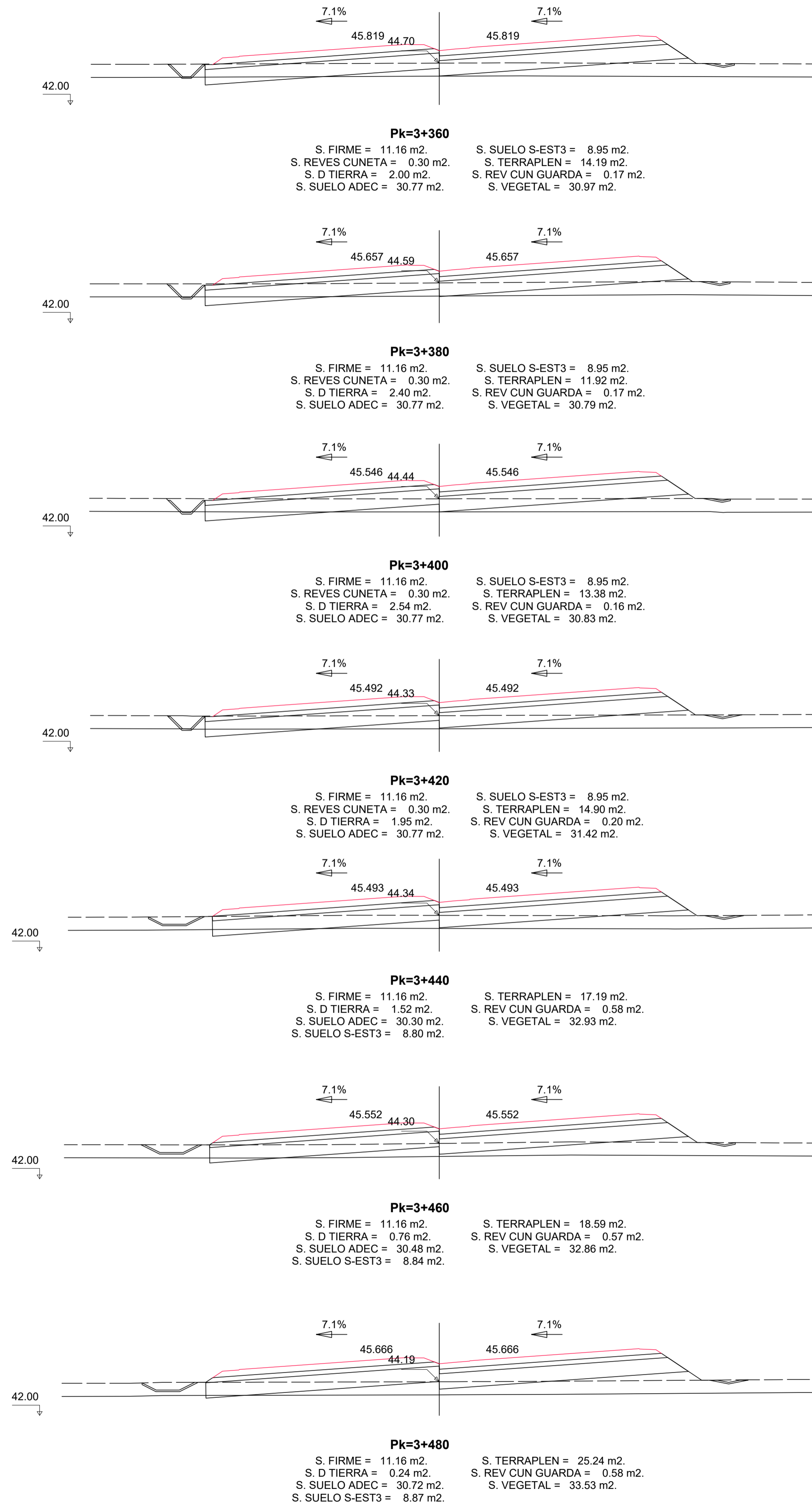
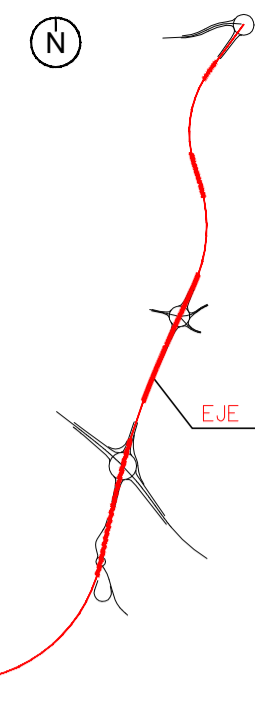

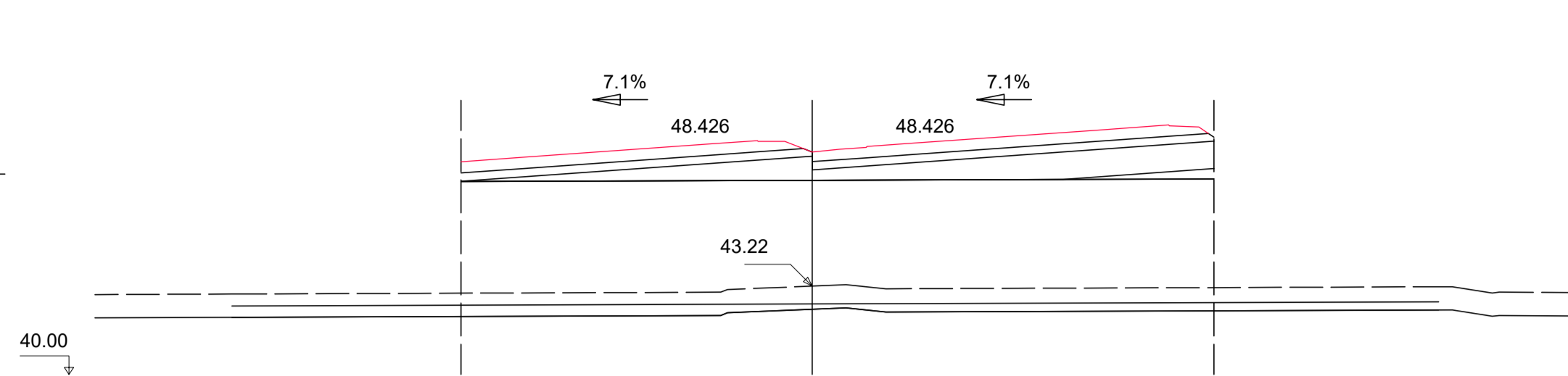
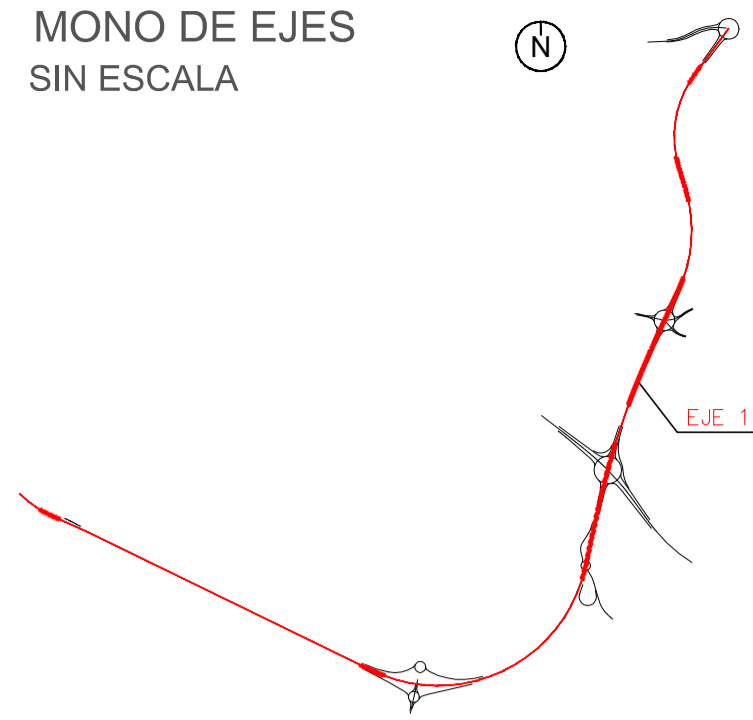

PK=3+640
 S. FIRME = 10.54 m2. S. VEGETAL = 37.41 m2.
 S. SUELO ADEC = 17.51 m2. S. REL EXC OF = 14.73 m2.
 S. SUELO S-EST3 = 8.20 m2.
 S. TERRAPLEN = 1.03 m2.

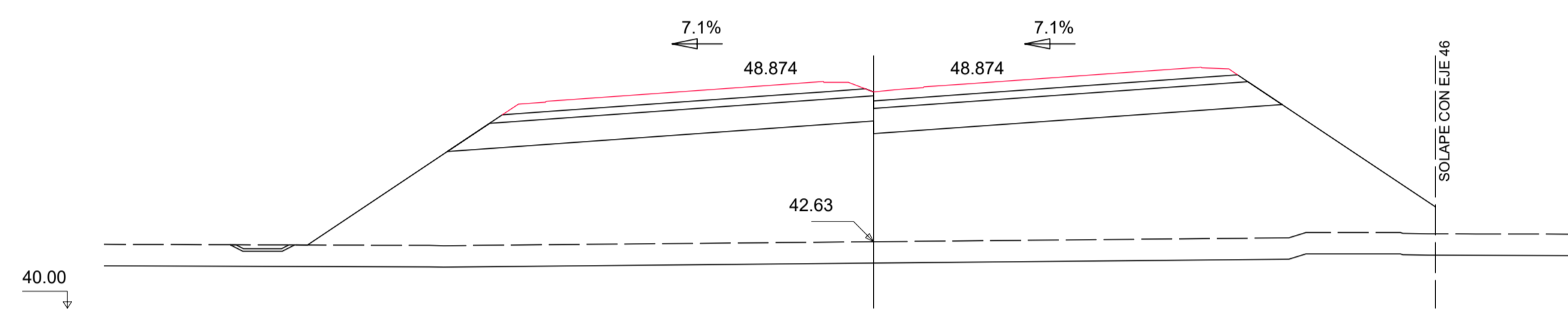

PK=3+660
 S. FIRME = 11.16 m2. S. REV CUN GUARDA = 0.24 m2.
 S. SUELO ADEC = 31.62 m2. S. VEGETAL = 40.67 m2.
 S. SUELO S-EST3 = 8.87 m2.
 S. TERRAPLEN = 218.83 m2.

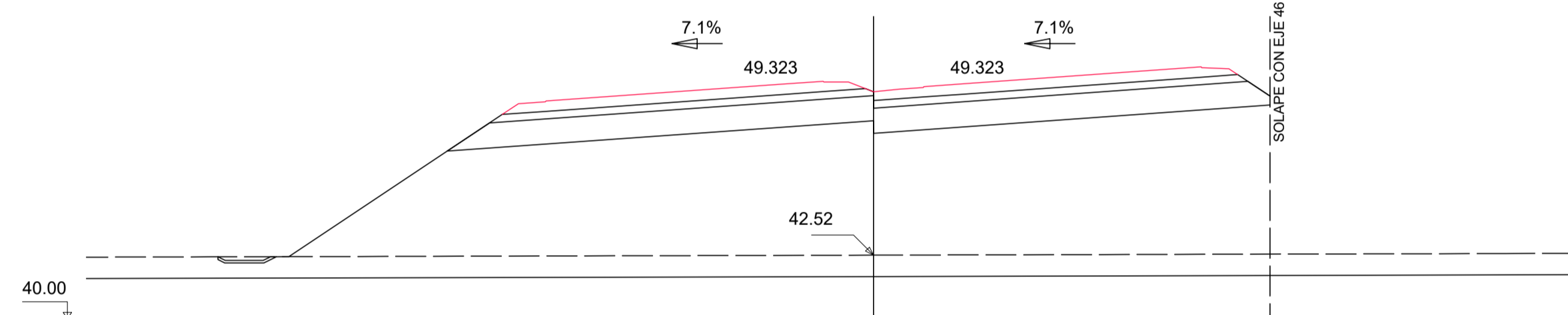

PK=3+680
 S. FIRME = 11.16 m2. S. REV CUN GUARDA = 0.23 m2.
 S. SUELO ADEC = 31.54 m2. S. VEGETAL = 35.50 m2.
 S. SUELO S-EST3 = 8.87 m2.
 S. TERRAPLEN = 213.29 m2.

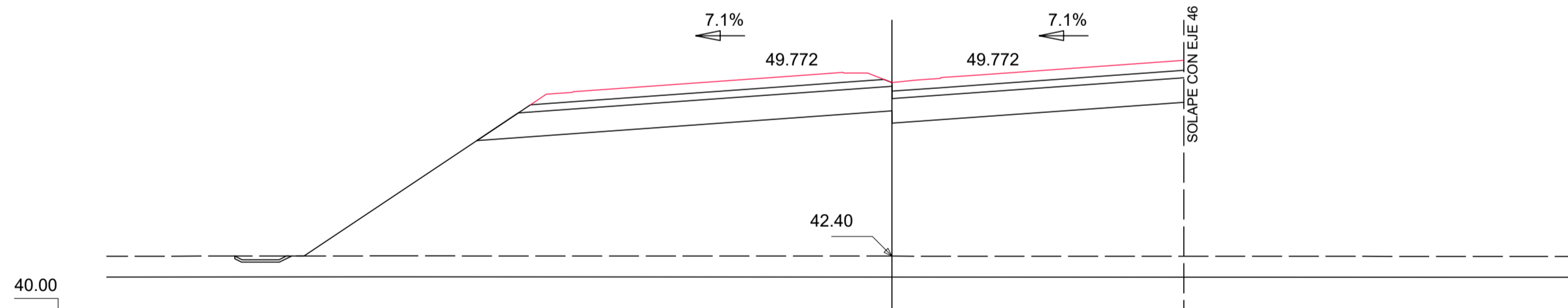

PK=3+700
 S. FIRME = 10.30 m2. S. REV CUN GUARDA = 0.23 m2.
 S. SUELO ADEC = 27.99 m2. S. VEGETAL = 32.89 m2.
 S. SUELO S-EST3 = 8.04 m2.
 S. TERRAPLEN = 208.25 m2.

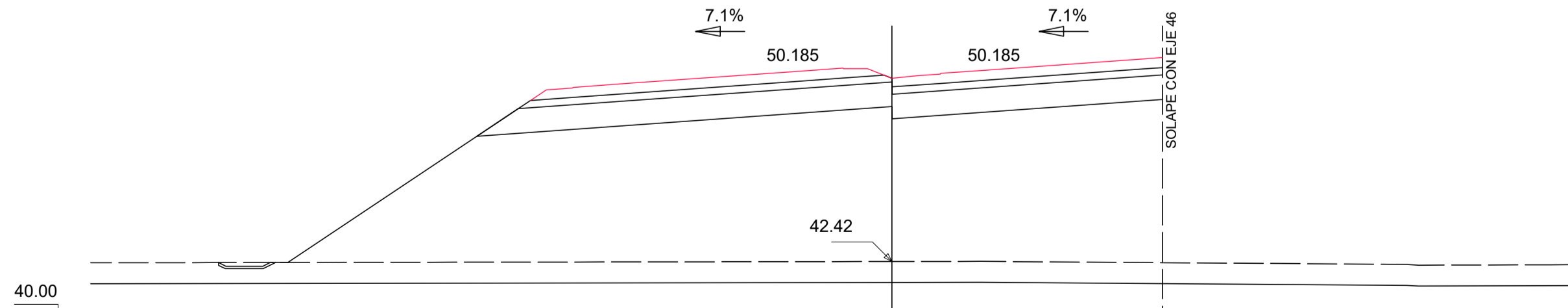

PK=3+720
 S. FIRME = 9.95 m2. S. REV CUN GUARDA = 0.23 m2.
 S. SUELO ADEC = 27.11 m2. S. VEGETAL = 32.71 m2.
 S. SUELO S-EST3 = 7.78 m2.
 S. TERRAPLEN = 217.28 m2.

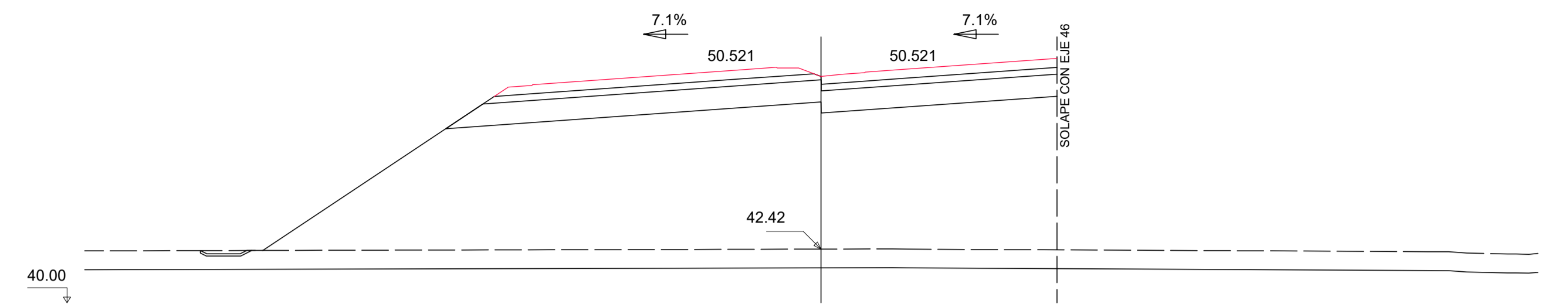

PK=3+740
 S. FIRME = 9.79 m2. S. REV CUN GUARDA = 0.23 m2.
 S. SUELO ADEC = 26.73 m2. S. VEGETAL = 32.83 m2.
 S. SUELO S-EST3 = 7.66 m2.
 S. TERRAPLEN = 226.98 m2.

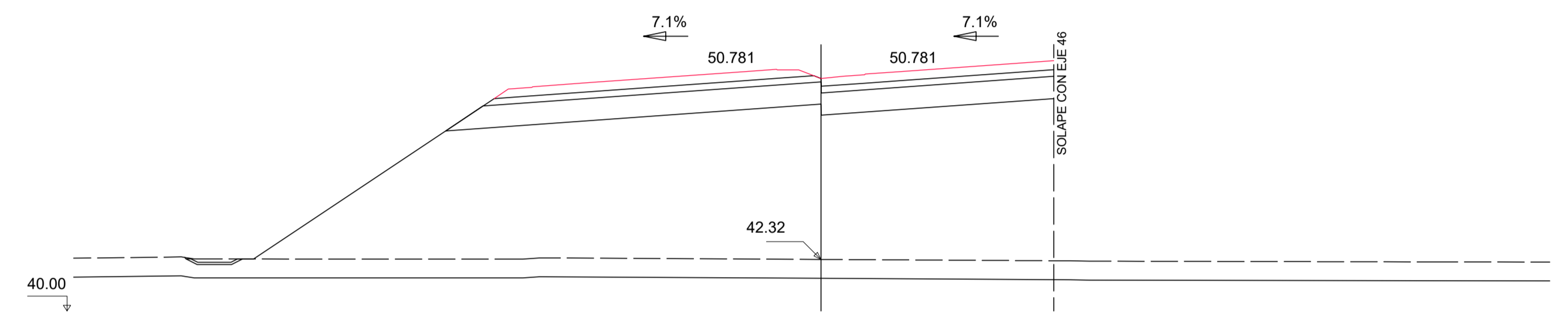

PK=3+760
 S. FIRME = 9.73 m2. S. REV CUN GUARDA = 0.24 m2.
 S. SUELO ADEC = 26.58 m2. S. VEGETAL = 33.32 m2.
 S. SUELO S-EST3 = 7.62 m2.
 S. TERRAPLEN = 238.02 m2.

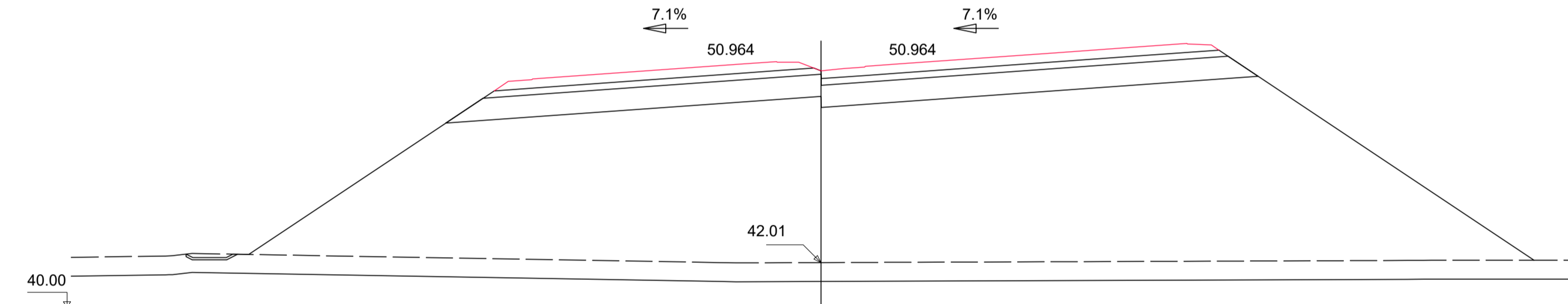

PK=3+780
 S. FIRME = 12.59 m2. S. REV CUN GUARDA = 0.23 m2.
 S. SUELO ADEC = 35.12 m2. S. VEGETAL = 51.67 m2.
 S. SUELO S-EST3 = 9.92 m2.
 S. TERRAPLEN = 396.01 m2.

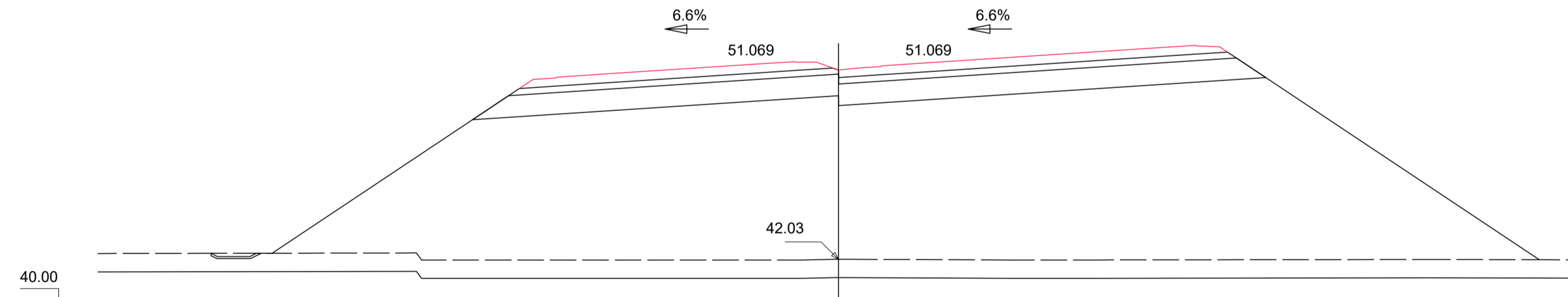

PK=3+800
 S. FIRME = 12.60 m2. S. REV CUN GUARDA = 0.23 m2.
 S. SUELO ADEC = 35.12 m2. S. VEGETAL = 52.13 m2.
 S. SUELO S-EST3 = 9.93 m2.
 S. TERRAPLEN = 406.13 m2.

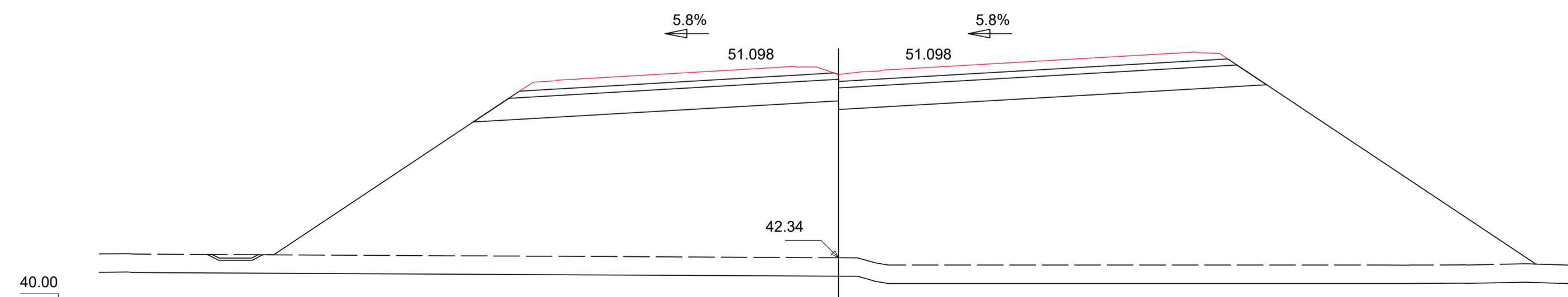

PK=3+820
 S. FIRME = 12.62 m2. S. REV CUN GUARDA = 0.24 m2.
 S. SUELO ADEC = 35.13 m2. S. VEGETAL = 52.14 m2.
 S. SUELO S-EST3 = 9.94 m2.
 S. TERRAPLEN = 398.27 m2.

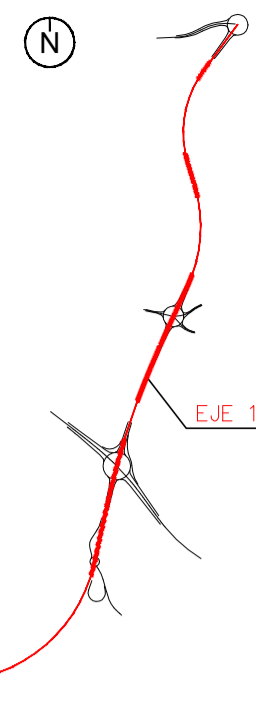

EJE 1 (HOJA 15 DE 22)

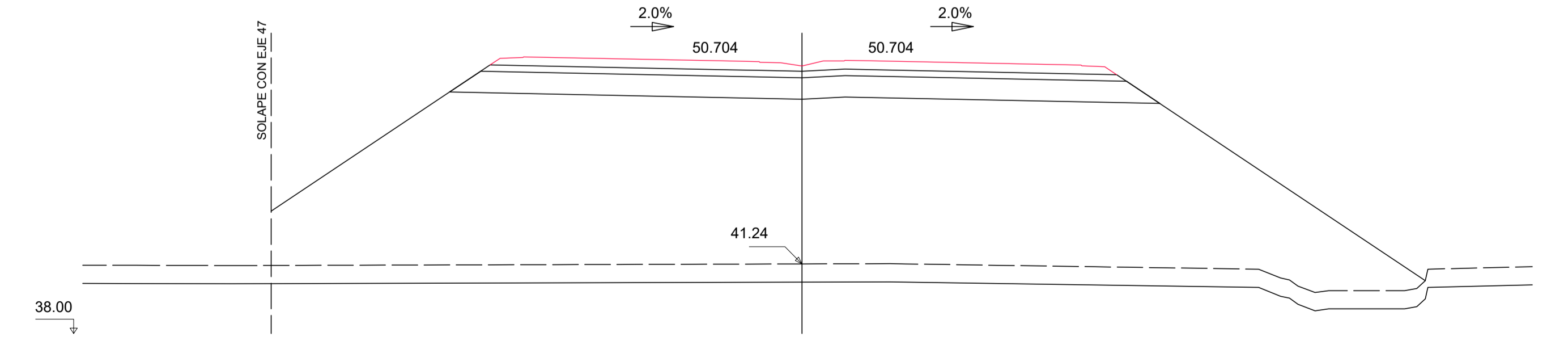
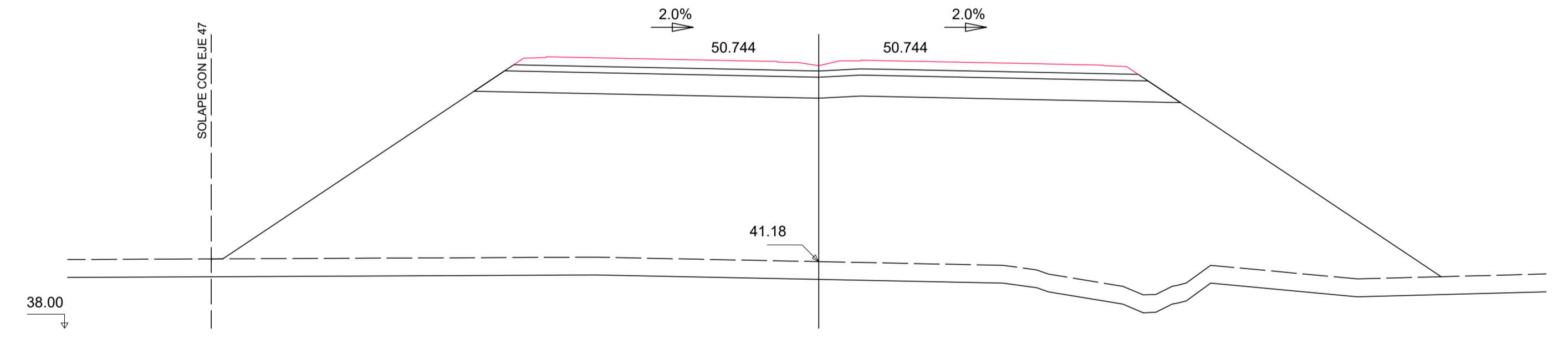
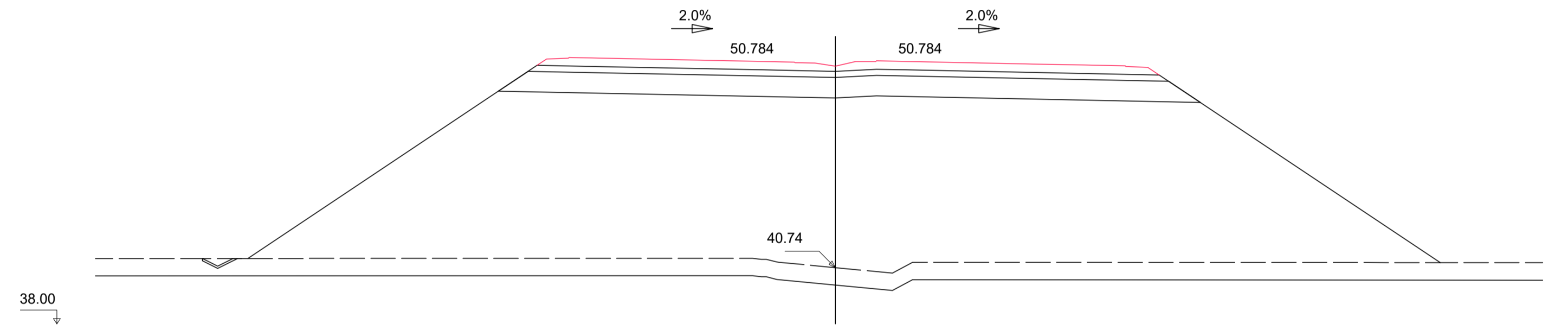
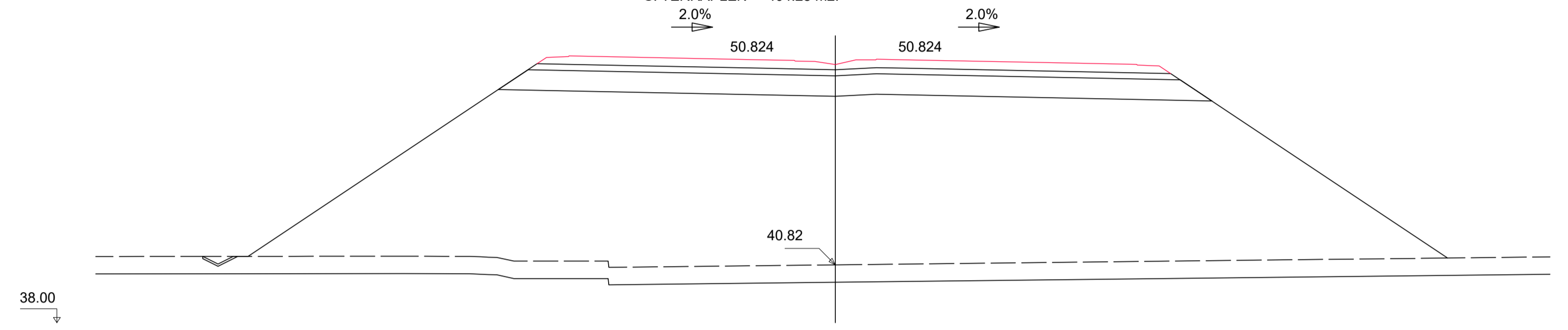
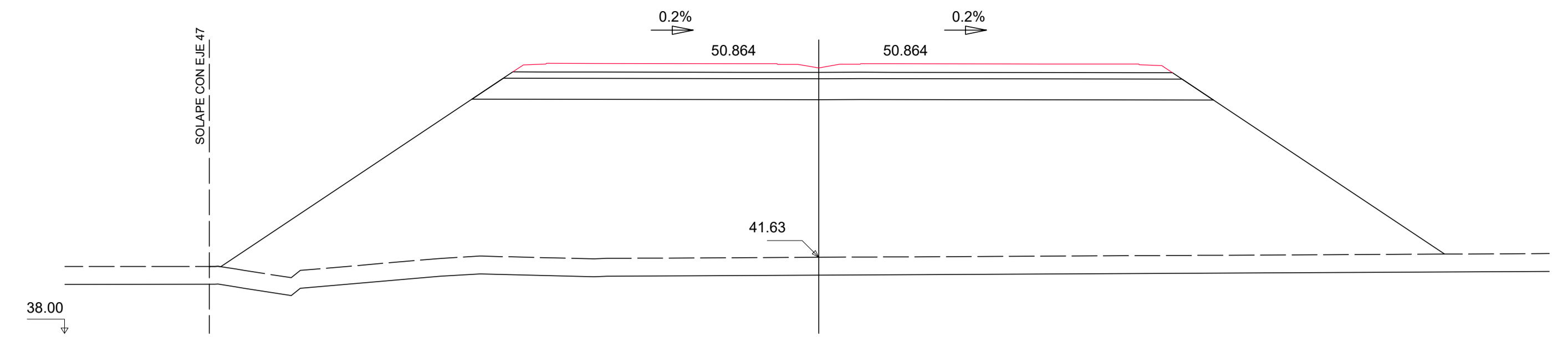
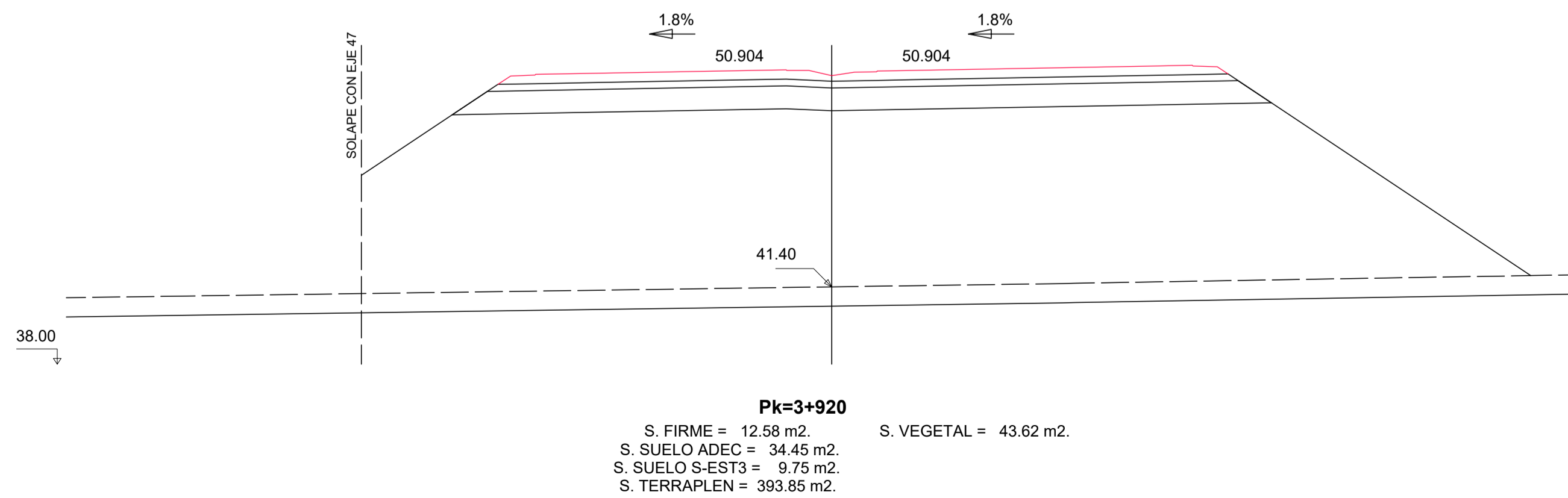
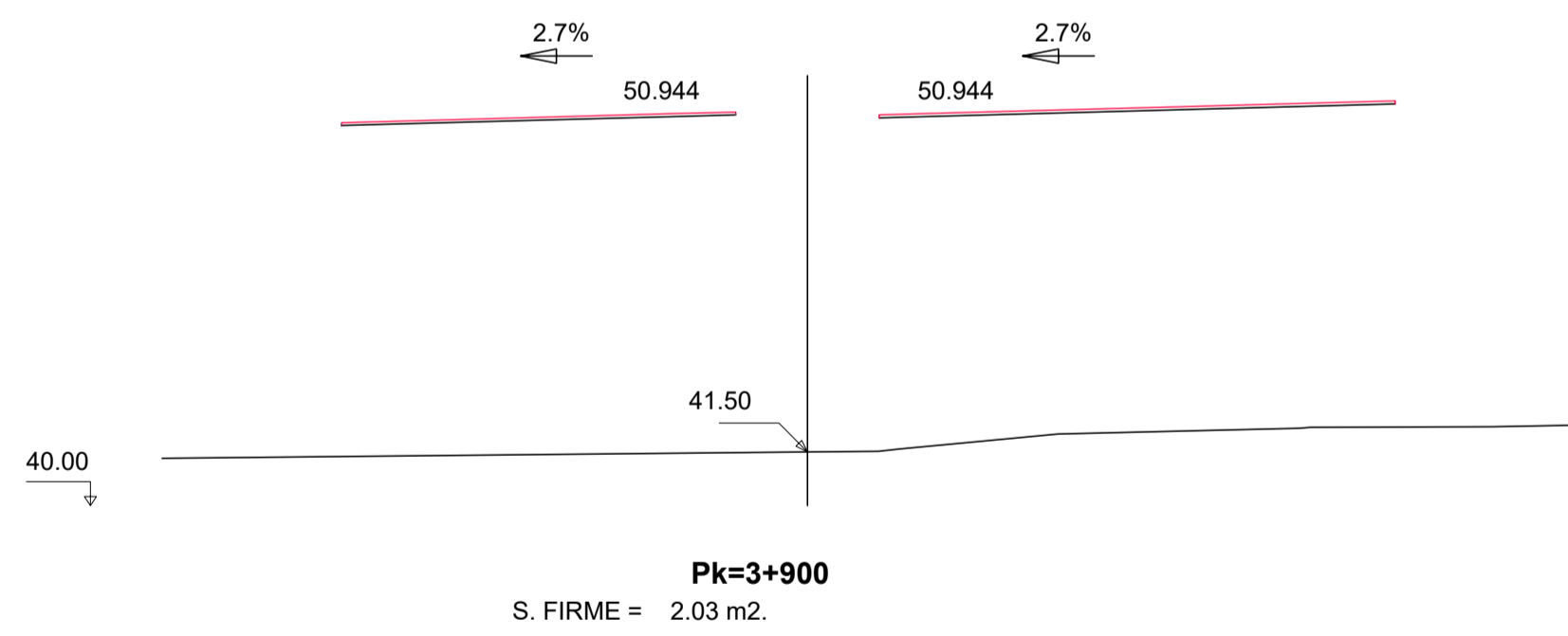
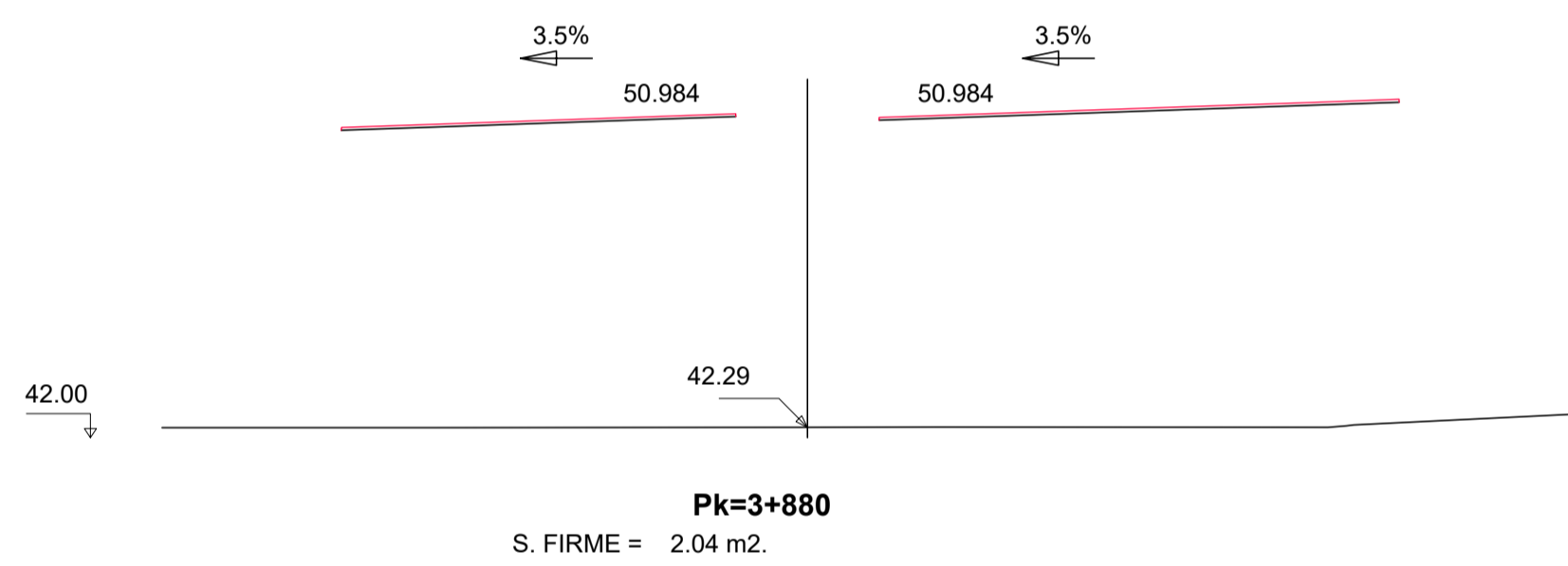
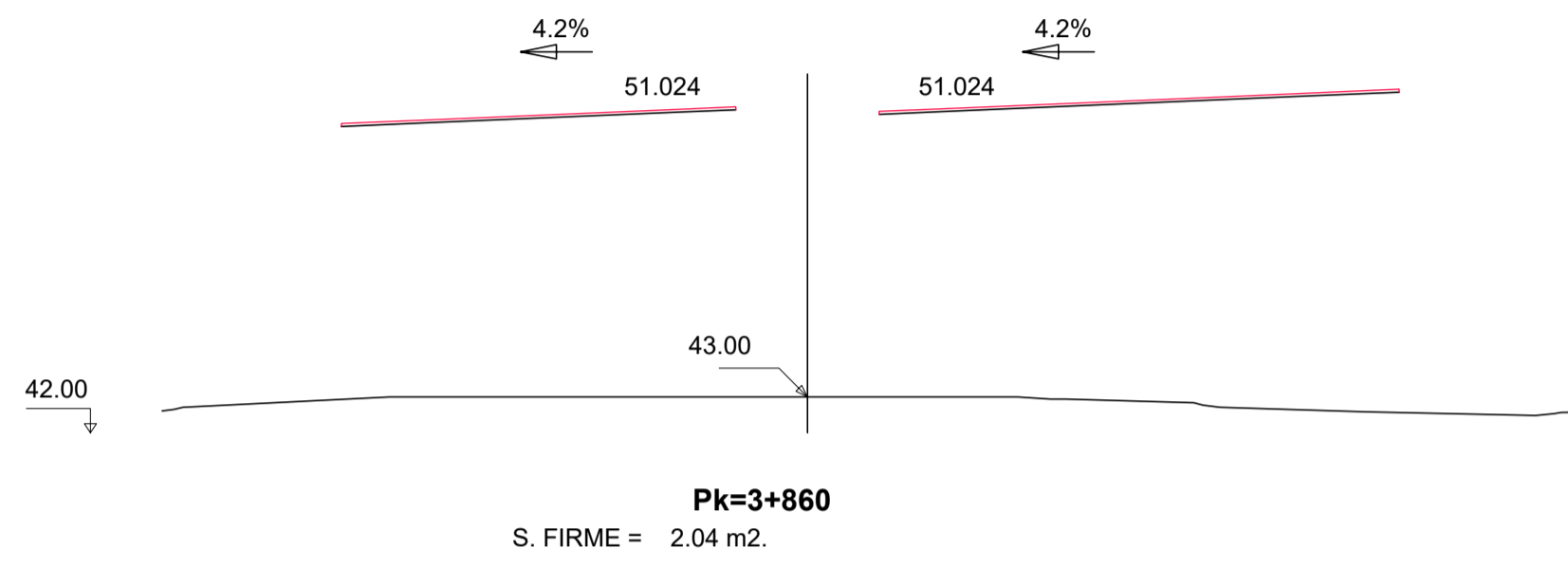
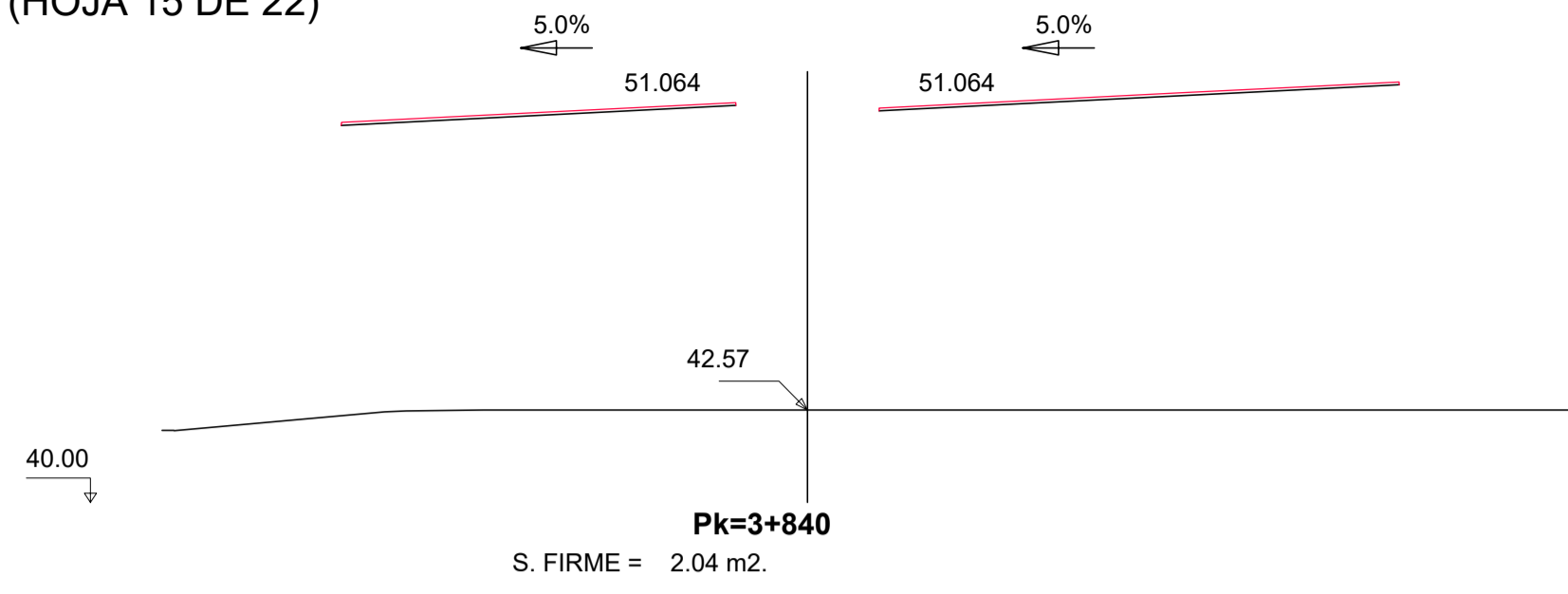

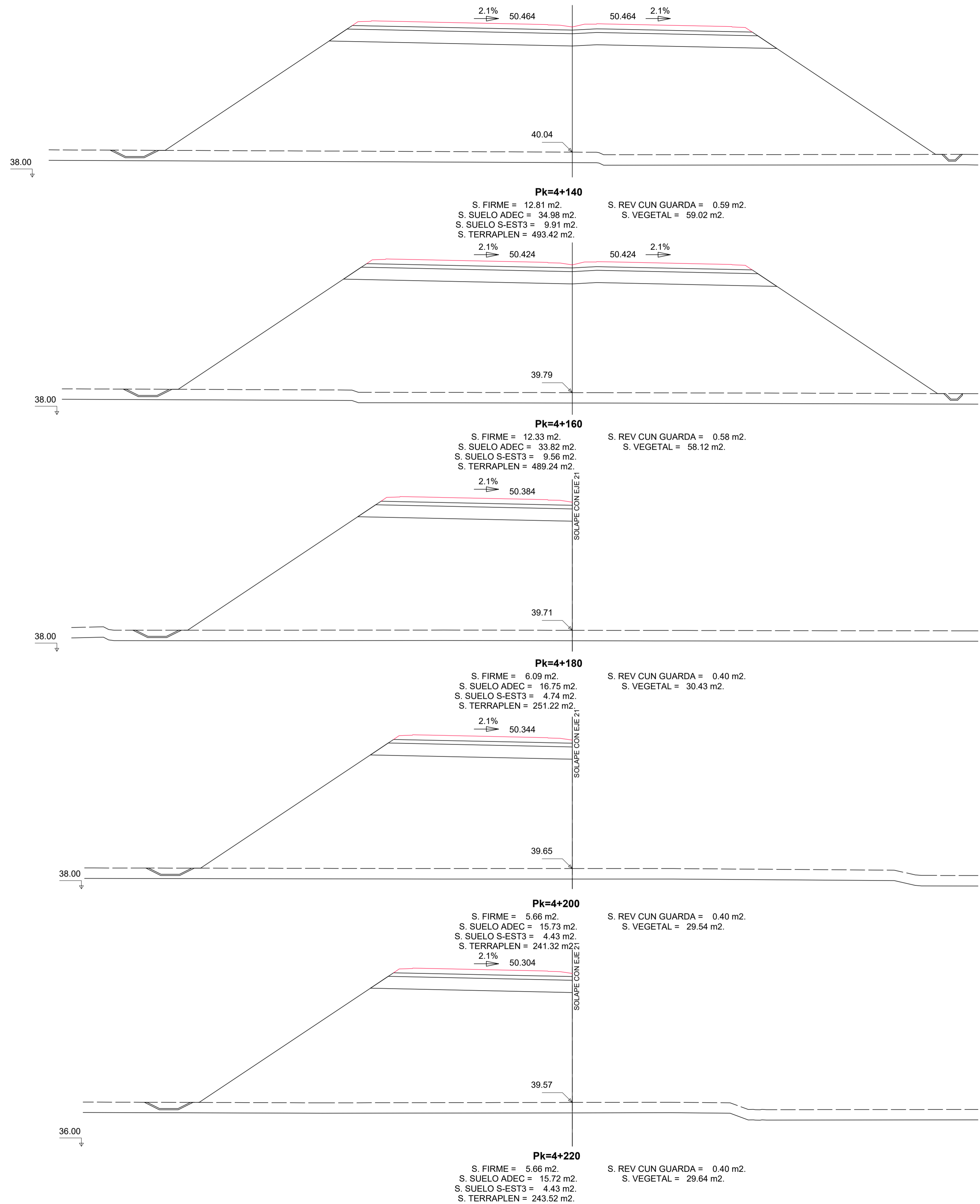
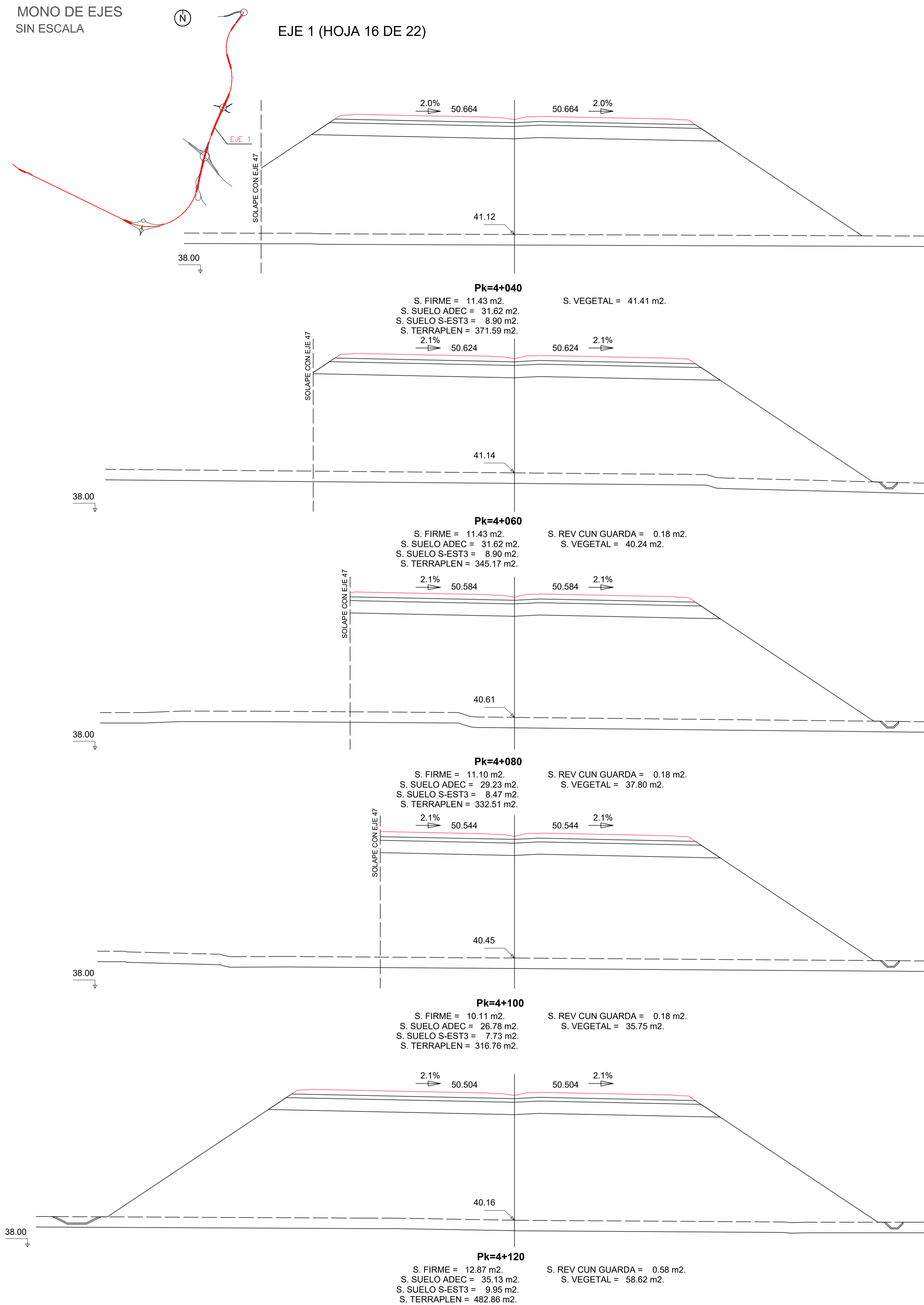

MONO DE EJES
SIN ESCALA

(N)

EJE 1 (HOJA 17 DE 22)

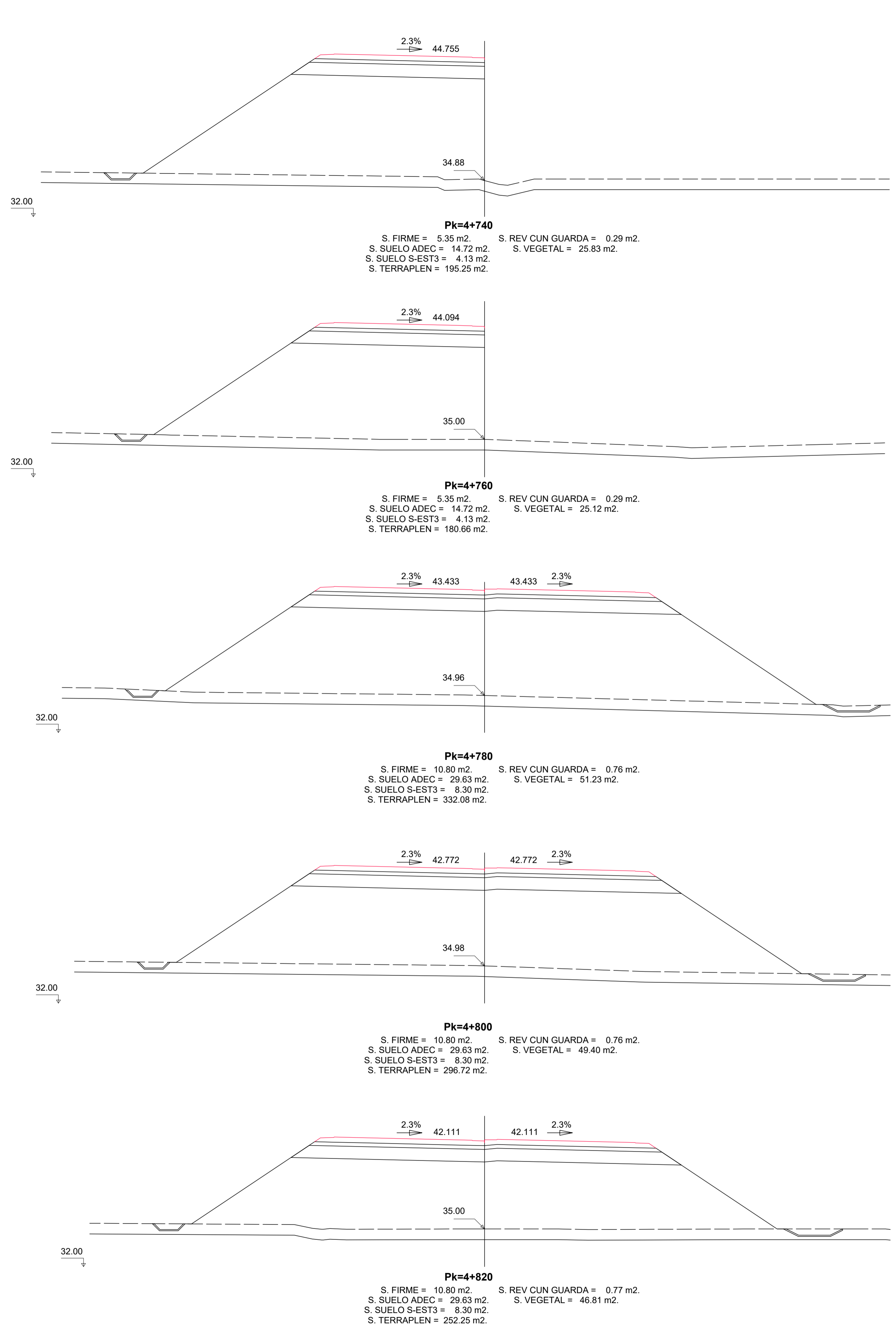
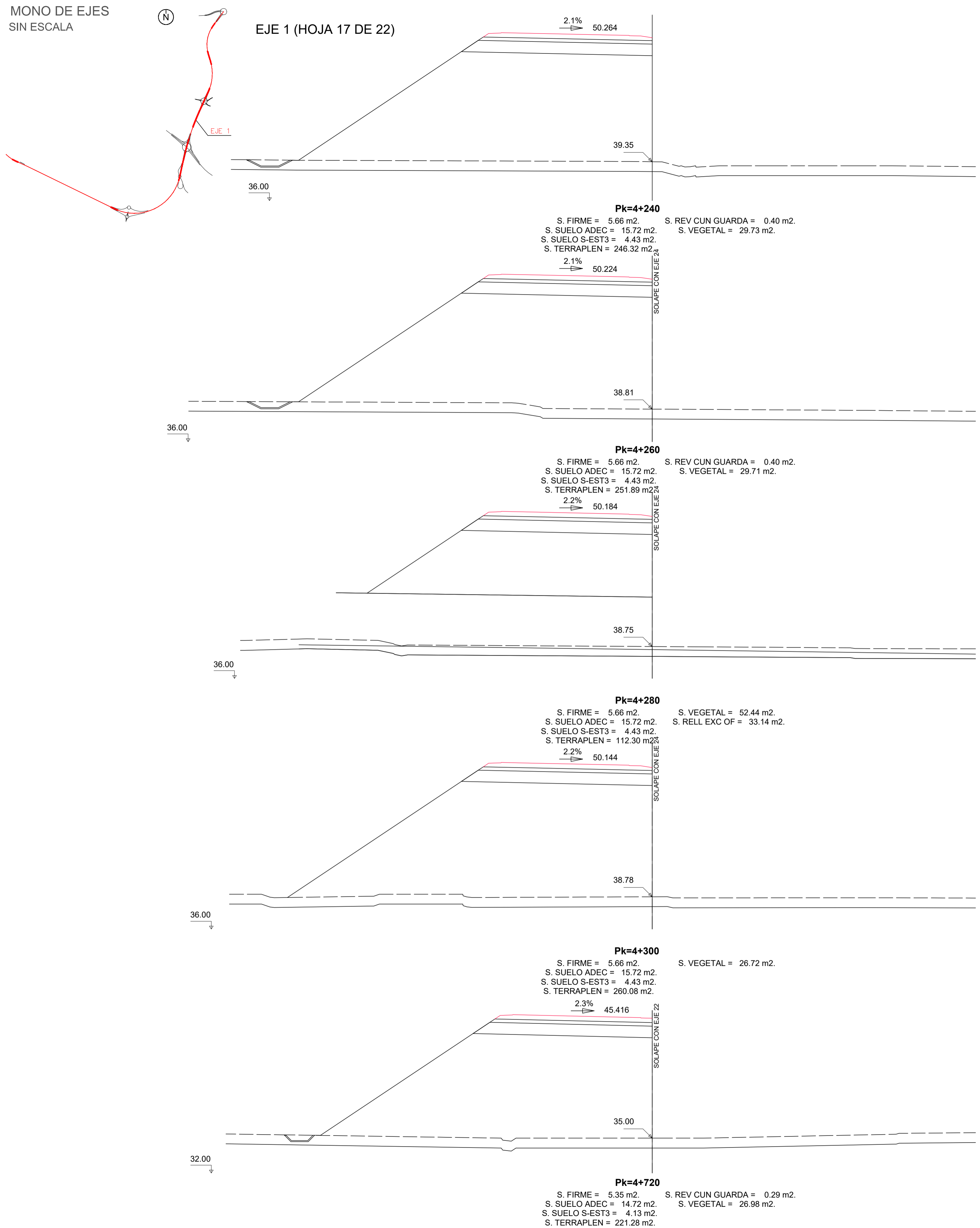

MONO DE EJES
SIN ESCALA

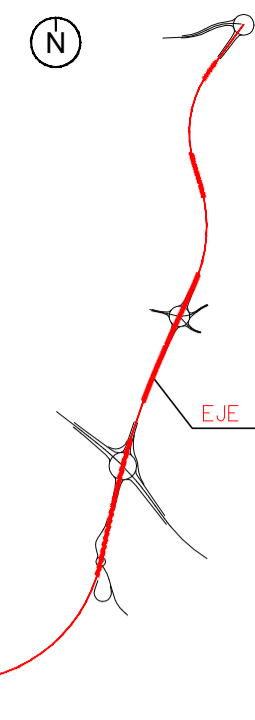

EJE 1 (HOJA 18 DE 22)

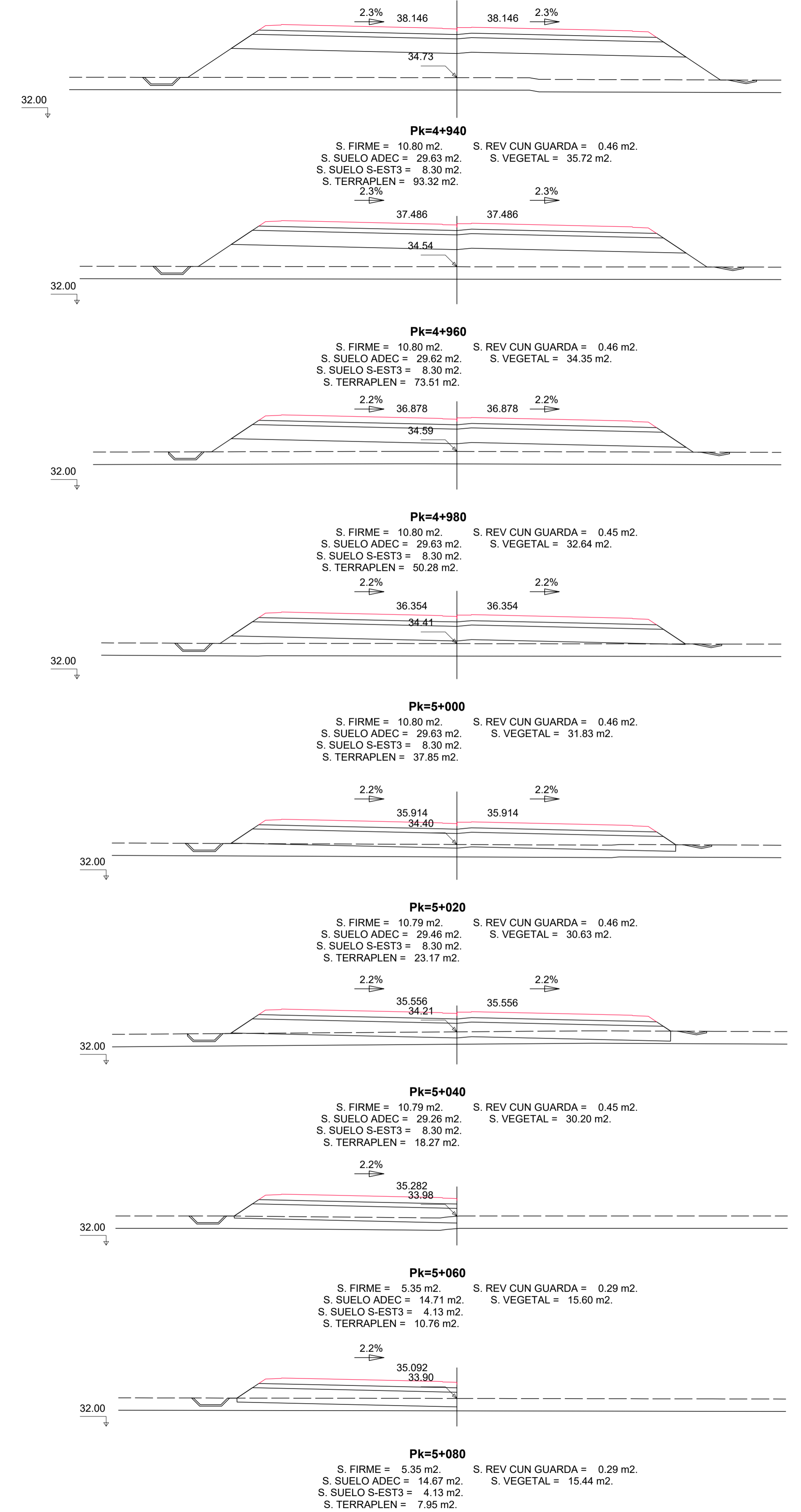
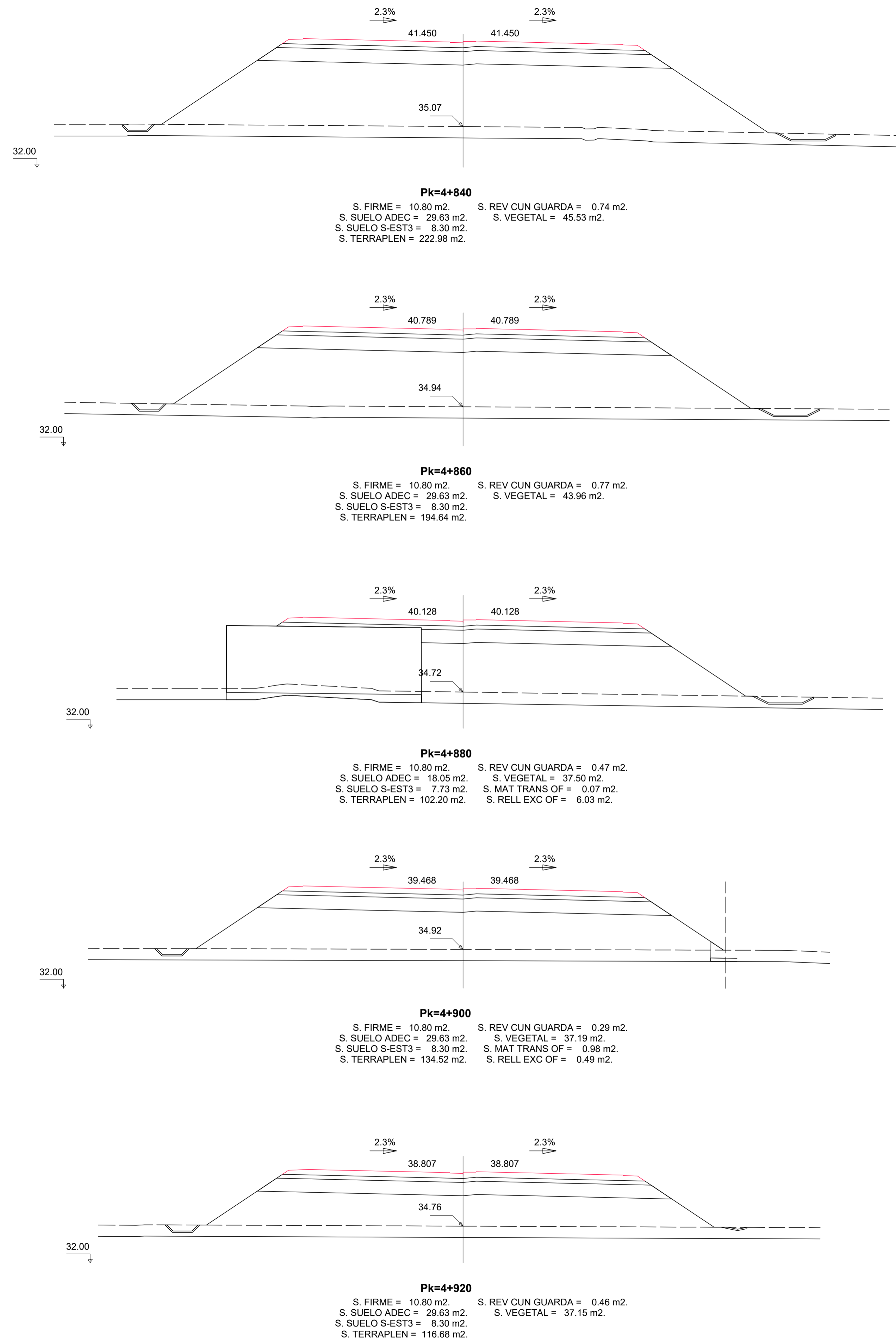

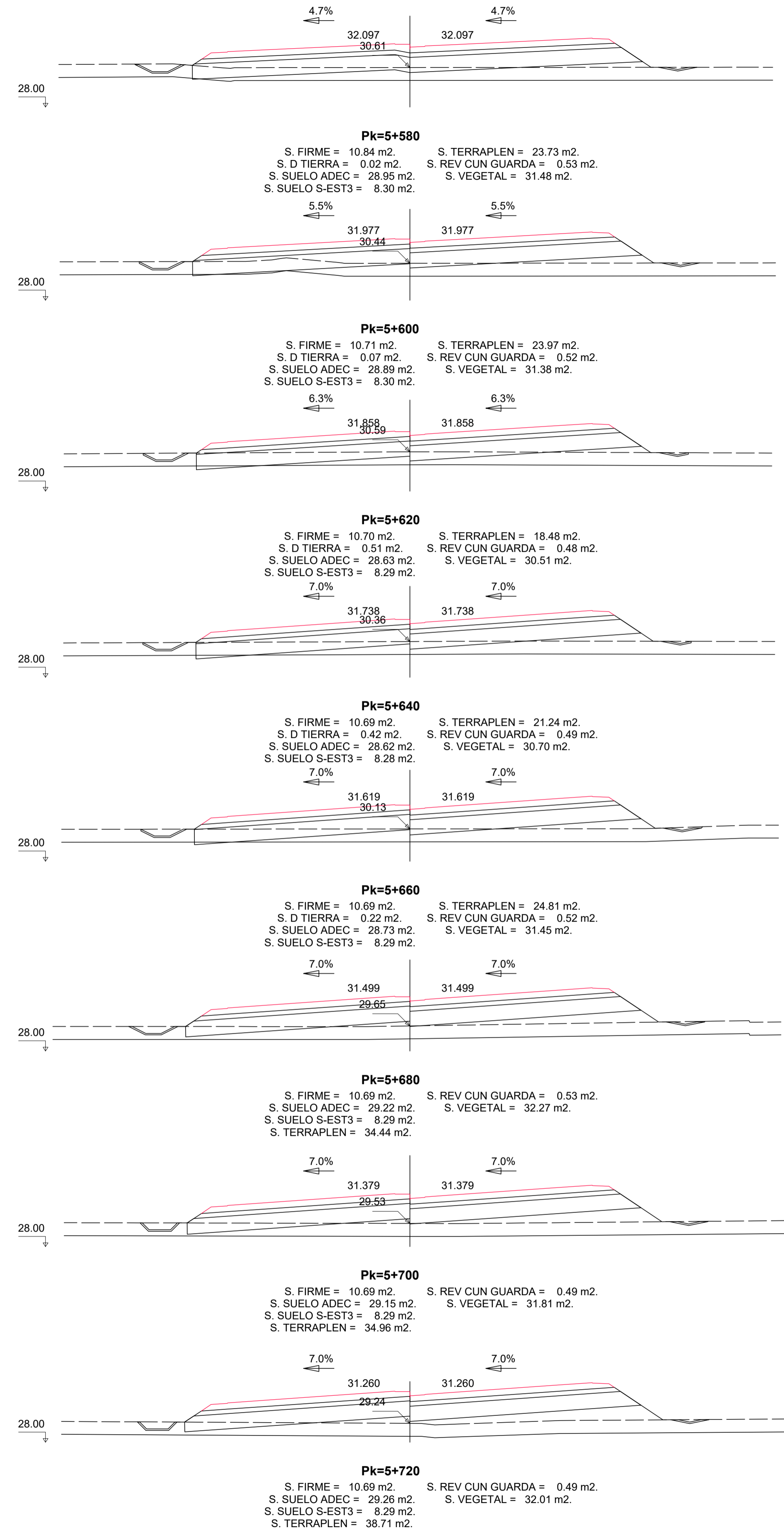
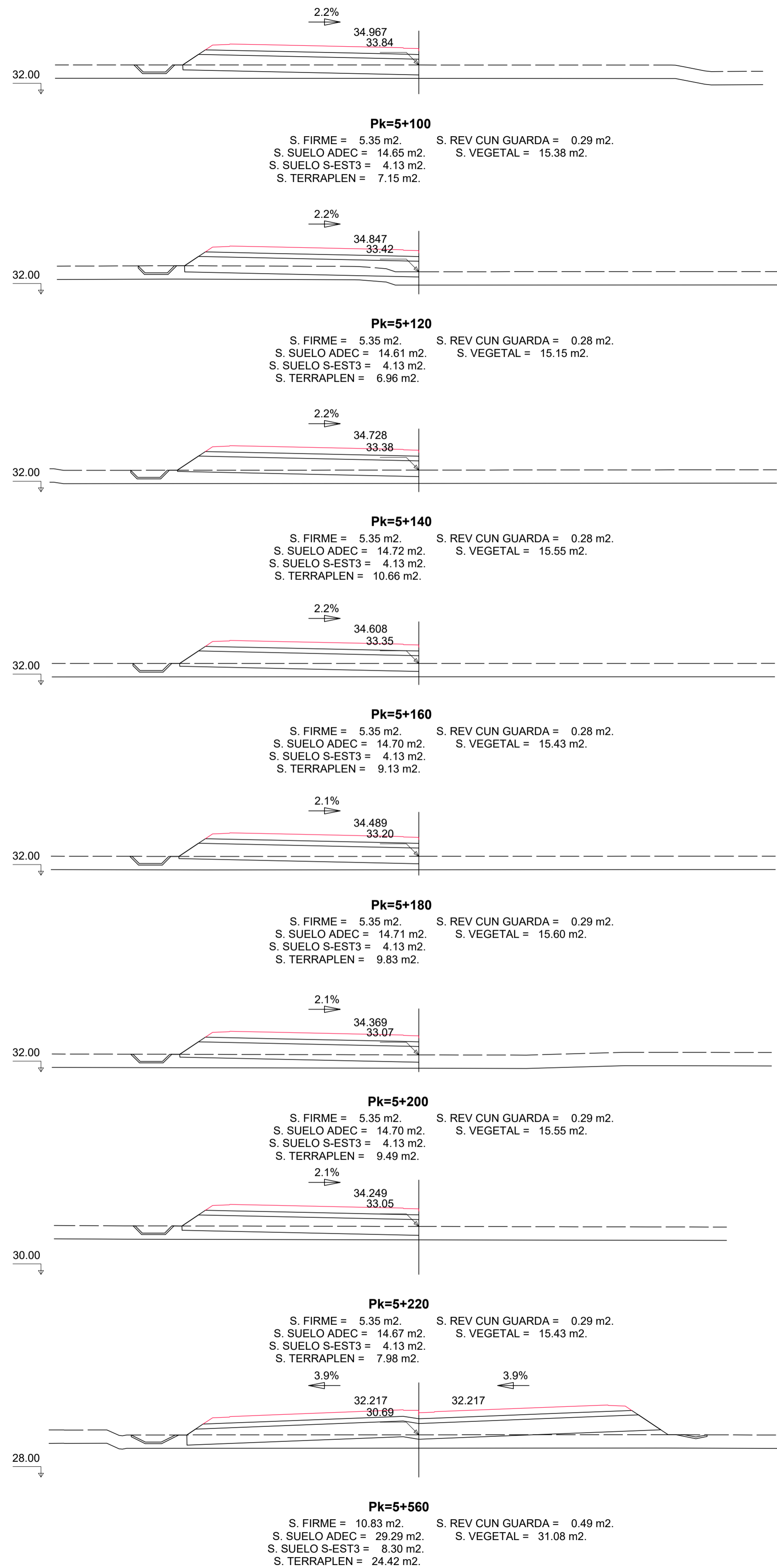
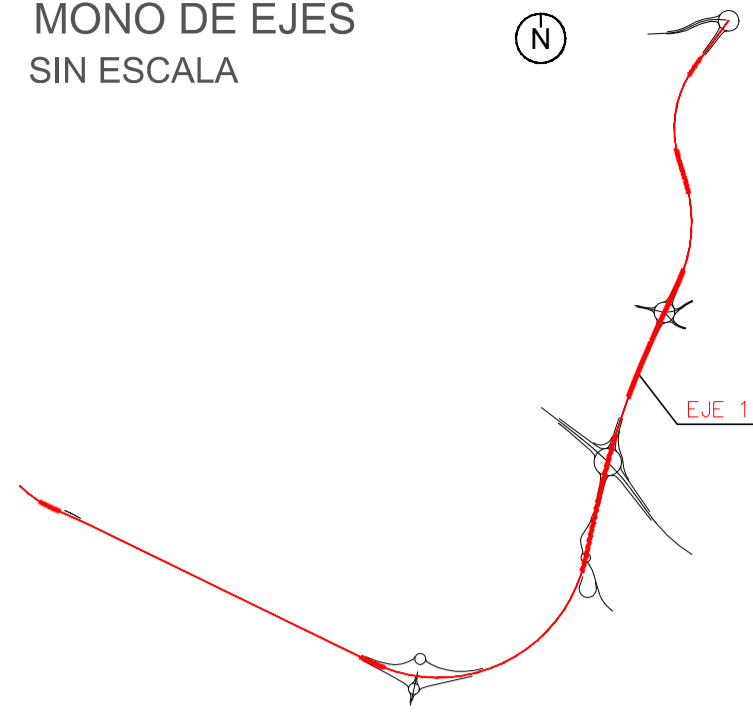

MONO DE EJES
SIN ESCALA

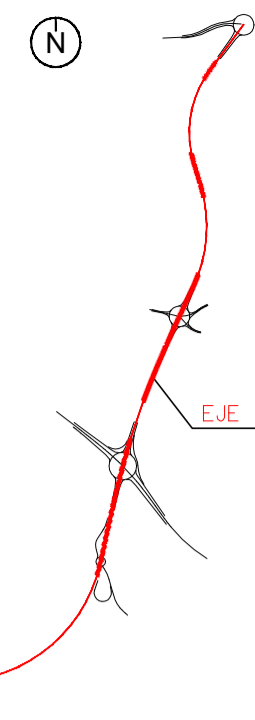

EJE 1 (HOJA 20 DE 22)

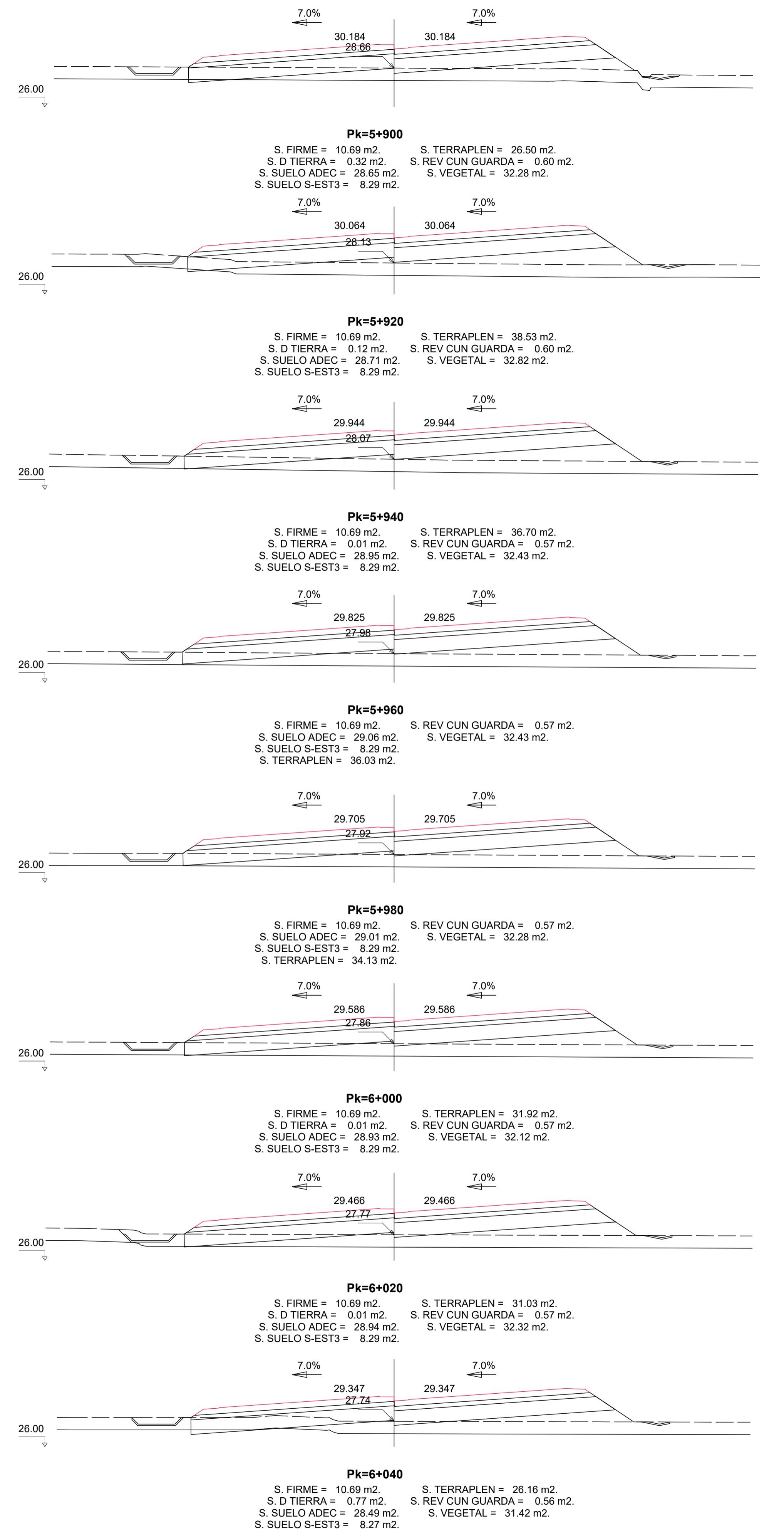
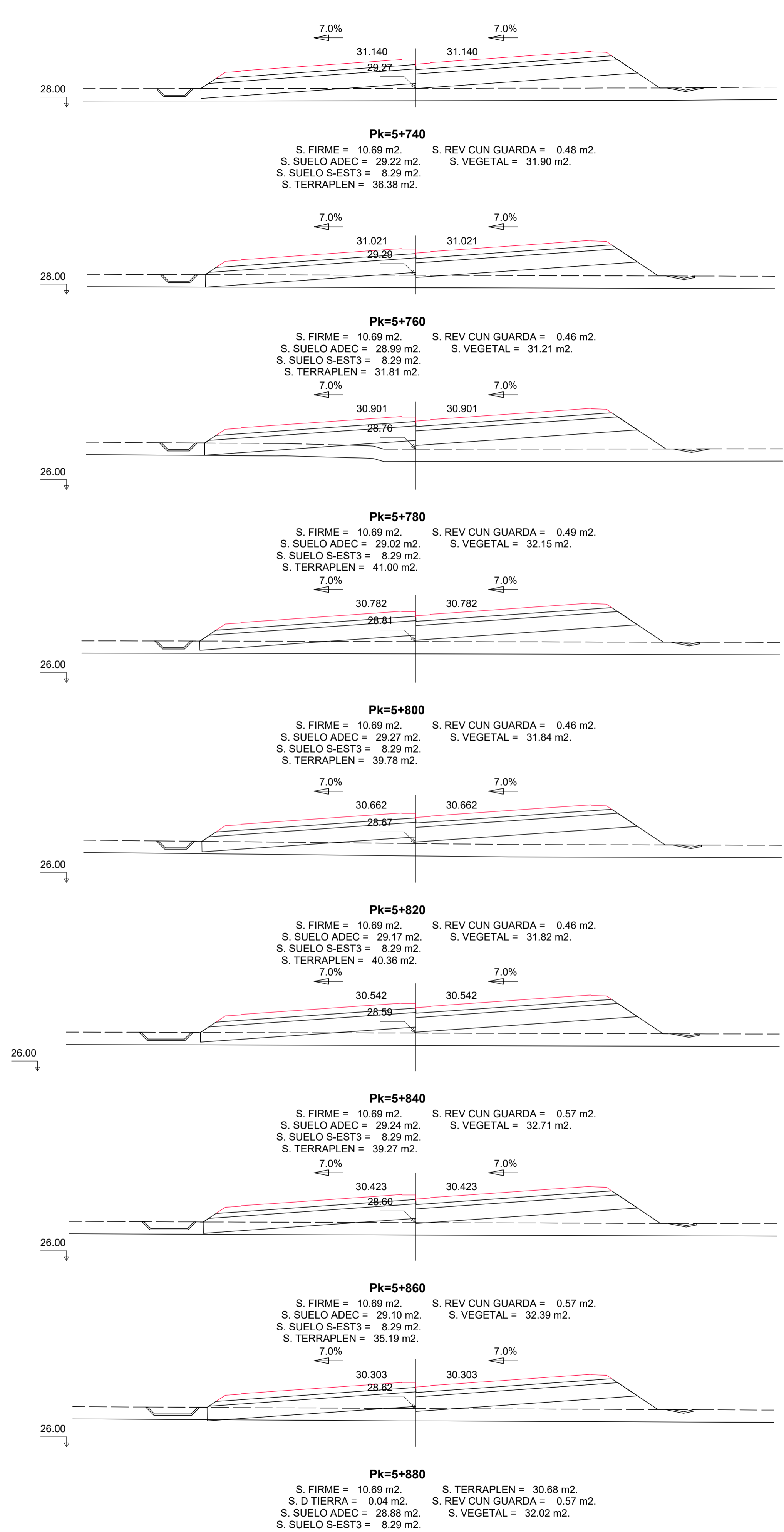

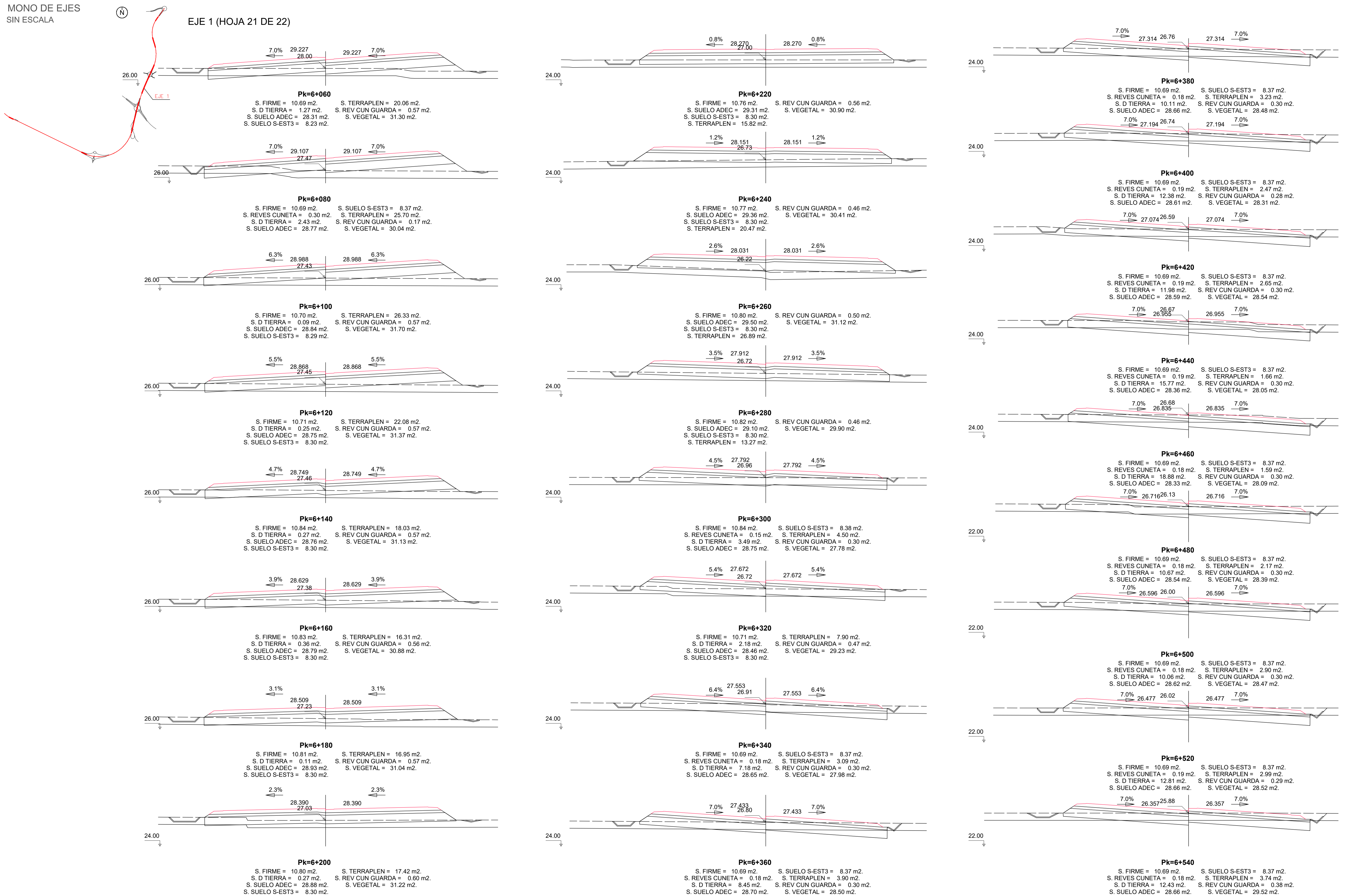

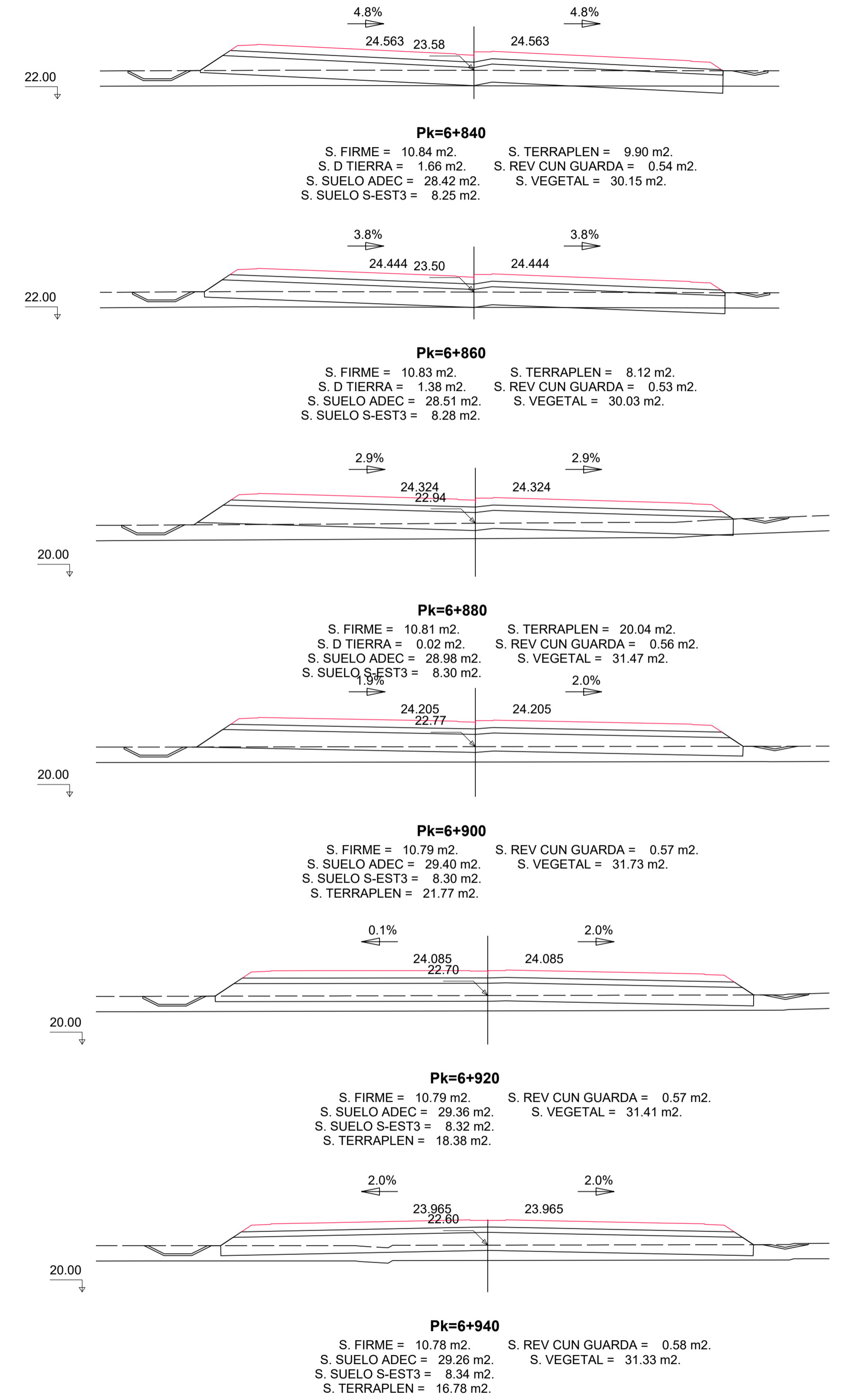
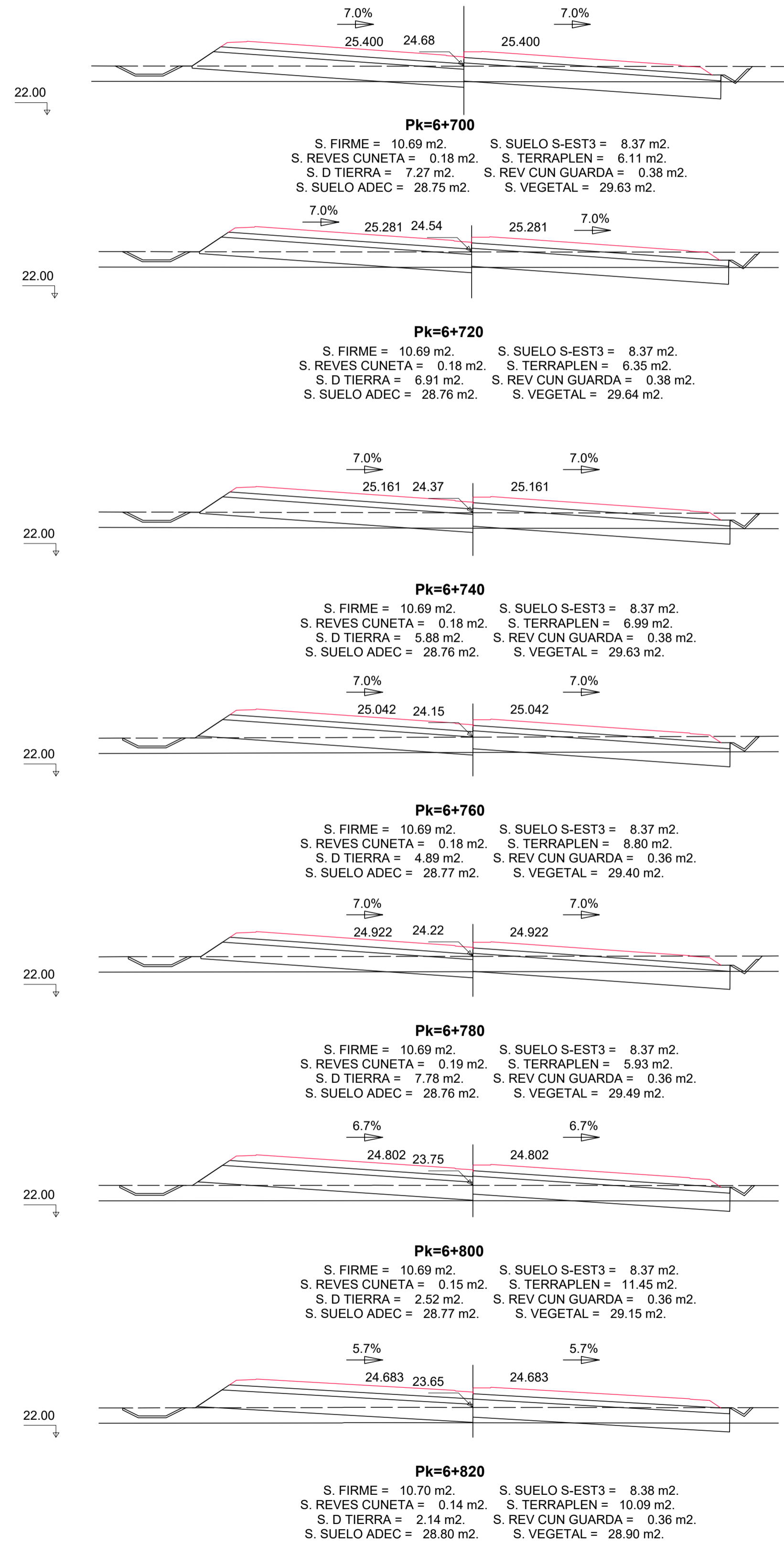
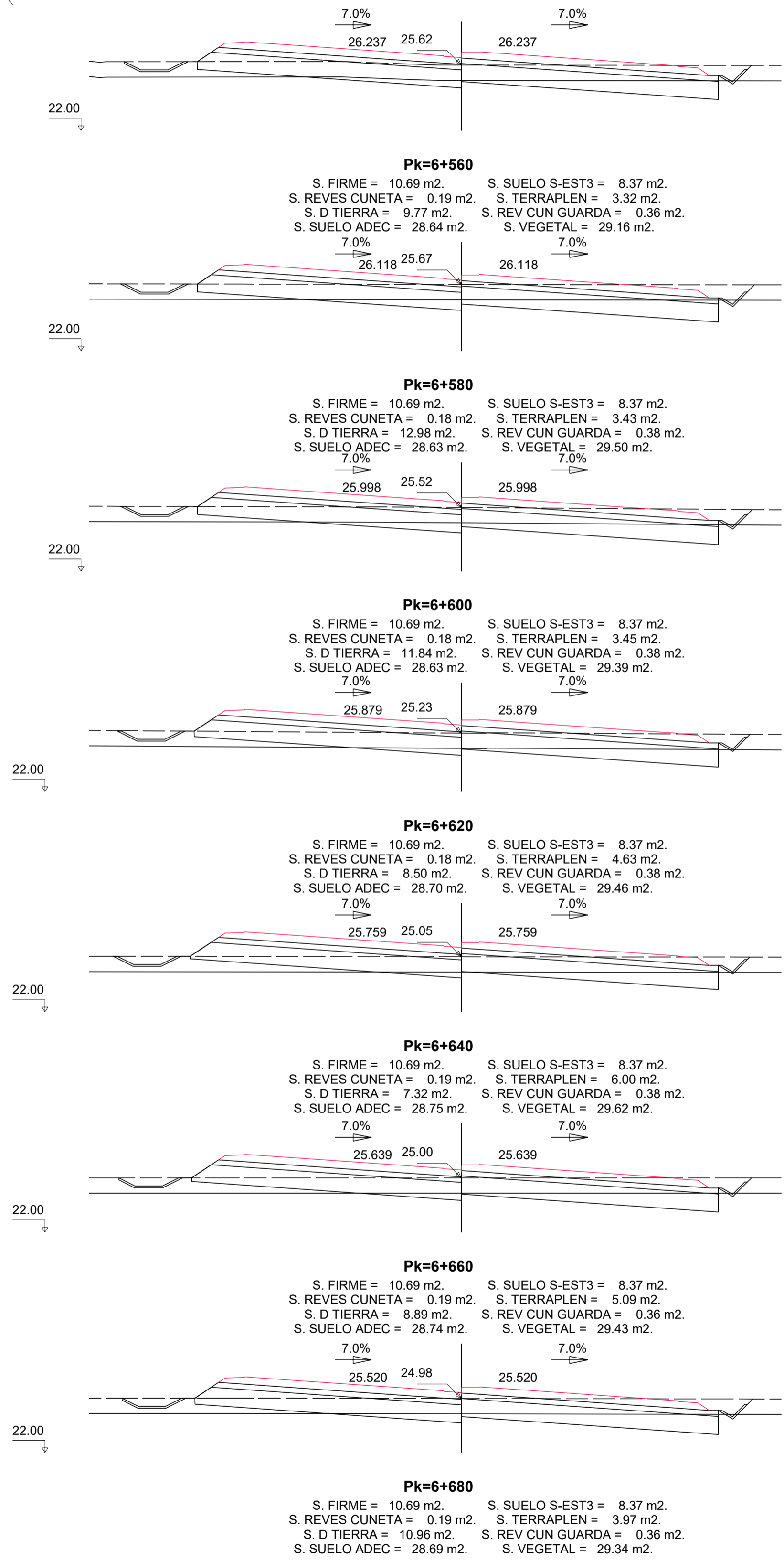
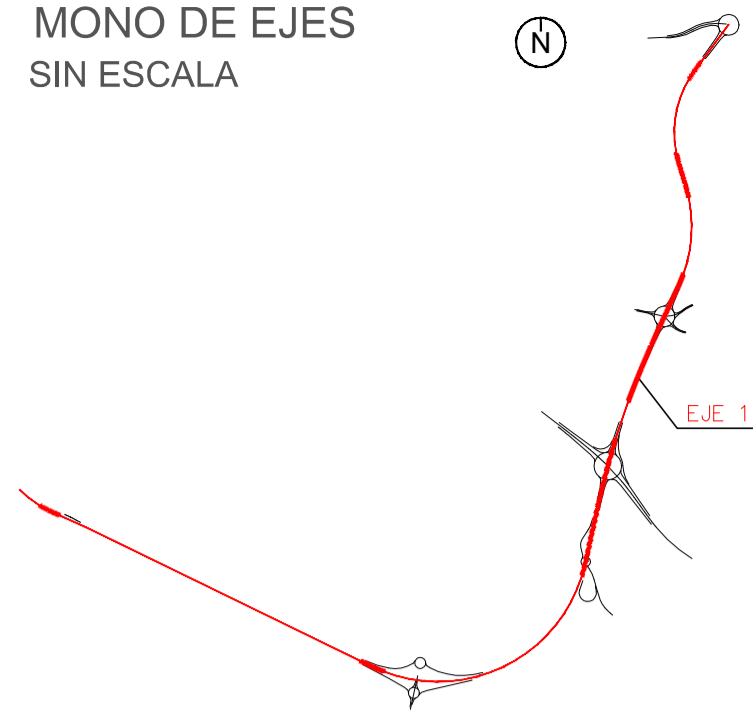

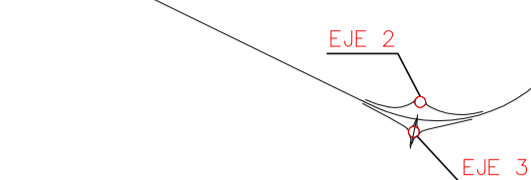

EJE 2

EJE 3

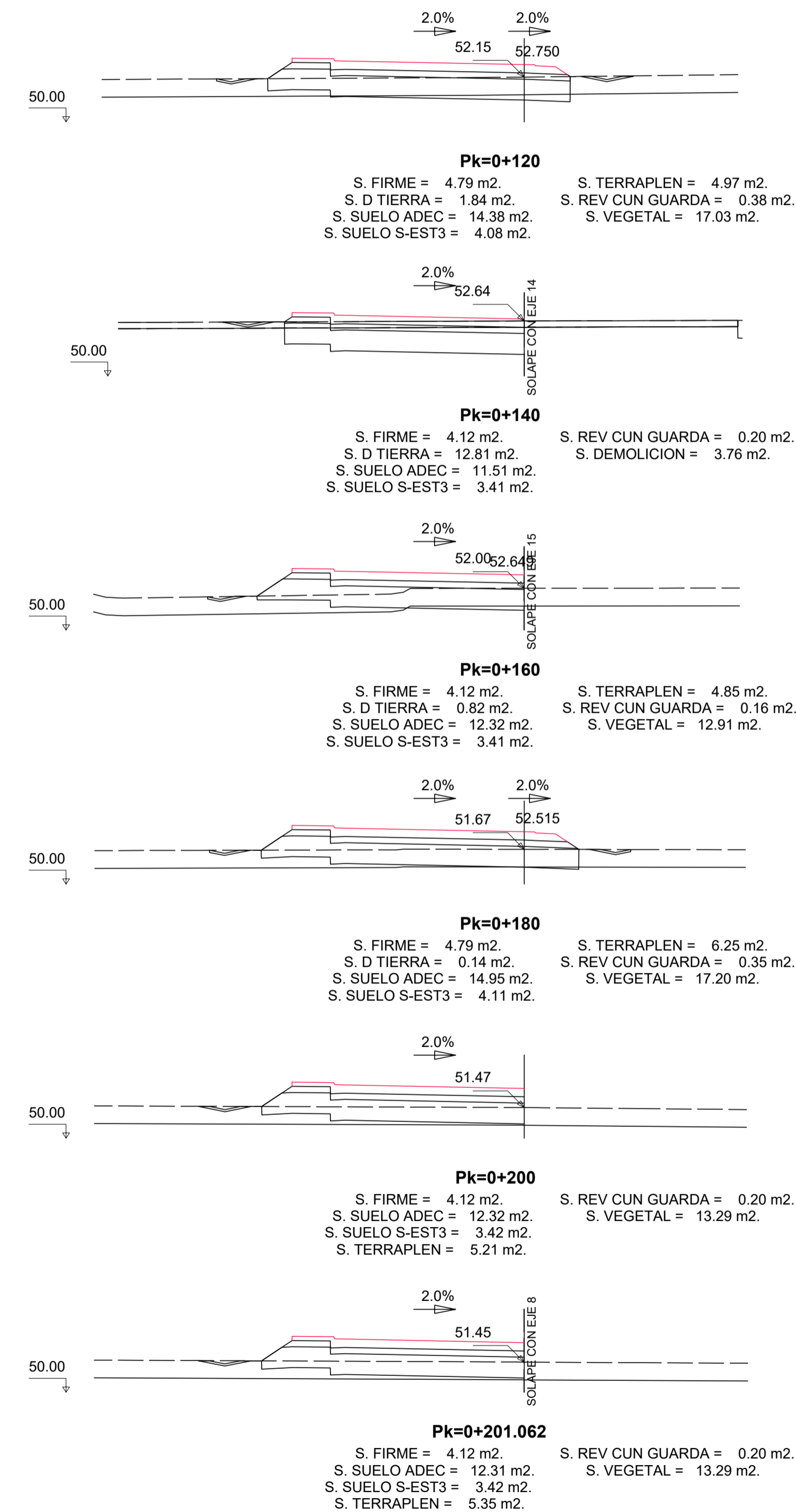
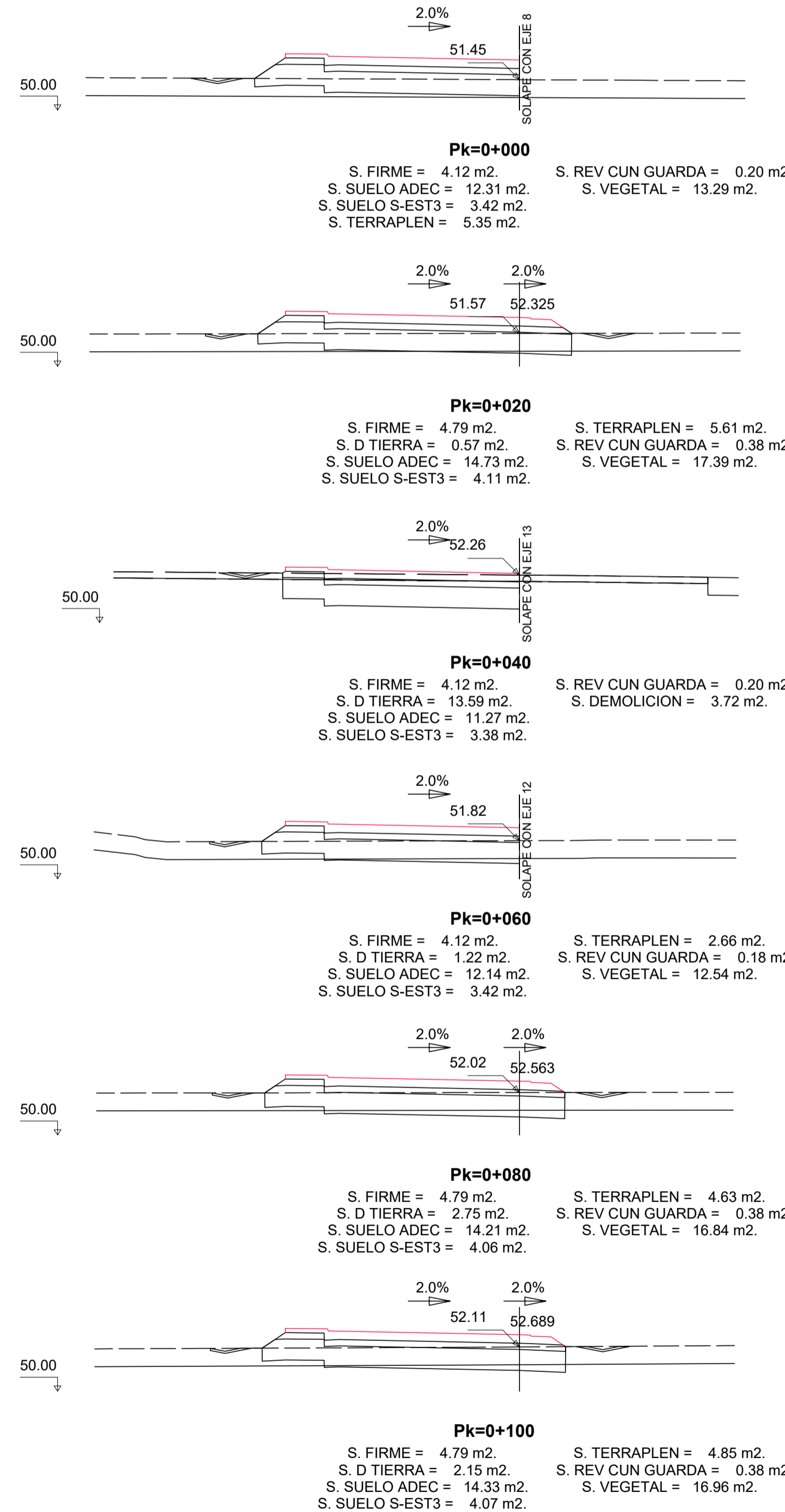
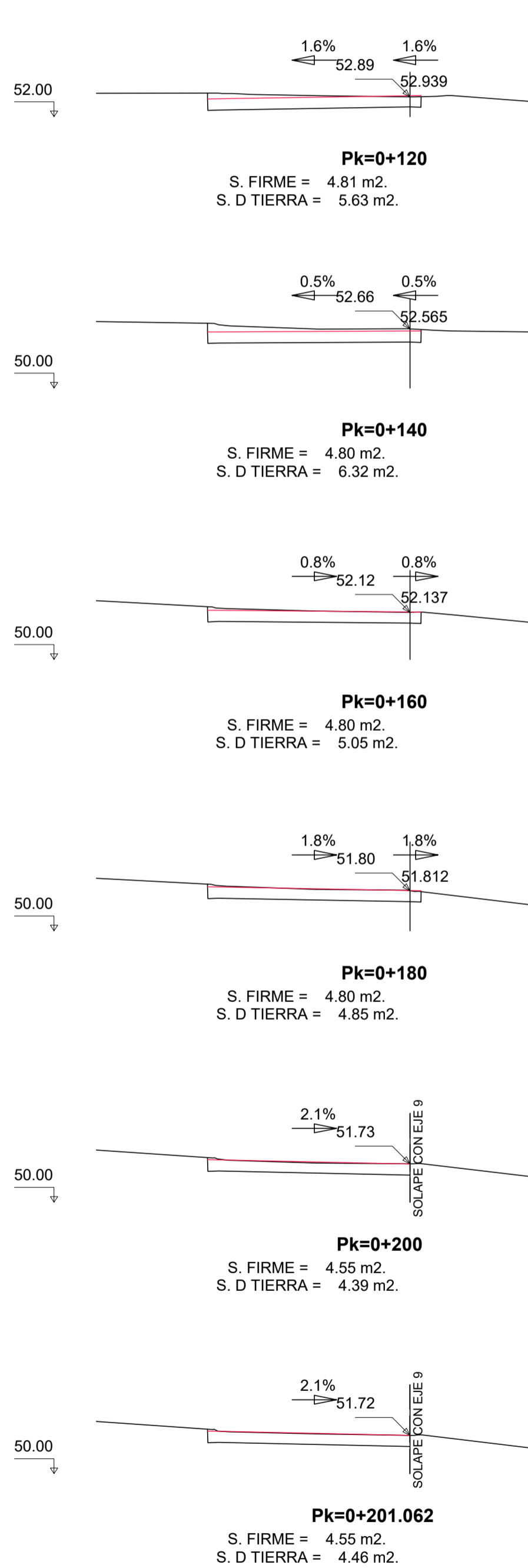
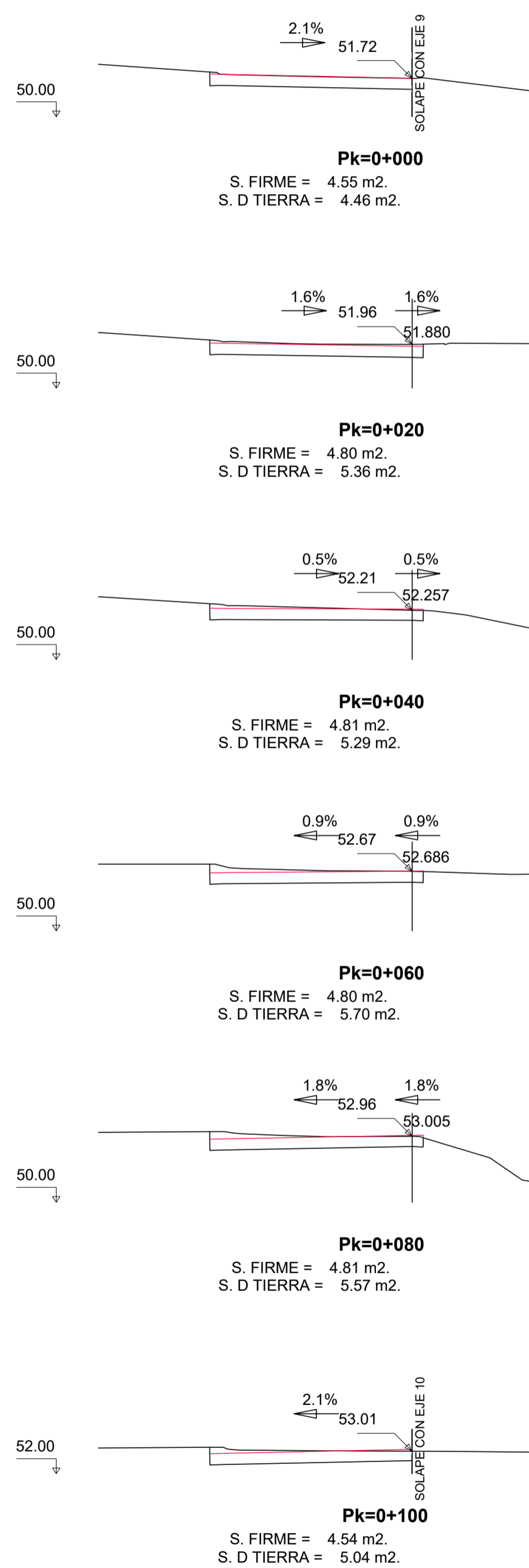

MONO DE EJES
SIN ESCALA

(N)

EJE 4 (HOJA 01 DE 03)

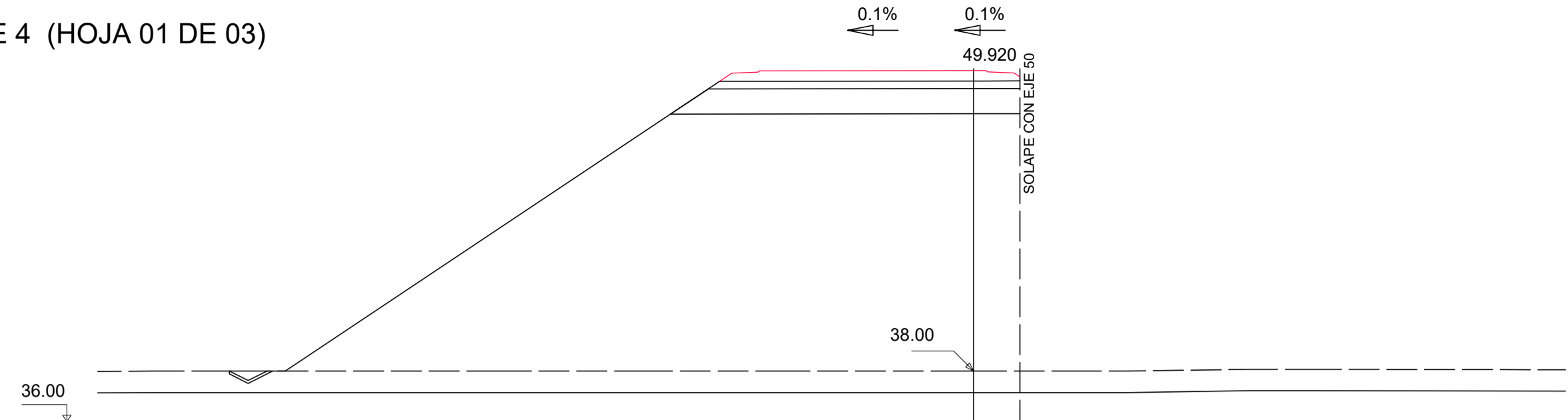
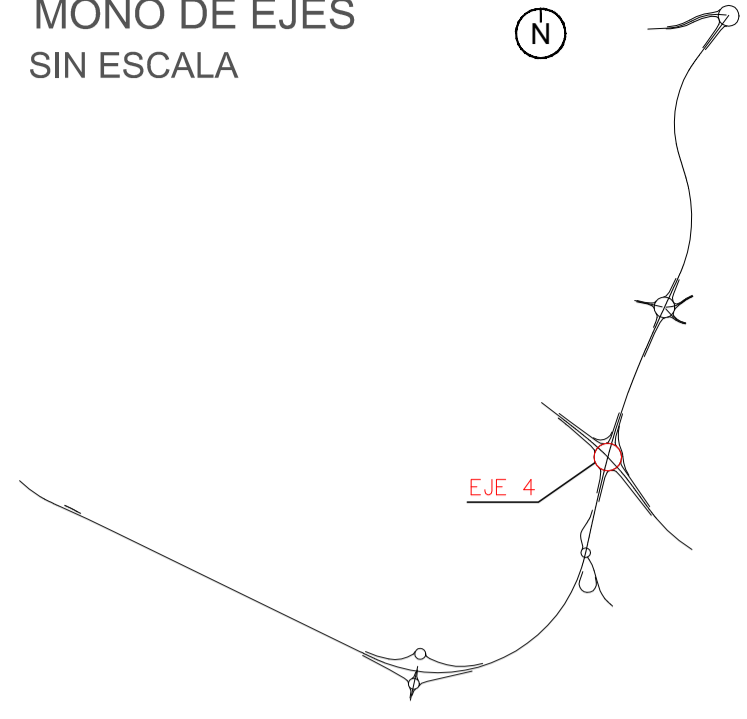

Pk=0+000
 S. FIRME = 4.58 m2.
 S. SUELO ADEC = 13.12 m2.
 S. SUELO S-EST3 = 3.64 m2.
 S. TERRAPLEN = 245.70 m2.
 S. REV CUN GUARDA = 0.18 m2.
 S. VEGETAL = 26.67 m2.

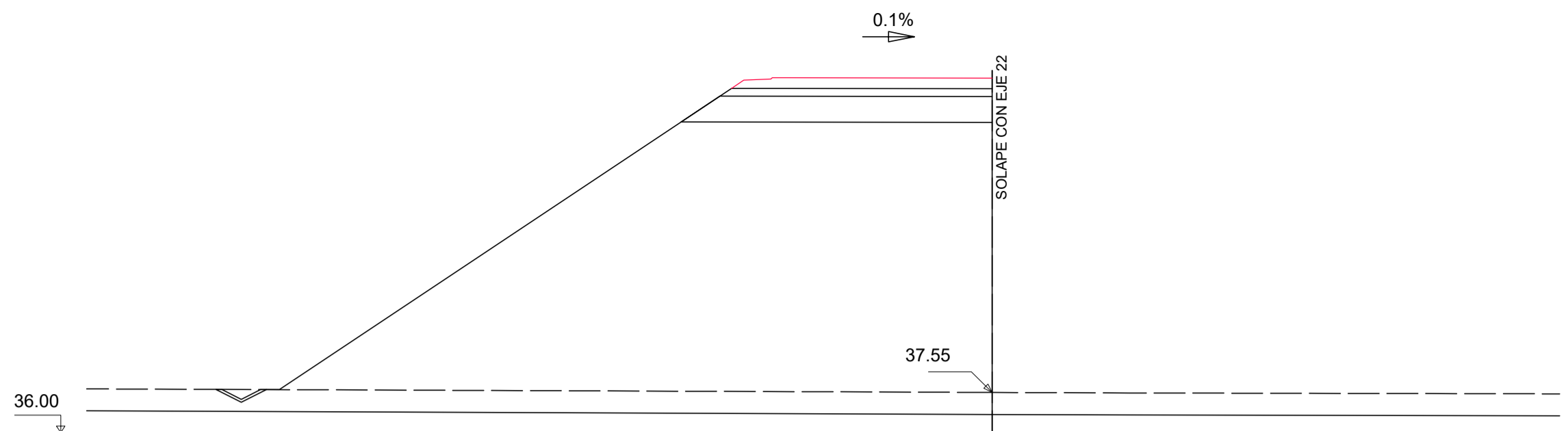

Pk=0+080
 S. FIRME = 3.94 m2.
 S. SUELO ADEC = 11.27 m2.
 S. SUELO S-EST3 = 3.09 m2.
 S. TERRAPLEN = 231.19 m2.
 S. REV CUN GUARDA = 0.19 m2.
 S. VEGETAL = 25.50 m2.

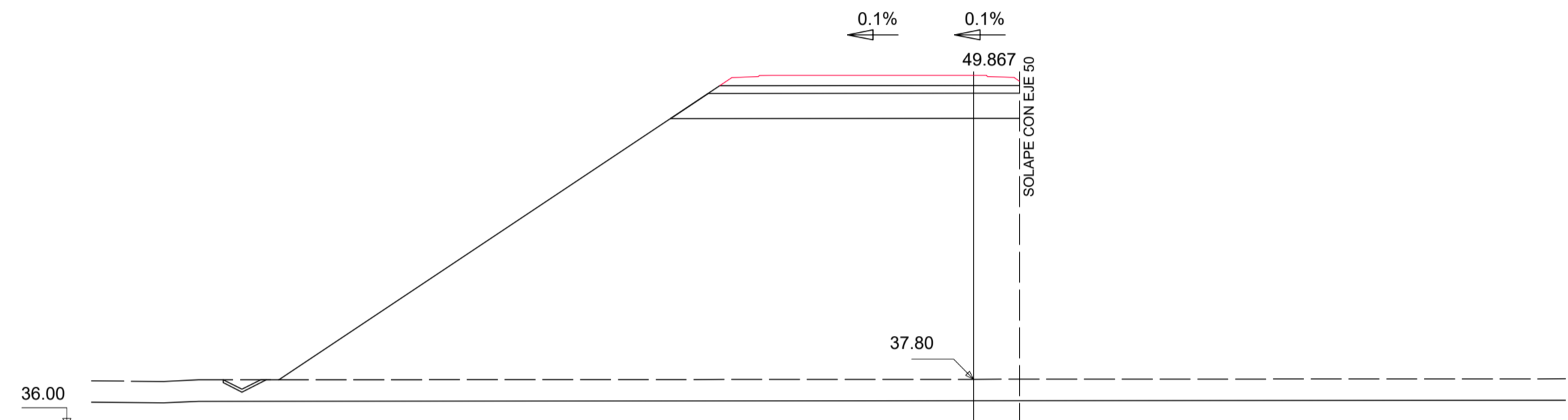

Pk=0+020
 S. FIRME = 4.57 m2.
 S. SUELO ADEC = 13.11 m2.
 S. SUELO S-EST3 = 3.64 m2.
 S. TERRAPLEN = 250.34 m2.
 S. REV CUN GUARDA = 0.18 m2.
 S. VEGETAL = 26.88 m2.

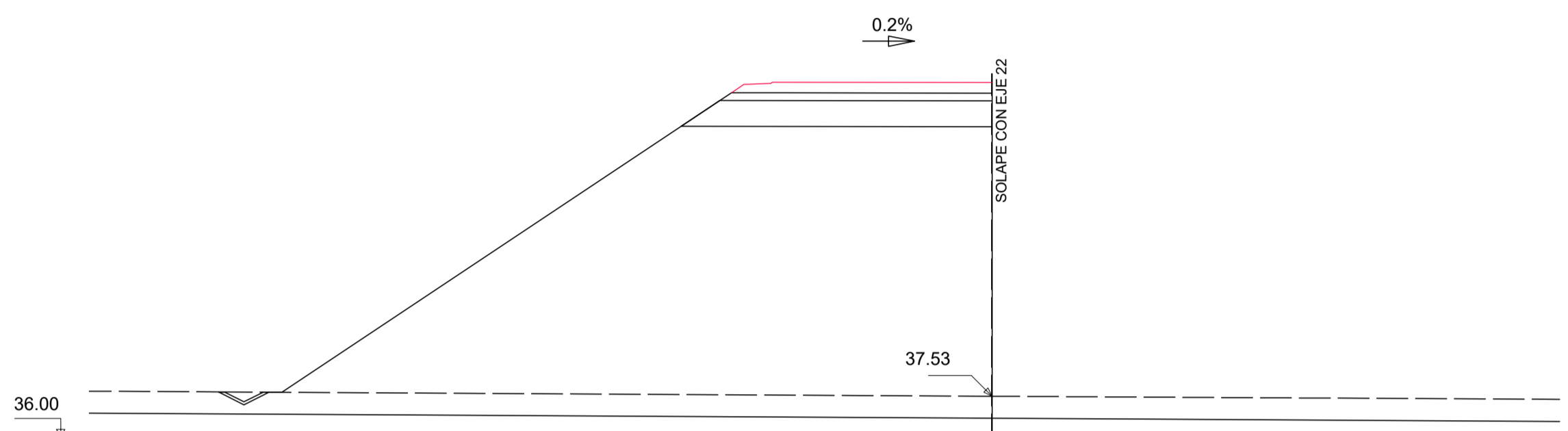

Pk=0+100
 S. FIRME = 3.93 m2.
 S. SUELO ADEC = 11.26 m2.
 S. SUELO S-EST3 = 3.09 m2.
 S. TERRAPLEN = 229.71 m2.
 S. REV CUN GUARDA = 0.19 m2.
 S. VEGETAL = 25.40 m2.

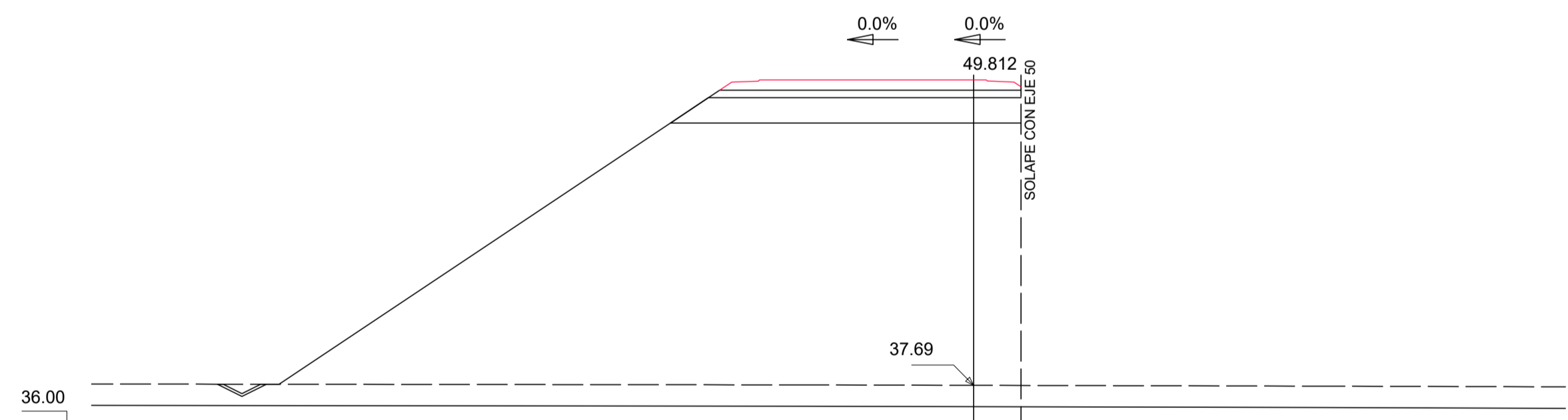

Pk=0+040
 S. FIRME = 4.58 m2.
 S. SUELO ADEC = 13.16 m2.
 S. SUELO S-EST3 = 3.65 m2.
 S. TERRAPLEN = 251.94 m2.
 S. REV CUN GUARDA = 0.19 m2.
 S. VEGETAL = 27.11 m2.

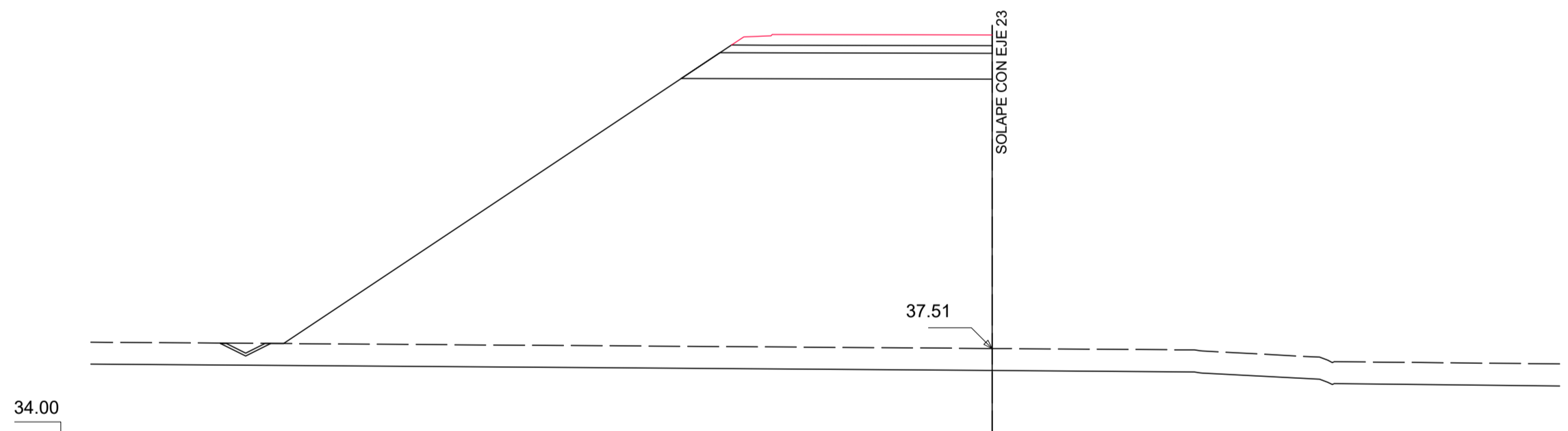

Pk=0+120
 S. FIRME = 3.93 m2.
 S. SUELO ADEC = 11.27 m2.
 S. SUELO S-EST3 = 3.09 m2.
 S. TERRAPLEN = 229.11 m2.
 S. REV CUN GUARDA = 0.19 m2.
 S. VEGETAL = 25.36 m2.

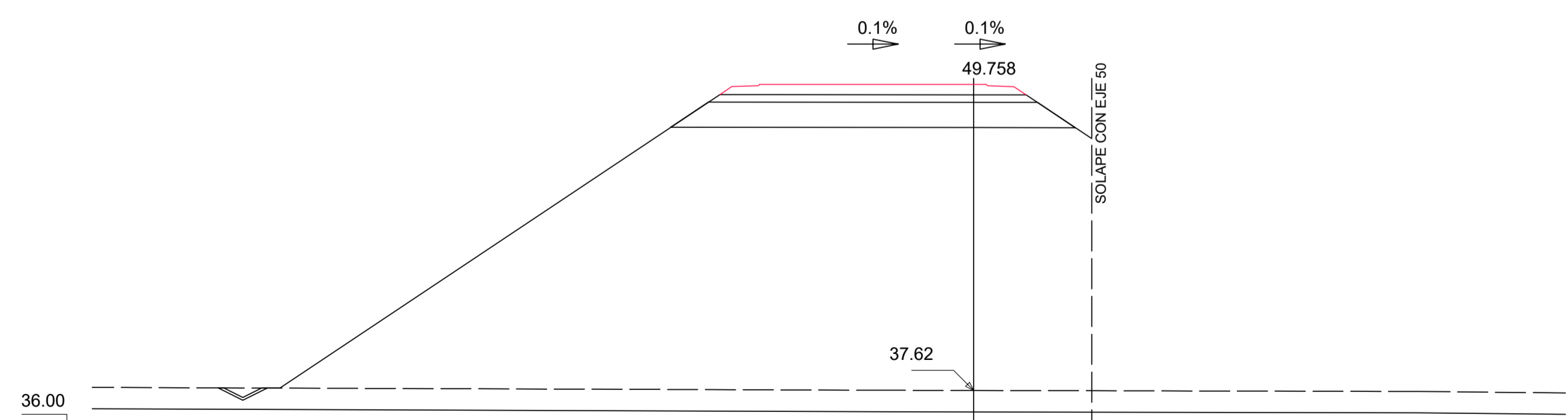

Pk=0+060
 S. FIRME = 4.60 m2.
 S. SUELO ADEC = 14.56 m2.
 S. SUELO S-EST3 = 3.78 m2.
 S. TERRAPLEN = 283.74 m2.
 S. REV CUN GUARDA = 0.19 m2.
 S. VEGETAL = 29.48 m2.

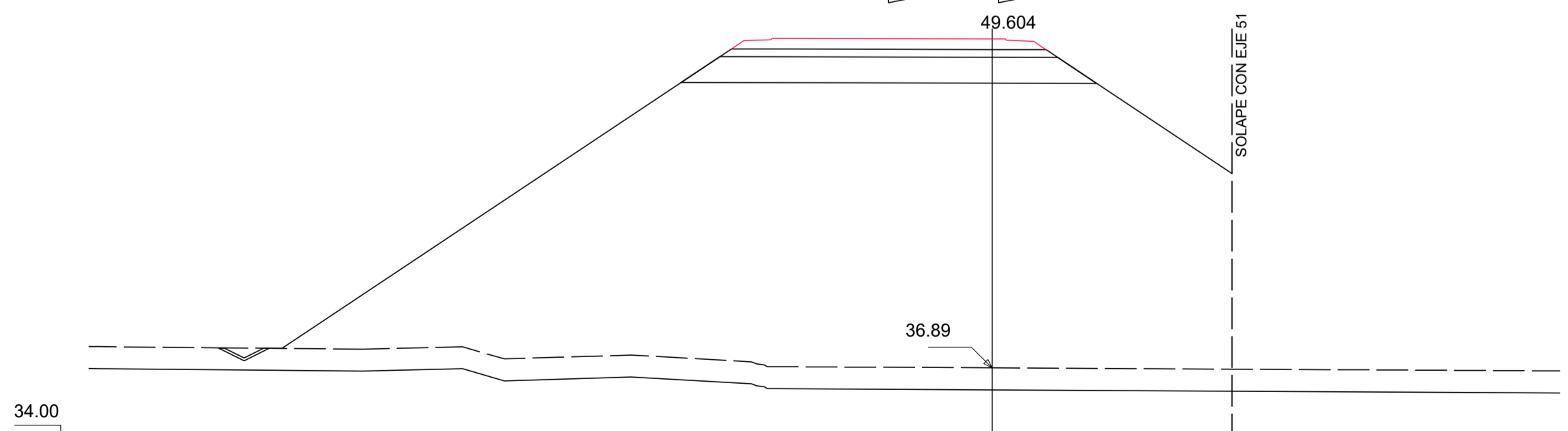

Pk=0+140
 S. FIRME = 4.60 m2.
 S. SUELO ADEC = 14.56 m2.
 S. SUELO S-EST3 = 3.78 m2.
 S. TERRAPLEN = 339.02 m2.
 S. REV CUN GUARDA = 0.19 m2.
 S. VEGETAL = 33.30 m2.

MONO DE EJES
SIN ESCALA

EJE 4 (HOJA 02 DE 03)

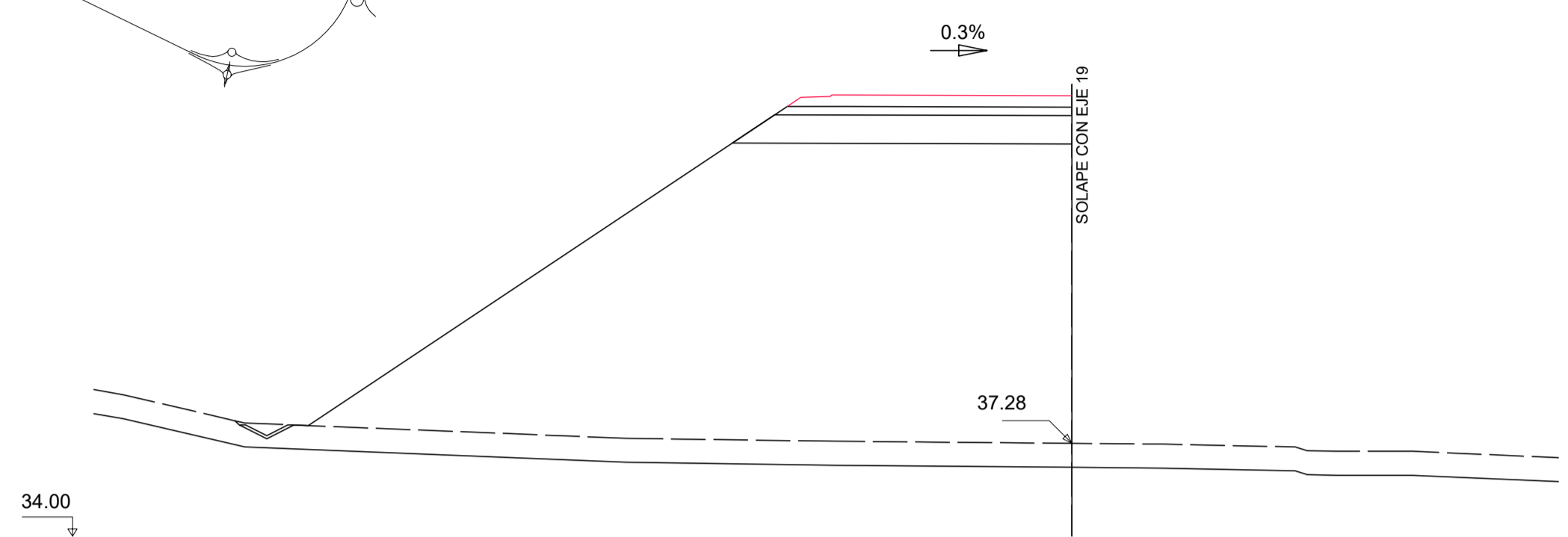

Pk=0+160
S. FIRME = 3.93 m².
S. SUELO ADEC = 11.27 m².
S. SUELO S-EST3 = 3.09 m².
S. TERRAPLEN = 230.99 m².
S. REV CUN GUARDA = 0.19 m².
S. VEGETAL = 25.17 m².

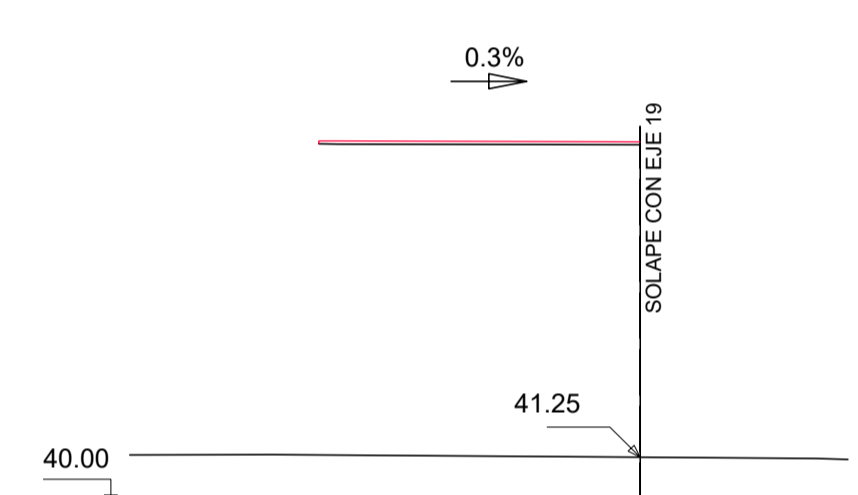

Pk=0+180
S. FIRME = 0.68 m².

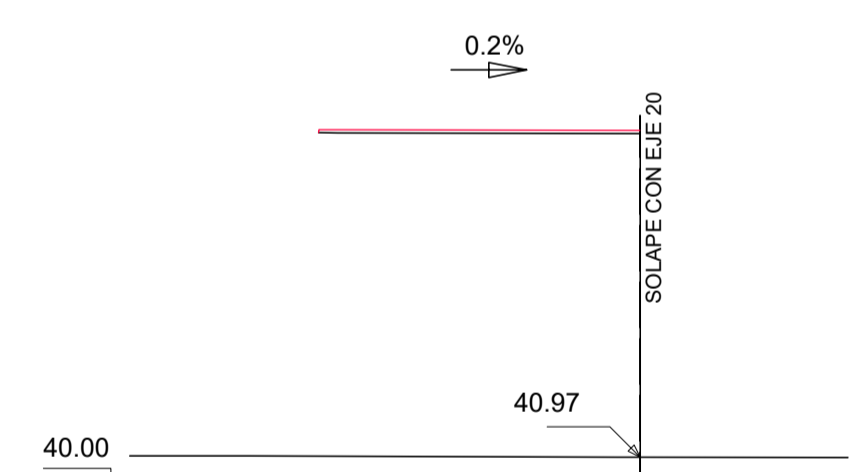

Pk=0+200
S. FIRME = 0.68 m².

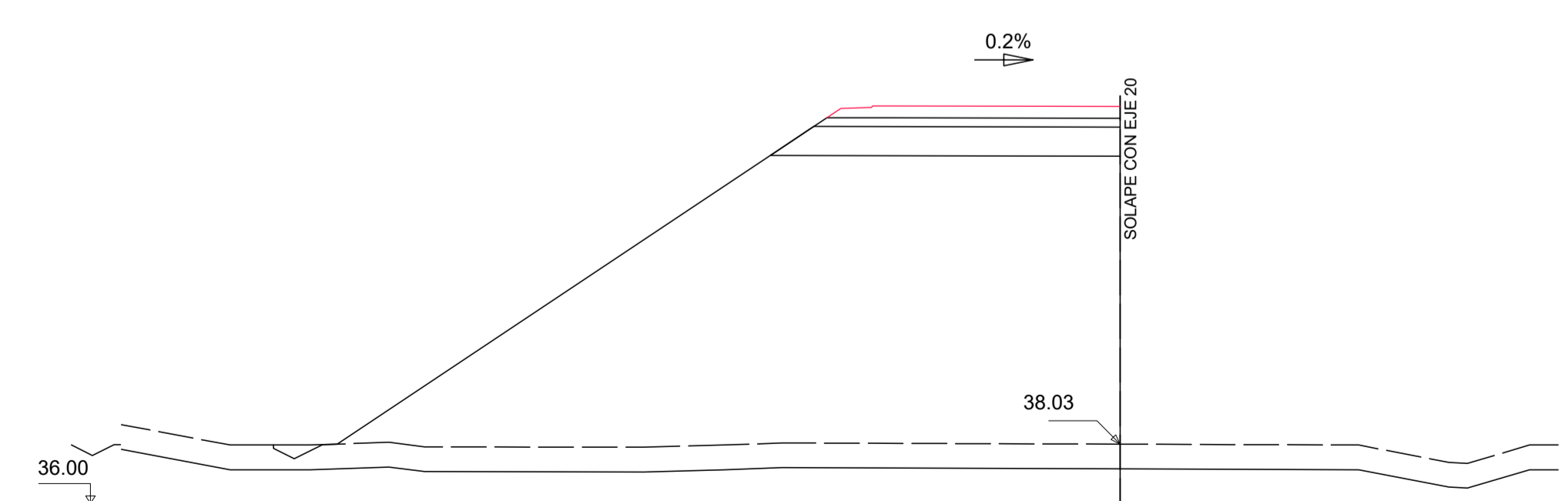

Pk=0+220
S. FIRME = 3.93 m².
S. SUELO ADEC = 11.27 m².
S. SUELO S-EST3 = 3.09 m².
S. TERRAPLEN = 217.86 m².
S. REV CUN GUARDA = 0.18 m².
S. VEGETAL = 24.72 m².

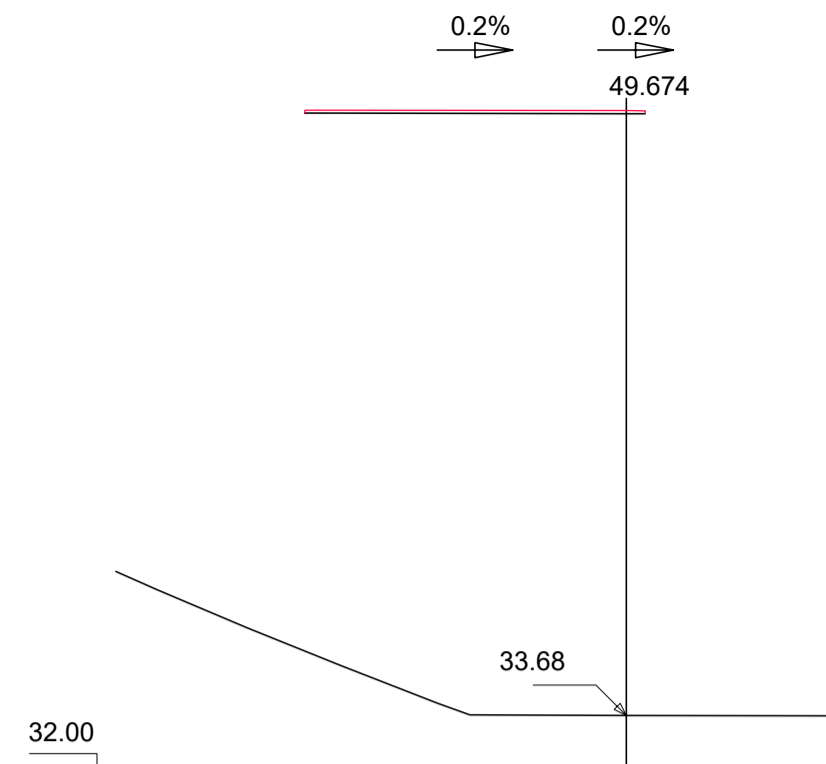

Pk=0+240
S. FIRME = 0.72 m².

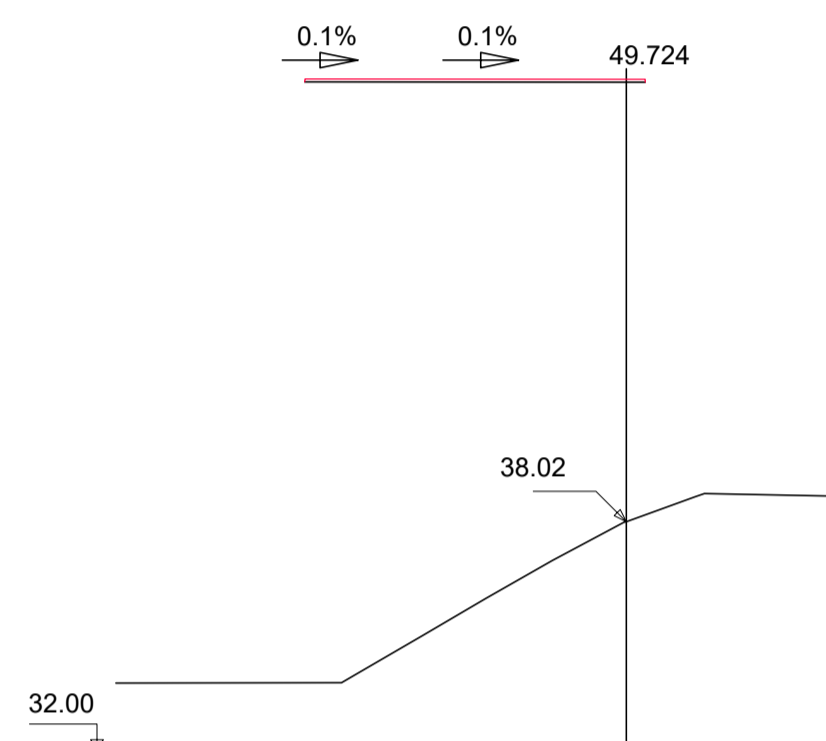

Pk=0+260
S. FIRME = 0.72 m².

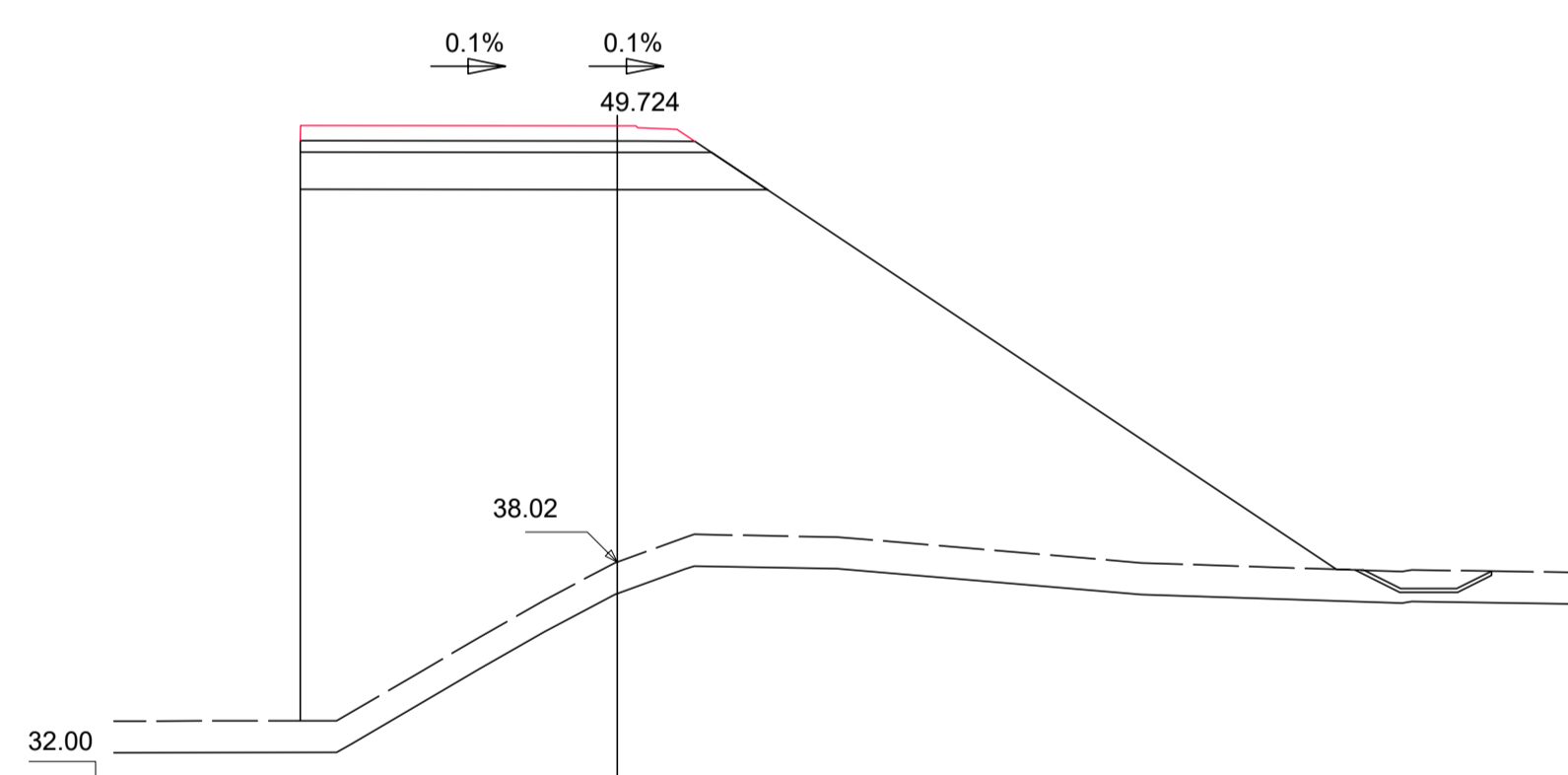

Pk=0+260
S. FIRME = 4.15 m².
S. SUELO ADEC = 11.79 m².
S. SUELO S-EST3 = 3.24 m².
S. TERRAPLEN = 239.98 m².
S. REV CUN GUARDA = 0.38 m².
S. VEGETAL = 27.18 m².

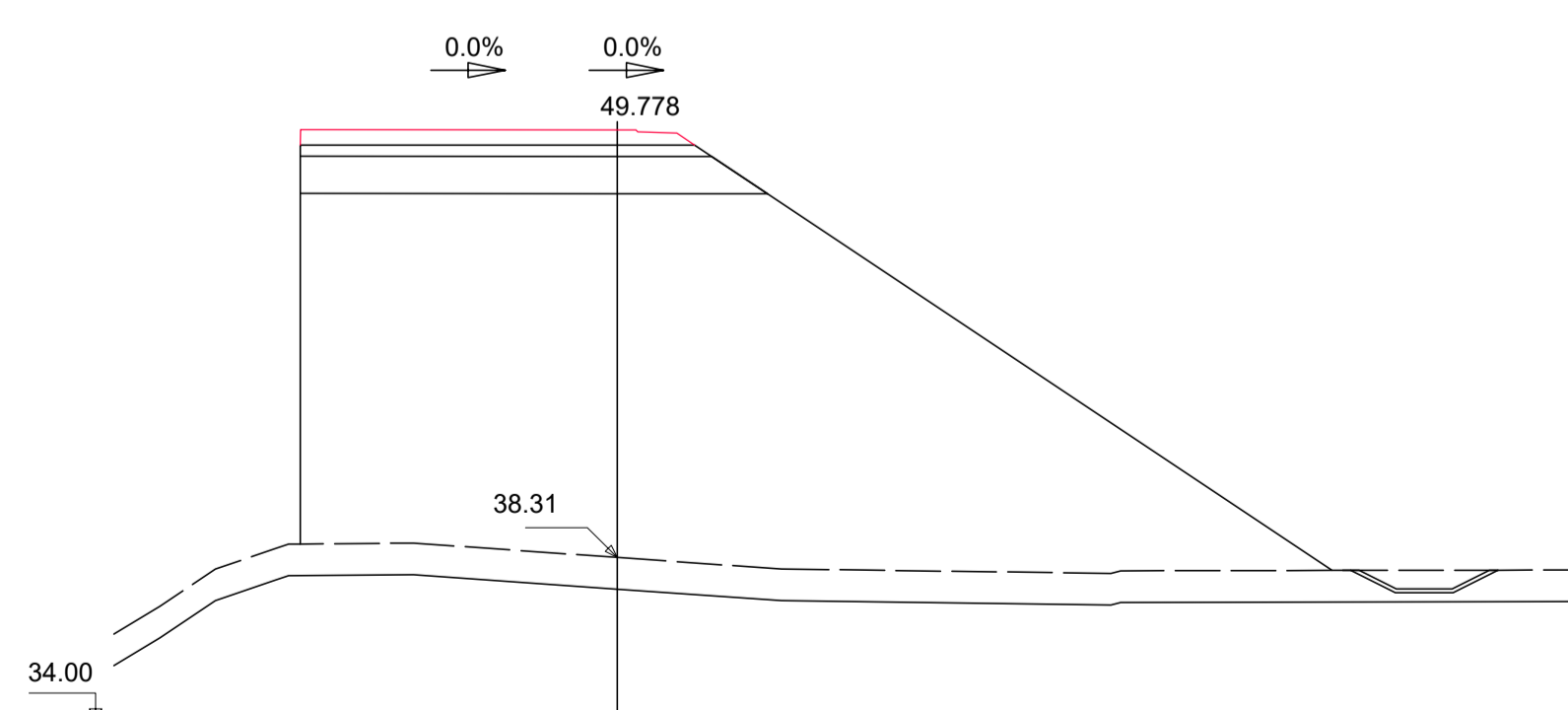

Pk=0+280
S. FIRME = 4.14 m².
S. SUELO ADEC = 11.79 m².
S. SUELO S-EST3 = 3.24 m².
S. TERRAPLEN = 223.16 m².
S. REV CUN GUARDA = 0.40 m².
S. VEGETAL = 27.33 m².

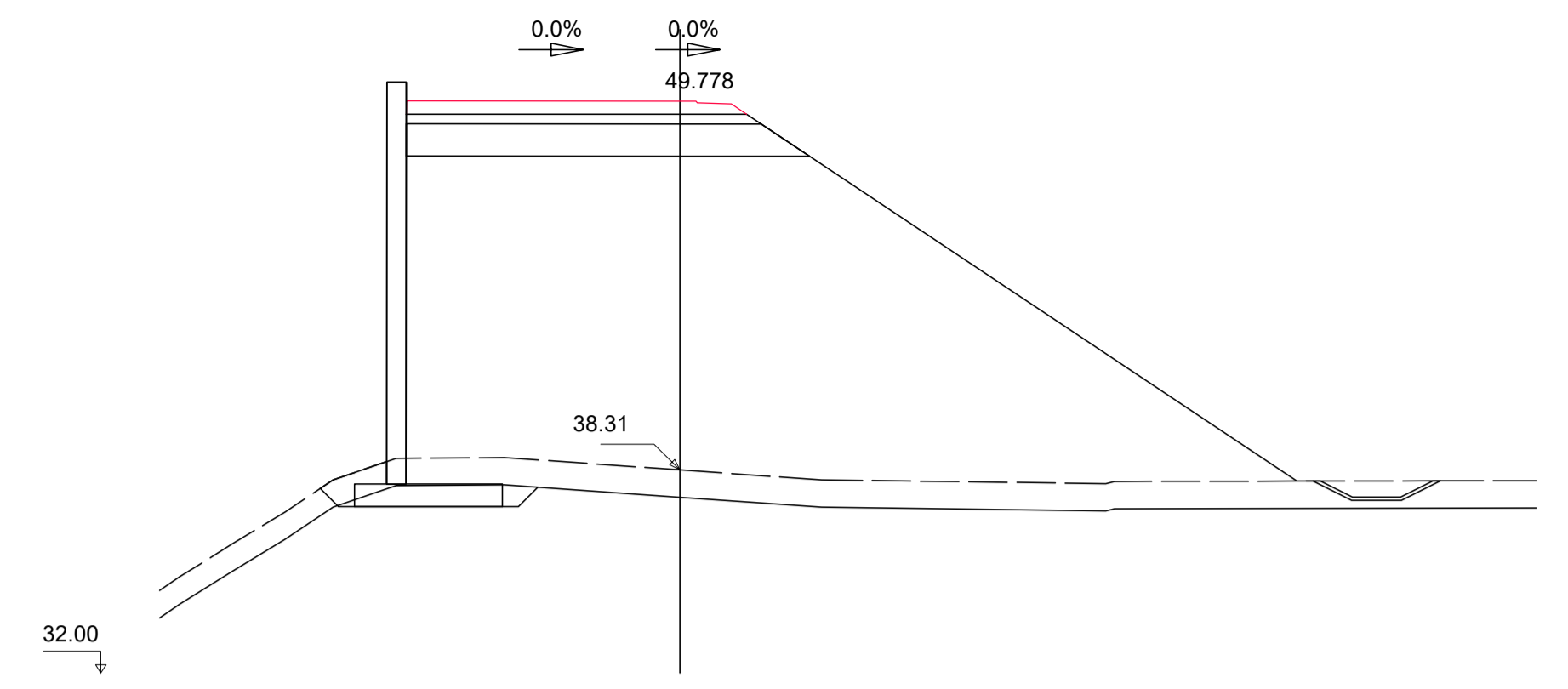

Pk=0+280
S. FIRME = 4.14 m².
S. SUELO ADEC = 11.79 m².
S. SUELO S-EST3 = 3.24 m².
S. TERRAPLEN = 223.10 m².
S. REV CUN GUARDA = 0.40 m².
S. ZAPATA MUROS = 3.22 m².
S. VEGETAL = 29.38 m².
S. RELL ZAP MURO = 1.80 m².
S. MUROS = 7.51 m².

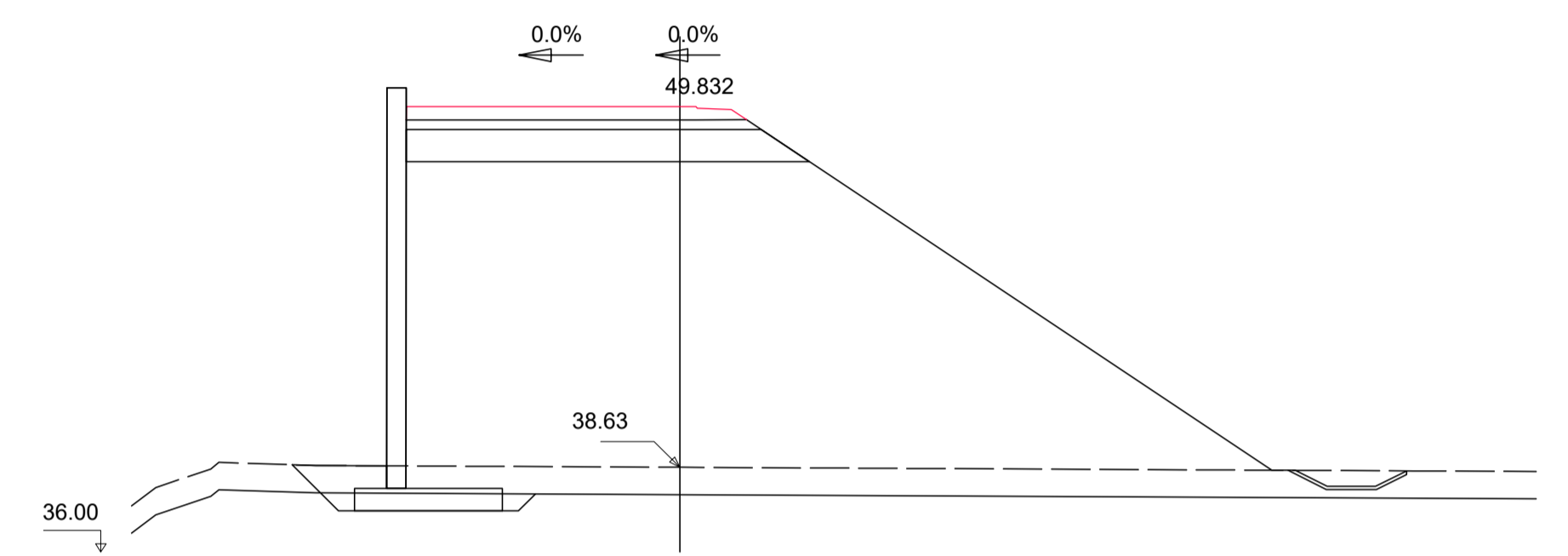

Pk=0+300
S. FIRME = 4.14 m².
S. SUELO ADEC = 11.78 m².
S. SUELO S-EST3 = 3.24 m².
S. TERRAPLEN = 211.63 m².
S. REV CUN GUARDA = 0.38 m².
S. ZAPATA MUROS = 3.22 m².
S. VEGETAL = 29.07 m².
S. RELL ZAP MURO = 2.81 m².
S. MUROS = 7.47 m².

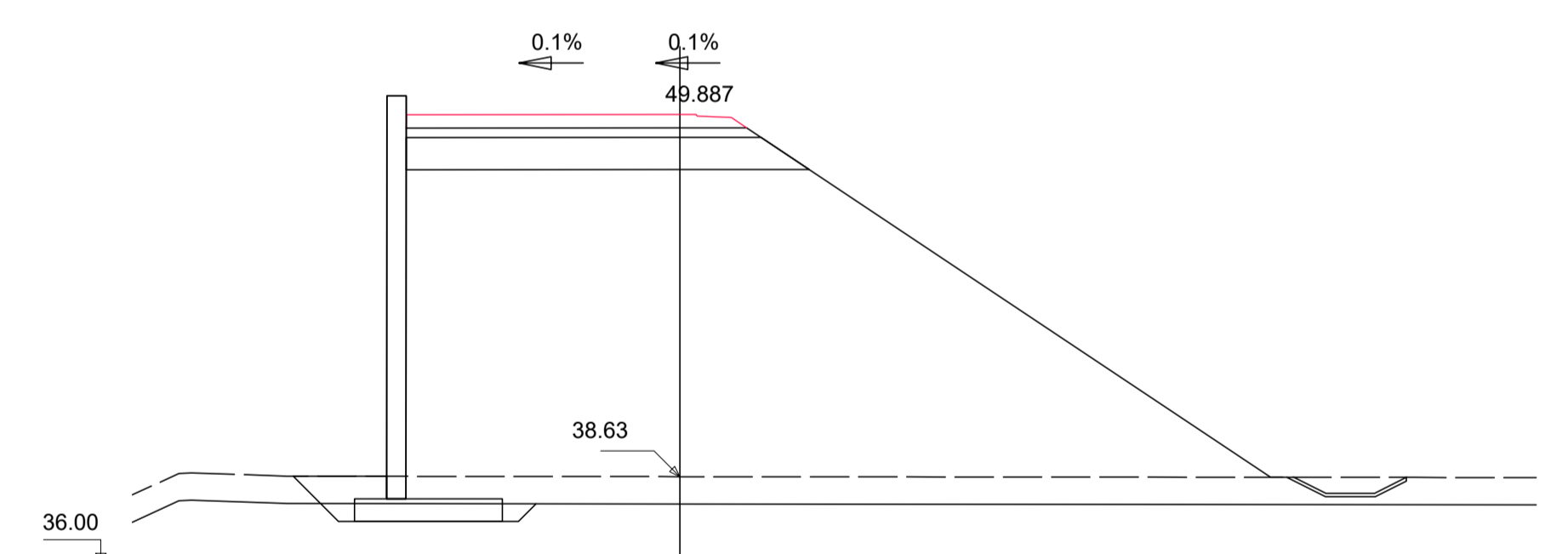

Pk=0+320
S. FIRME = 4.14 m².
S. SUELO ADEC = 11.78 m².
S. SUELO S-EST3 = 3.24 m².
S. TERRAPLEN = 212.44 m².
S. REV CUN GUARDA = 0.39 m².
S. ZAPATA MUROS = 3.22 m².
S. VEGETAL = 29.06 m².
S. RELL ZAP MURO = 2.81 m².
S. MUROS = 7.52 m².

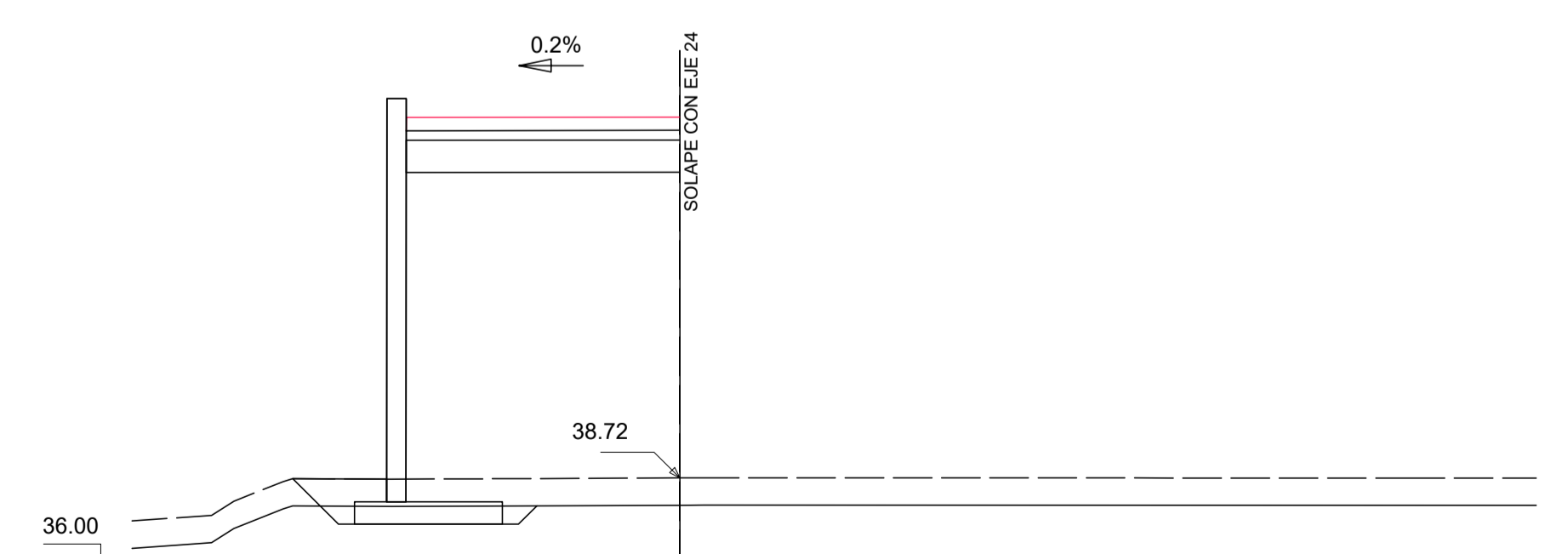

Pk=0+340
S. FIRME = 3.48 m².
S. SUELO ADEC = 8.50 m².
S. SUELO S-EST3 = 2.55 m².
S. TERRAPLEN = 87.77 m².
S. ZAPATA MUROS = 3.22 m².
S. VEGETAL = 9.86 m².
S. RELL ZAP MURO = 2.85 m².
S. MUROS = 7.52 m².

MONO DE EJES
SIN ESCALA

EJE 4 (HOJA 03 DE 03)

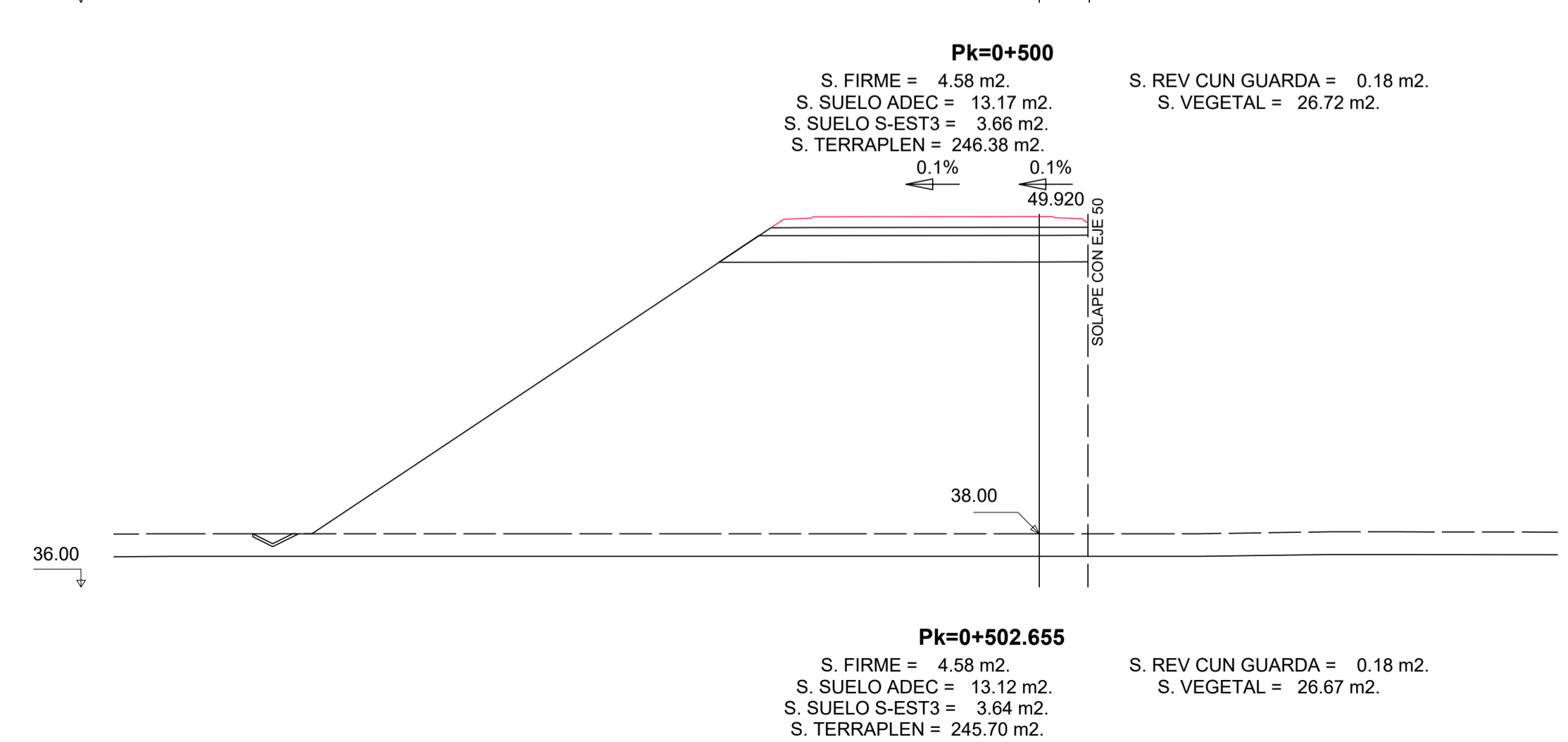
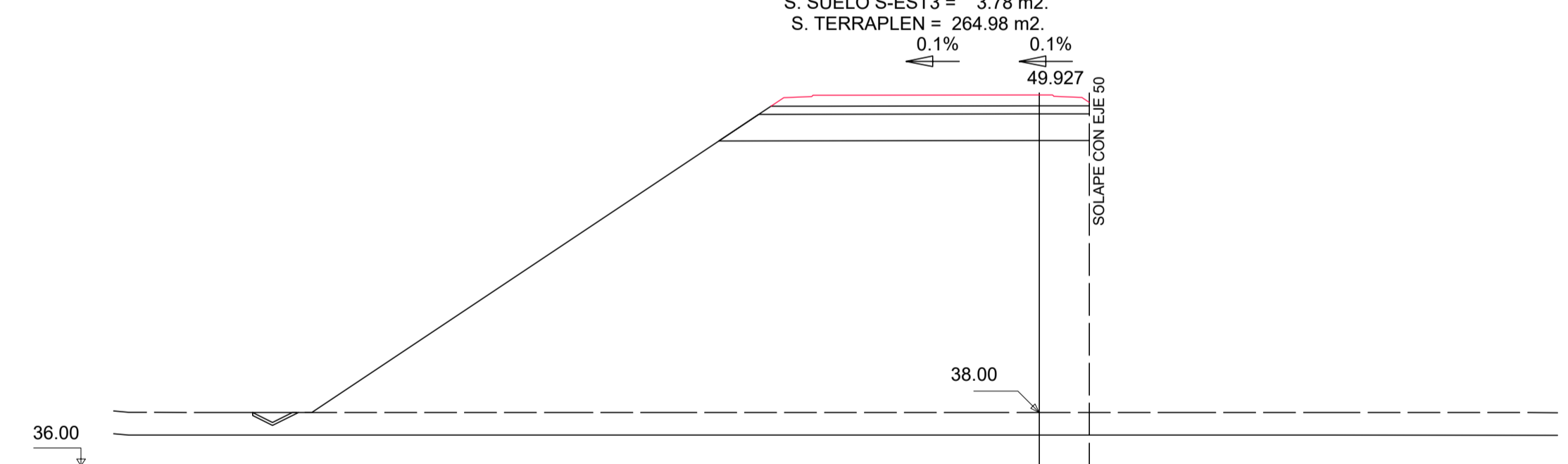
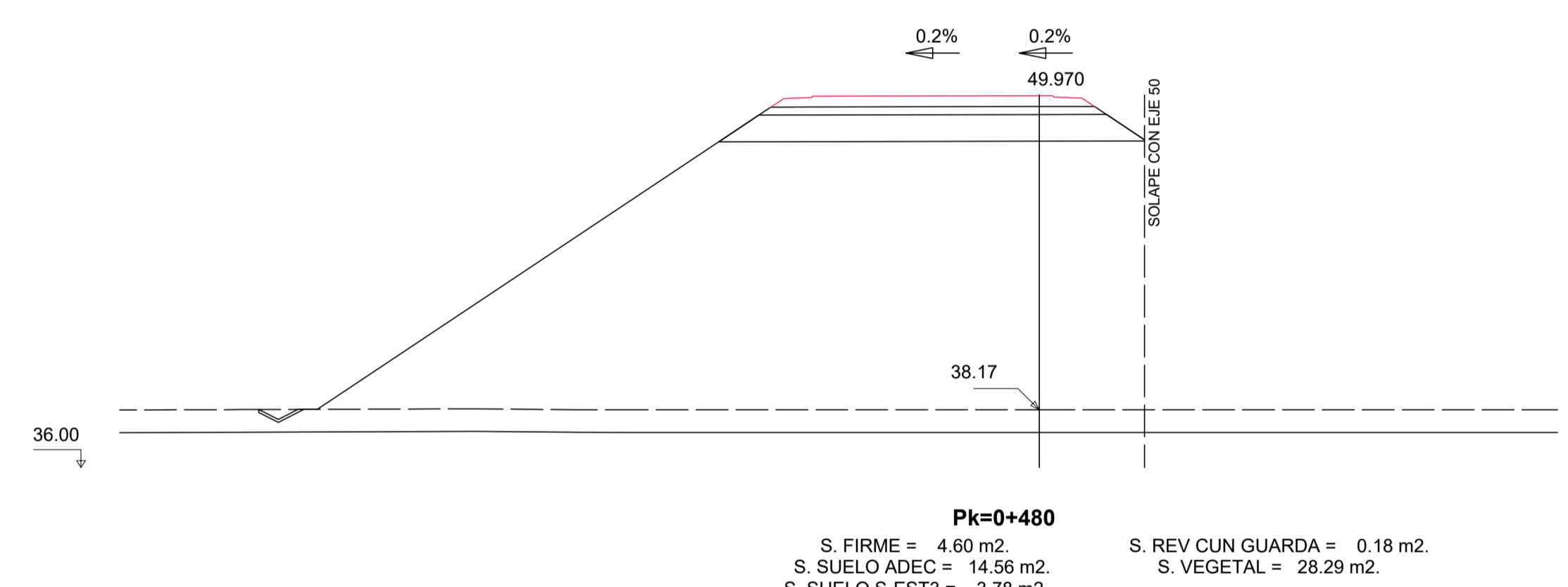
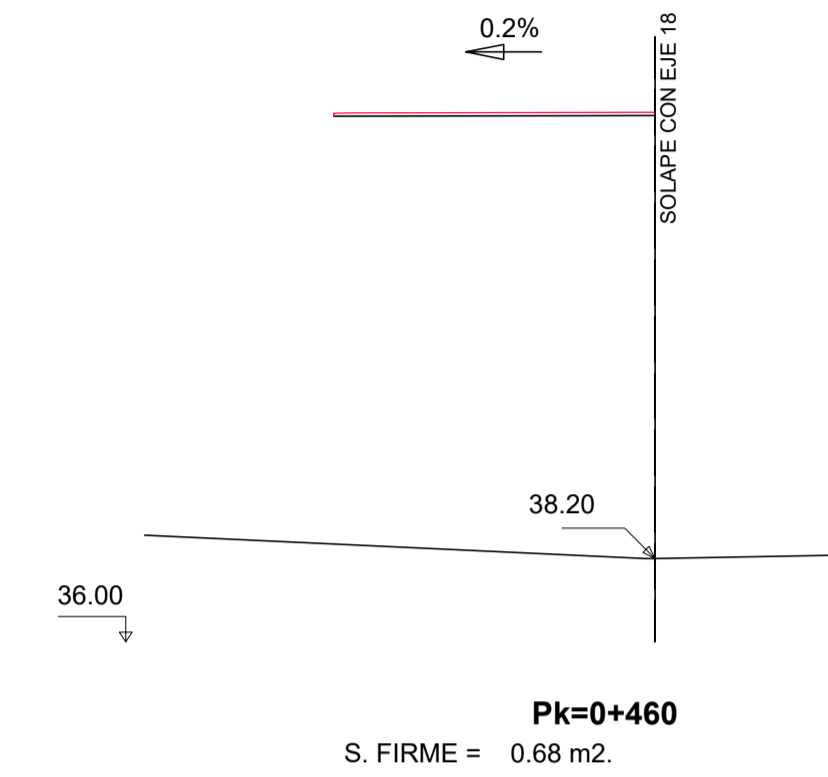
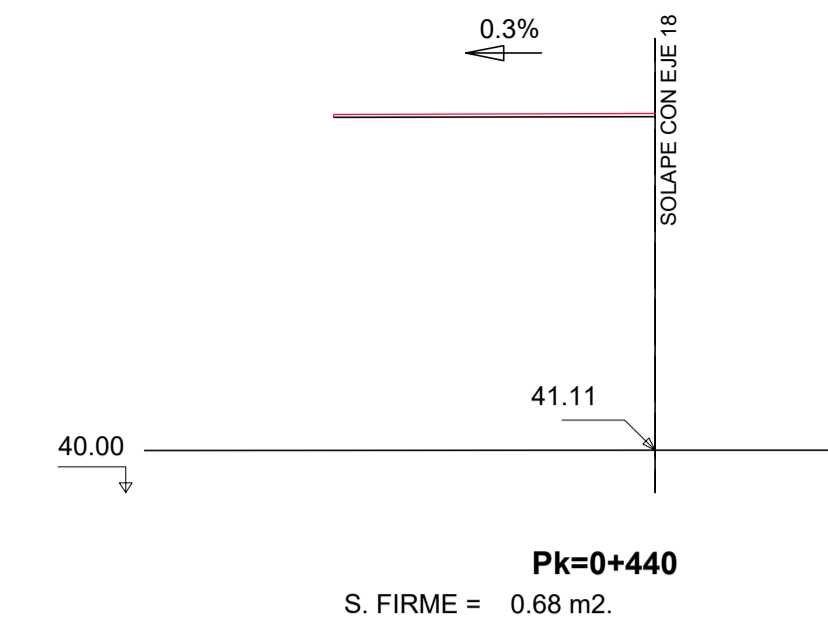
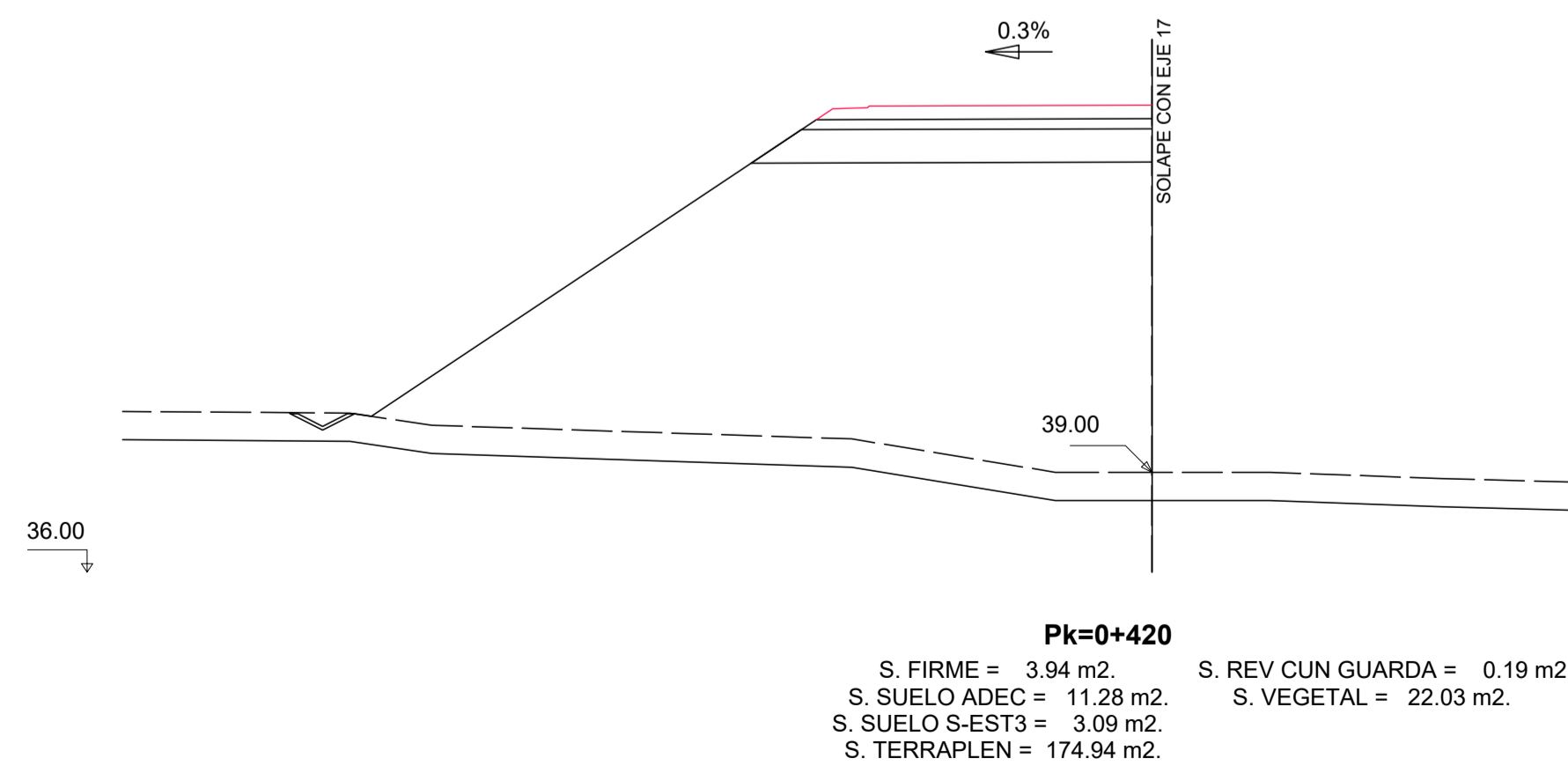
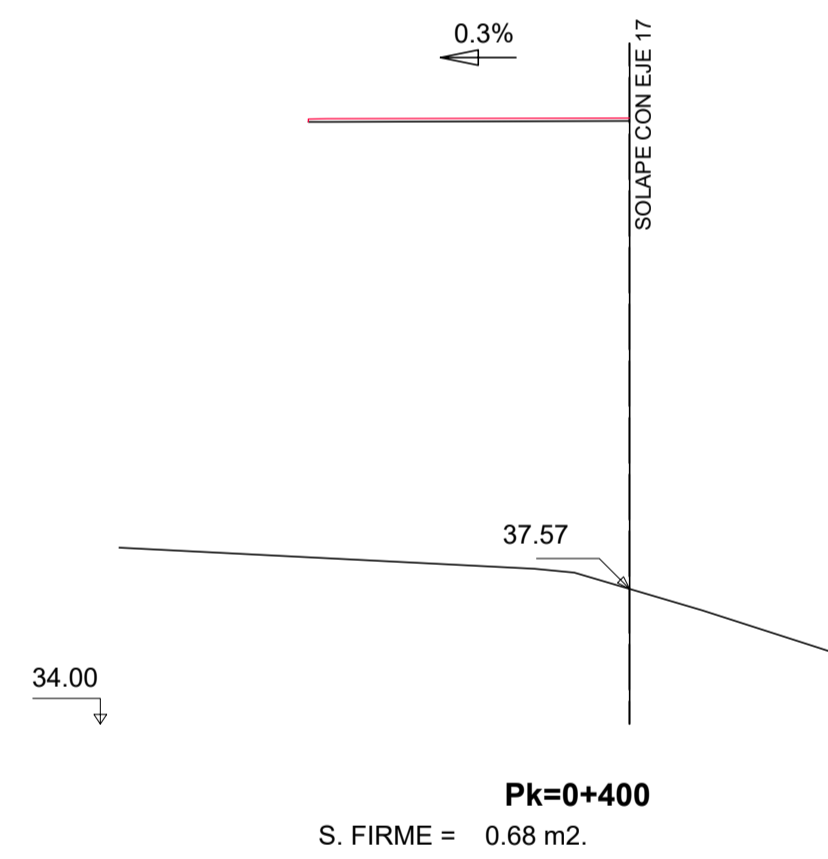
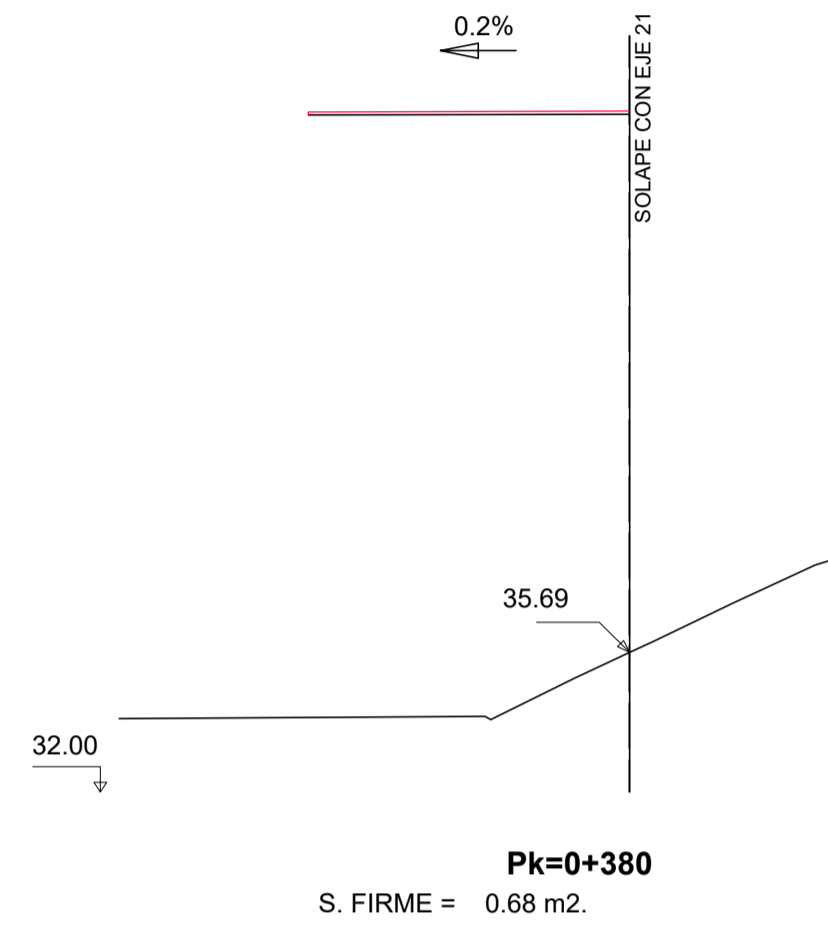
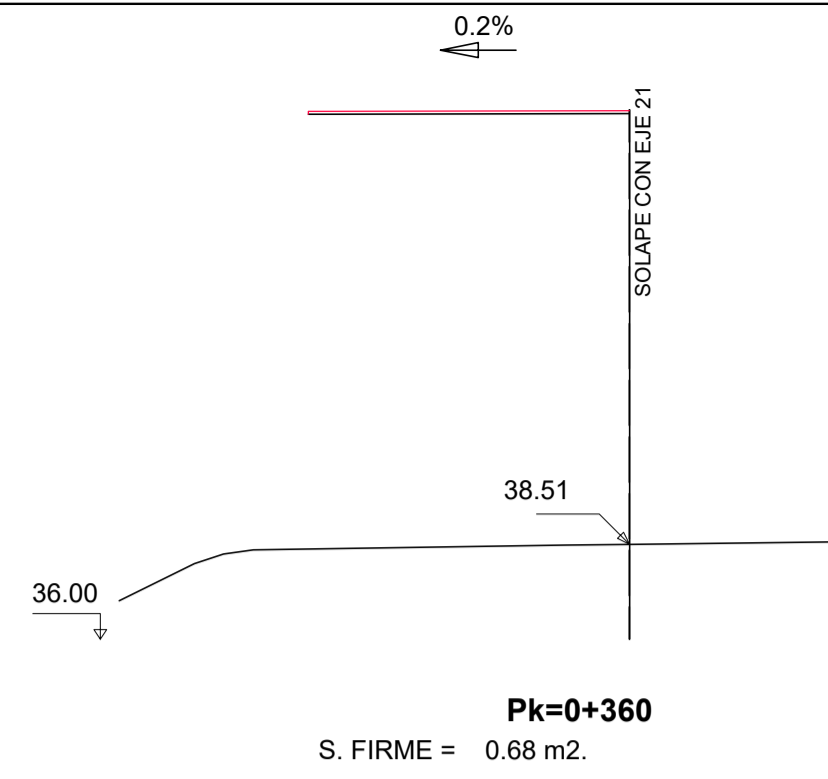
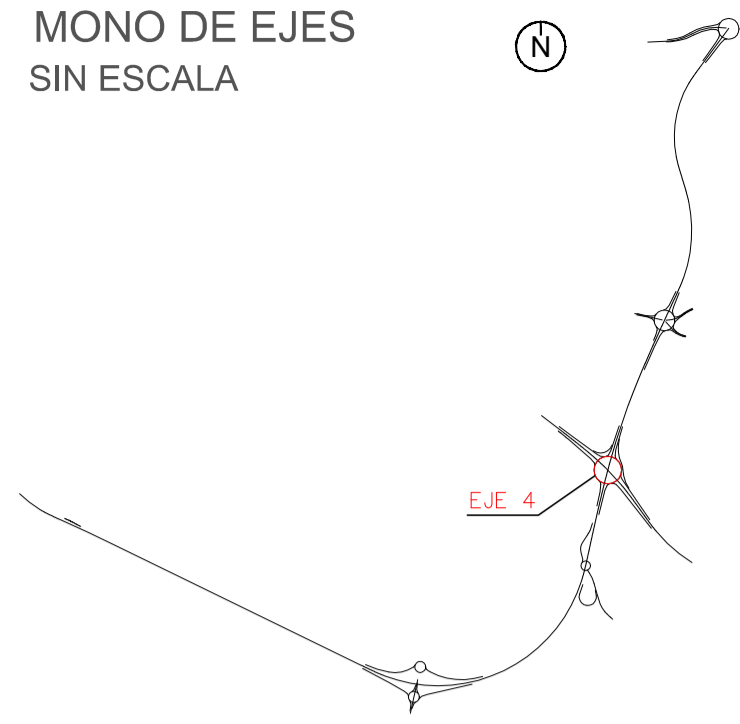

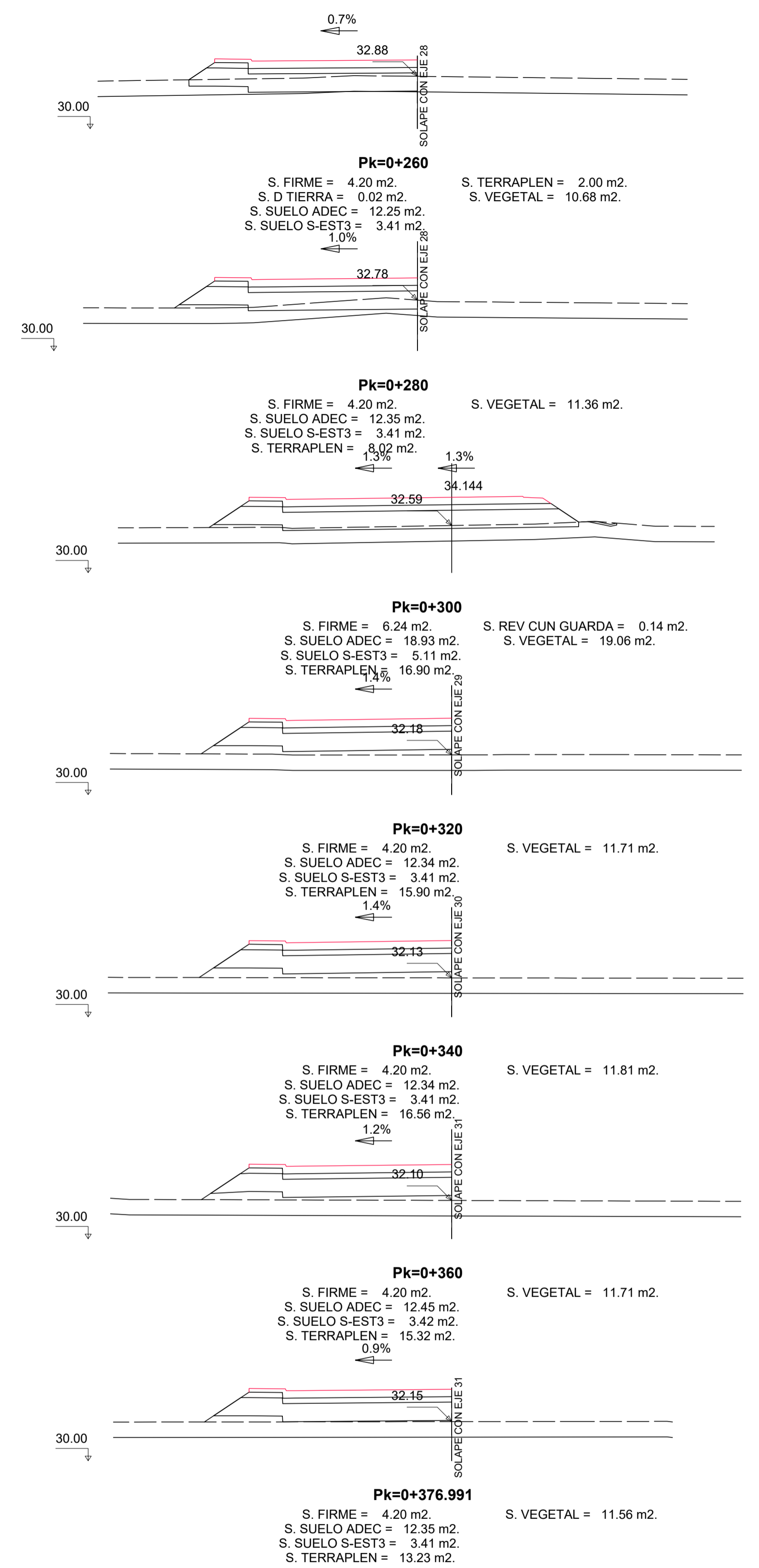
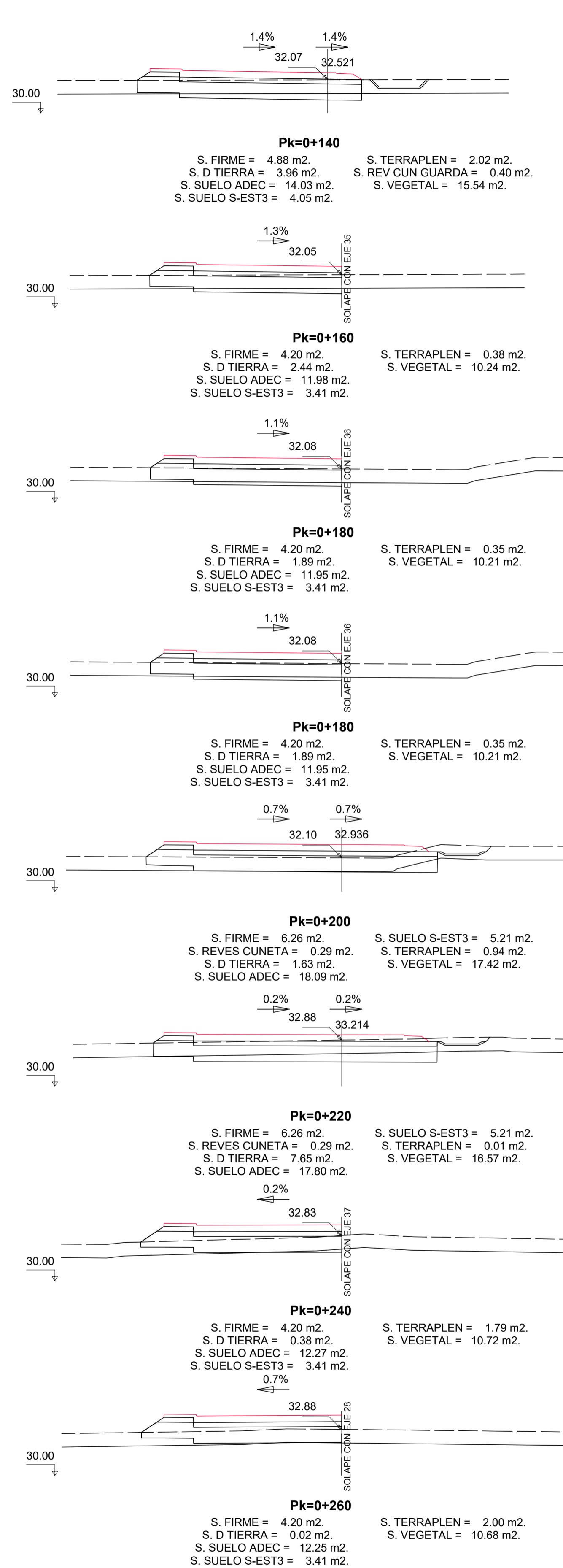
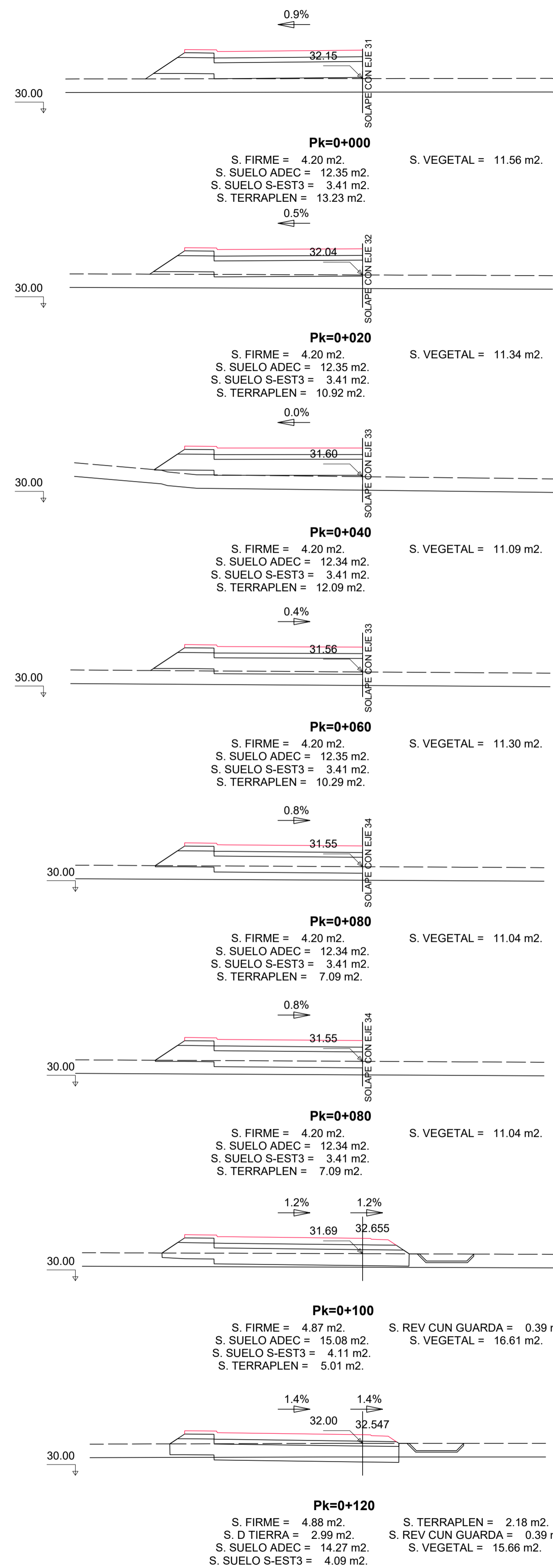
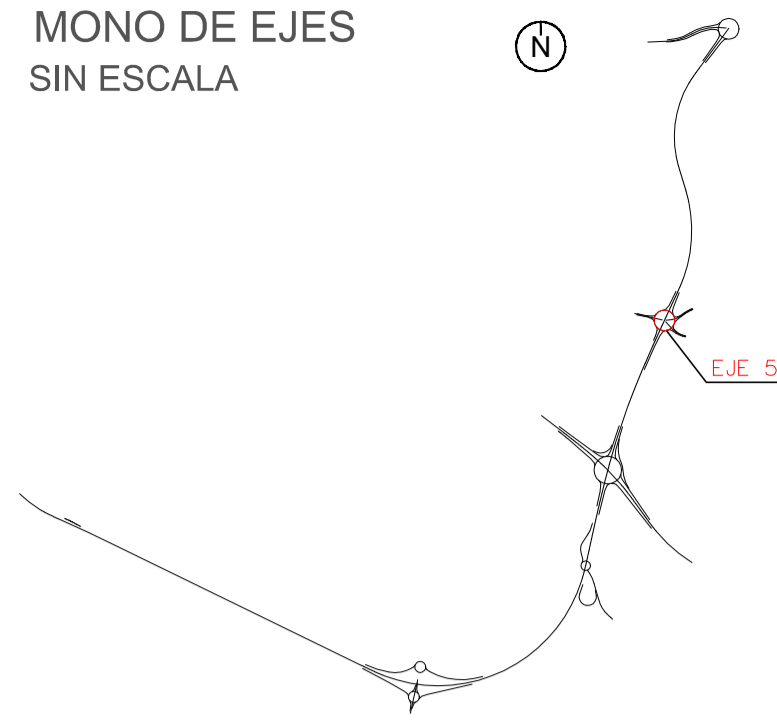

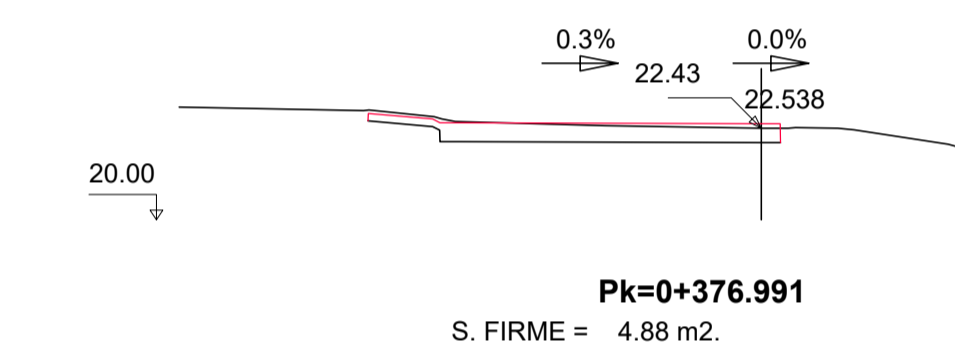
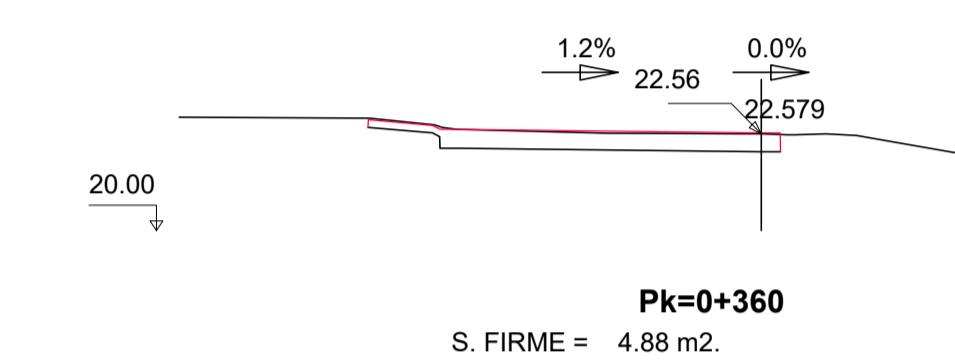
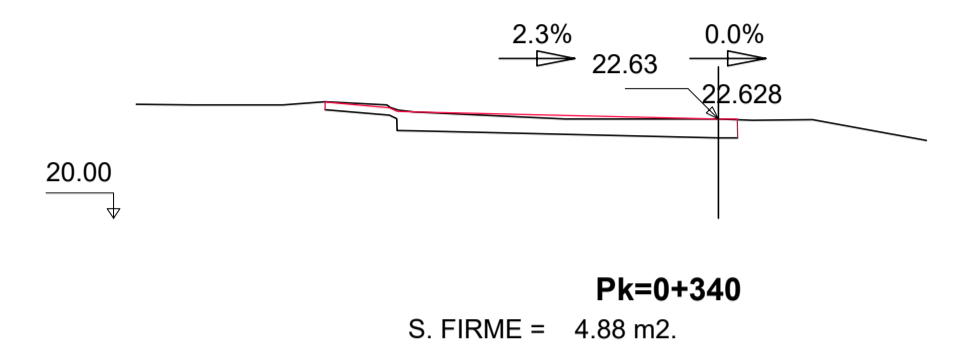
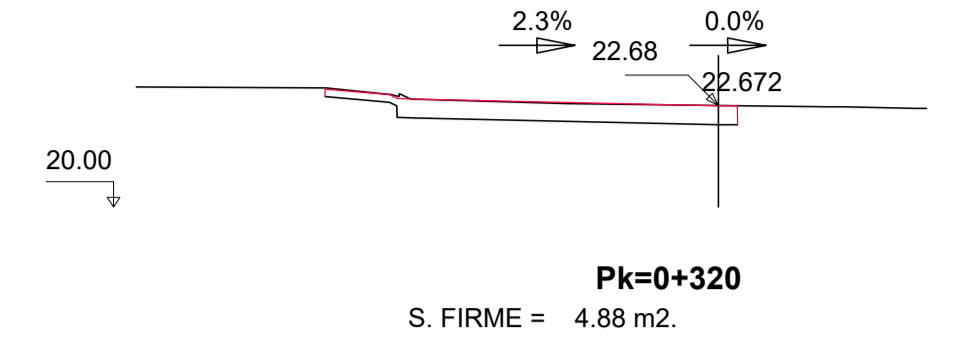
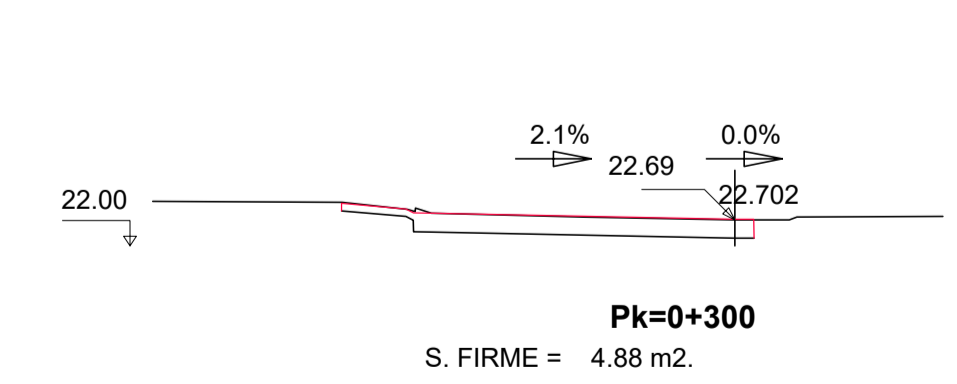
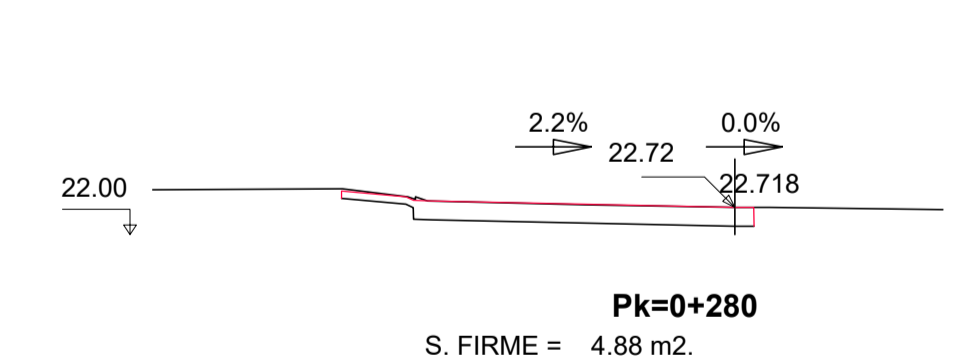
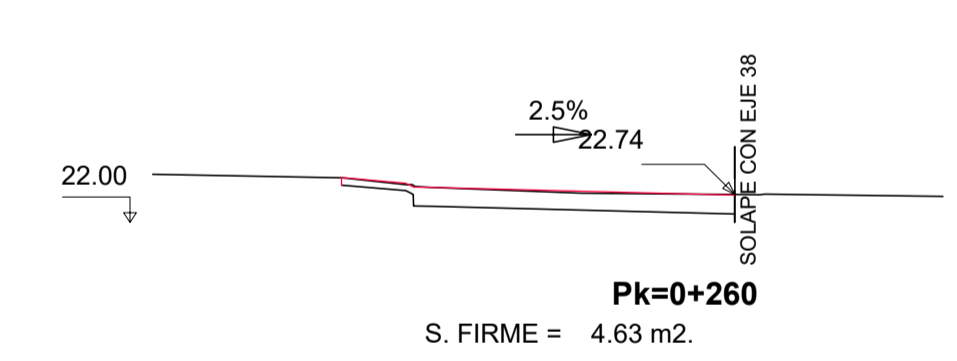
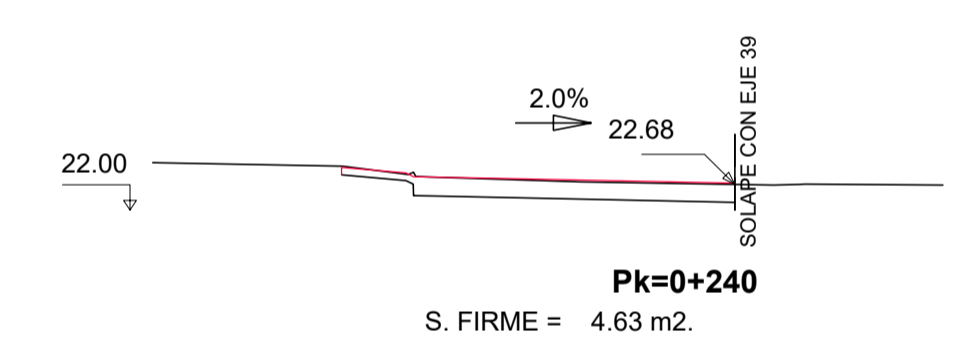
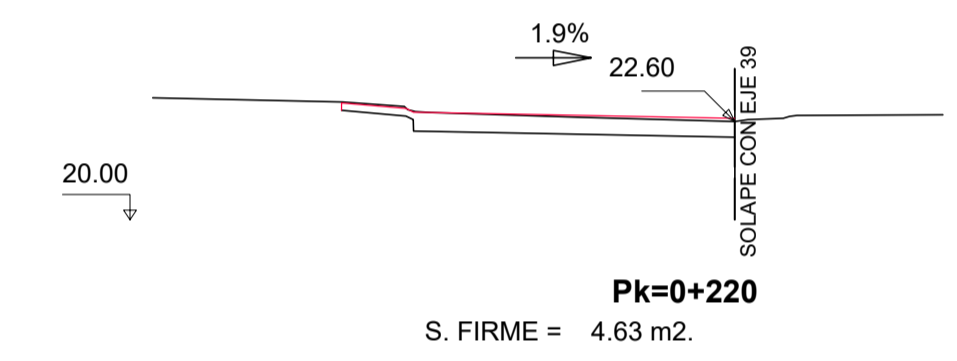
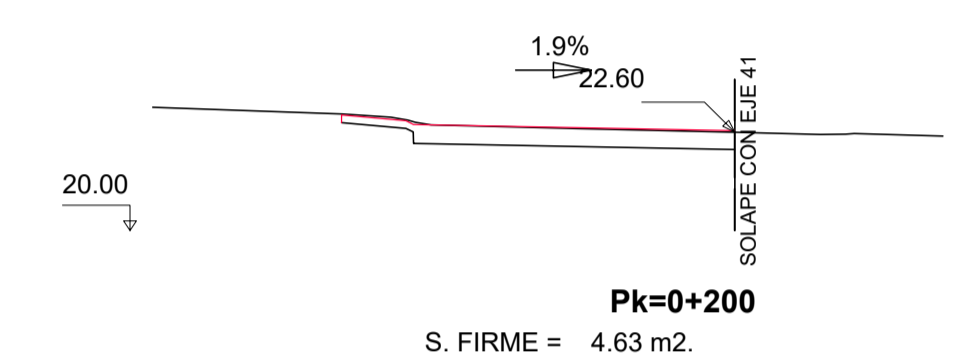
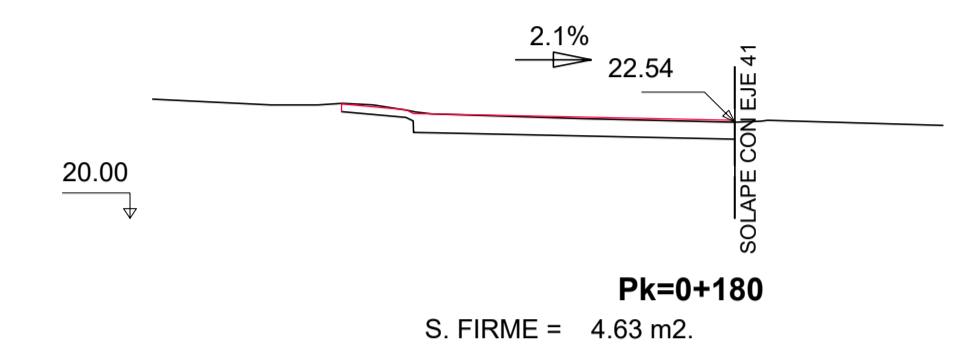
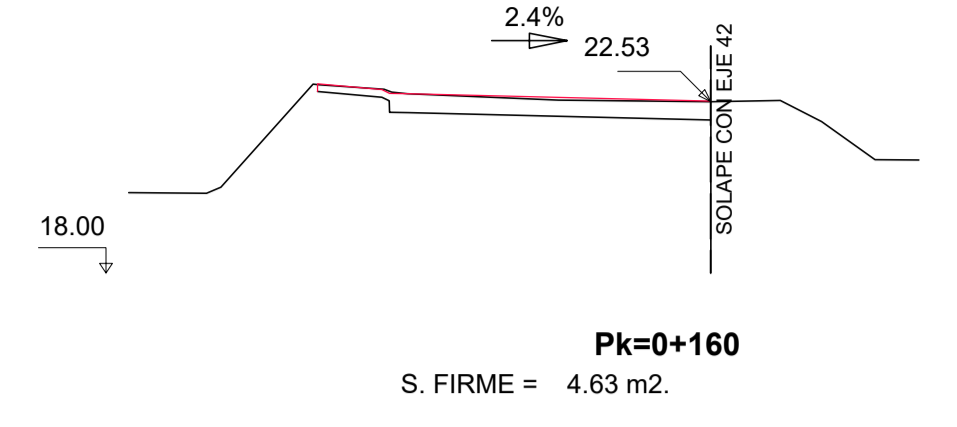
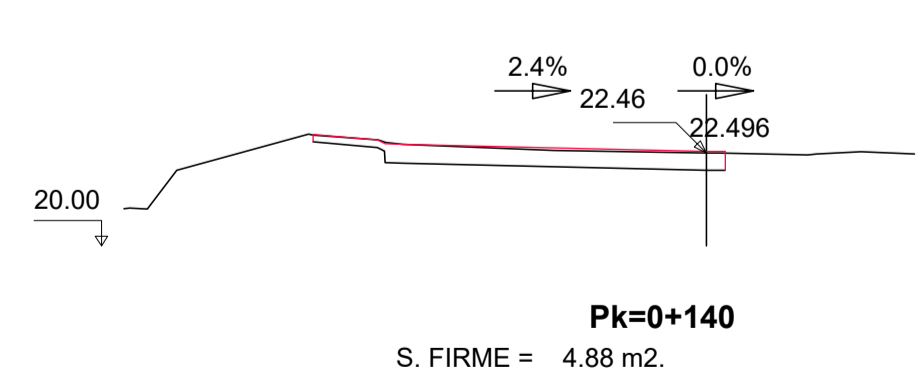
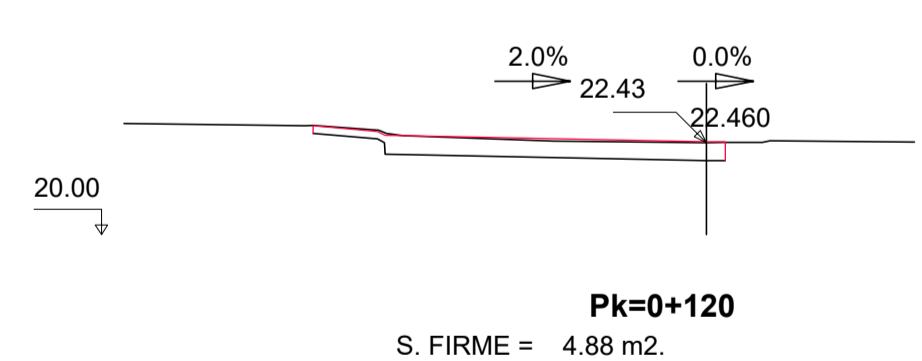
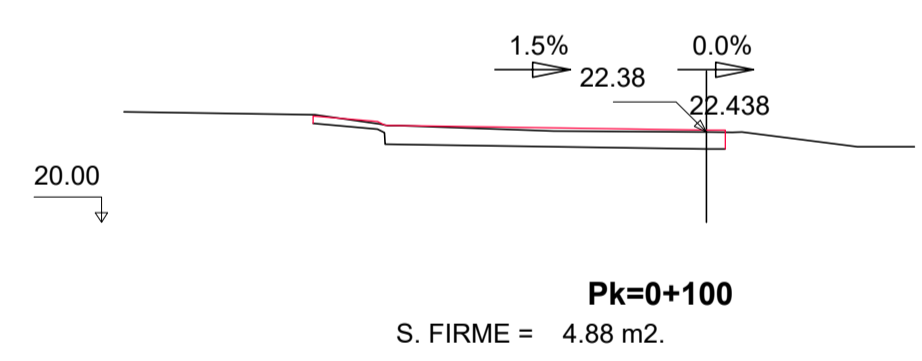
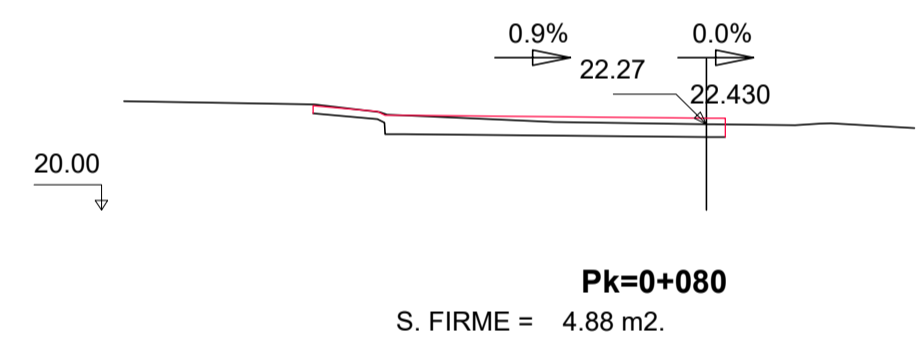
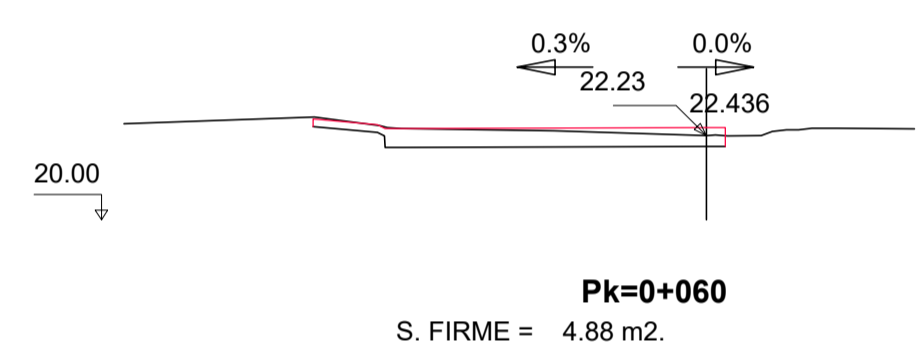
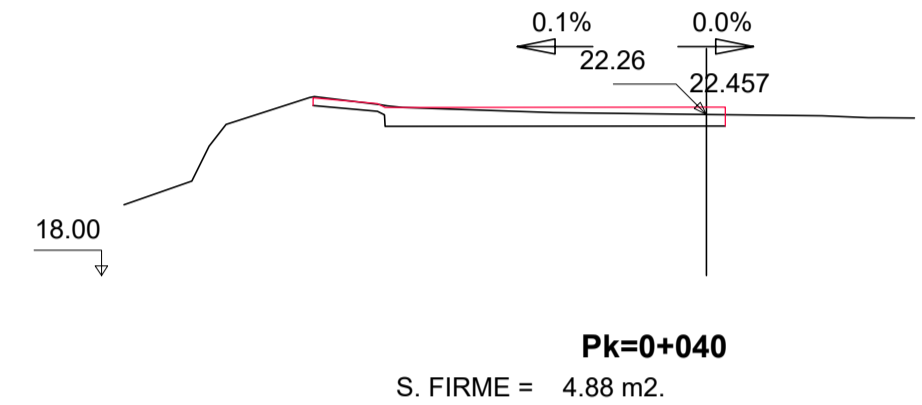
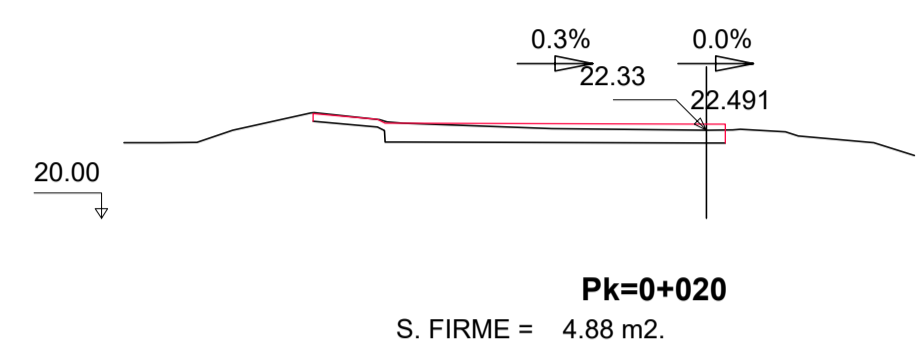
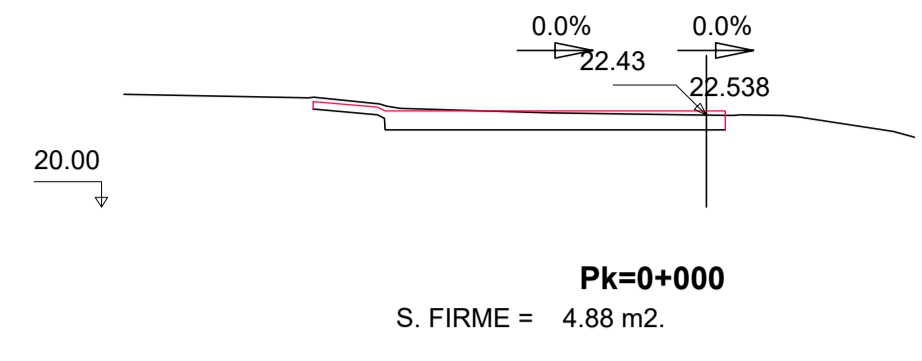

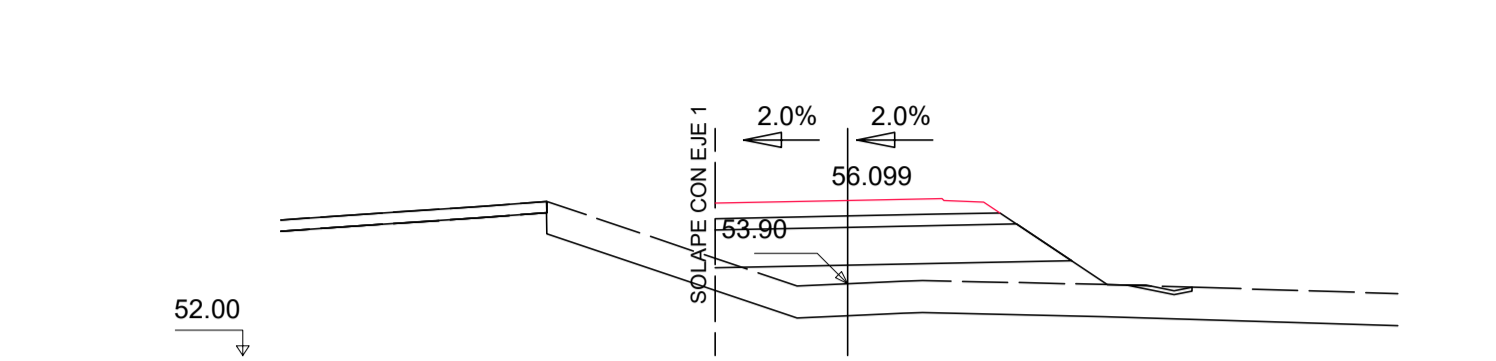
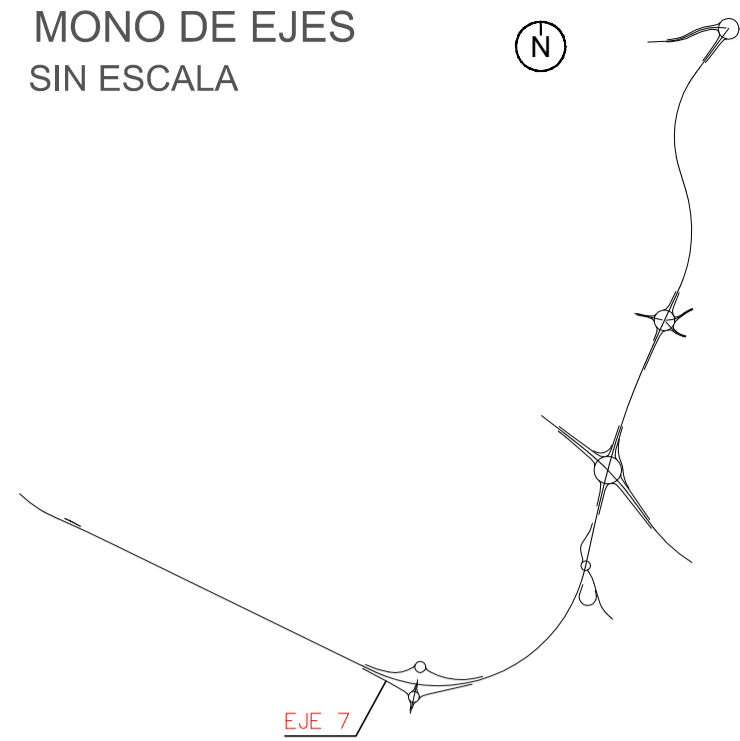

Pk=0+000
 S. FIRME = 2.89 m2. S. REV CUN GUARDA = 0.15 m2.
 S. SUELO ADEC = 8.70 m2. S. VEGETAL = 10.72 m2.
 S. SUELO S-EST3 = 2.33 m2.
 S. TERRAPLEN = 14.79 m2.

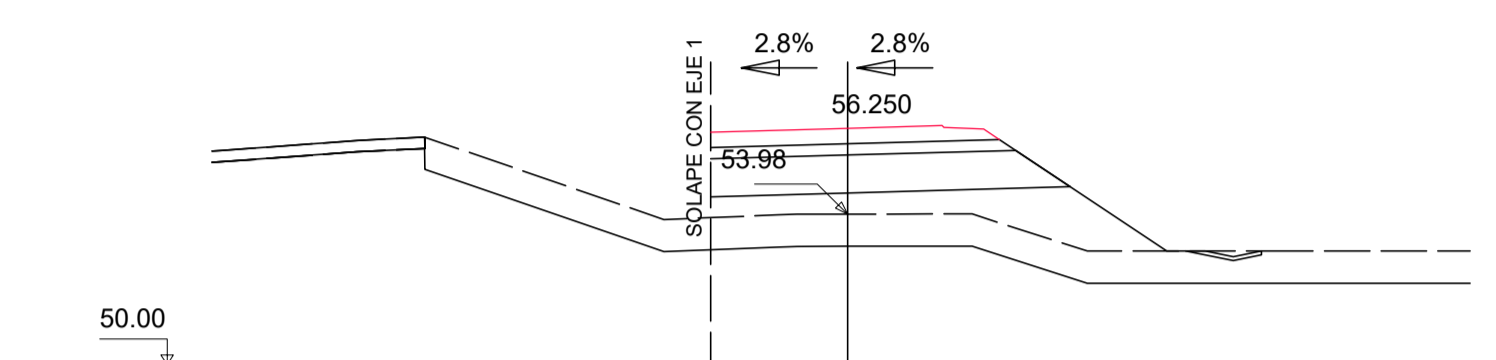

Pk=0+020
 S. FIRME = 2.93 m2. S. REV CUN GUARDA = 0.18 m2.
 S. SUELO ADEC = 8.79 m2. S. VEGETAL = 12.39 m2.
 S. SUELO S-EST3 = 2.36 m2.
 S. TERRAPLEN = 21.06 m2.

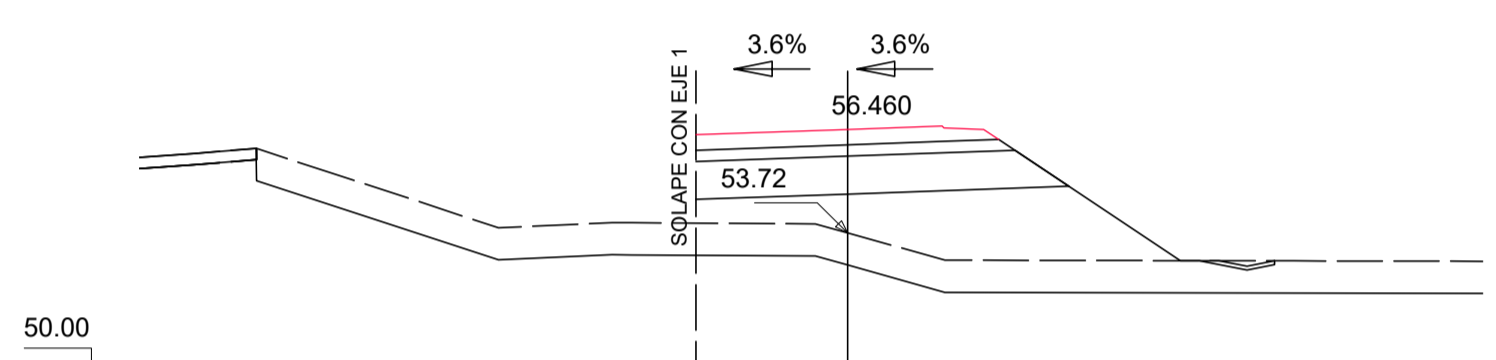

Pk=0+040
 S. FIRME = 3.08 m2. S. REV CUN GUARDA = 0.18 m2.
 S. SUELO ADEC = 9.15 m2. S. VEGETAL = 13.01 m2.
 S. SUELO S-EST3 = 2.47 m2.
 S. TERRAPLEN = 28.51 m2.

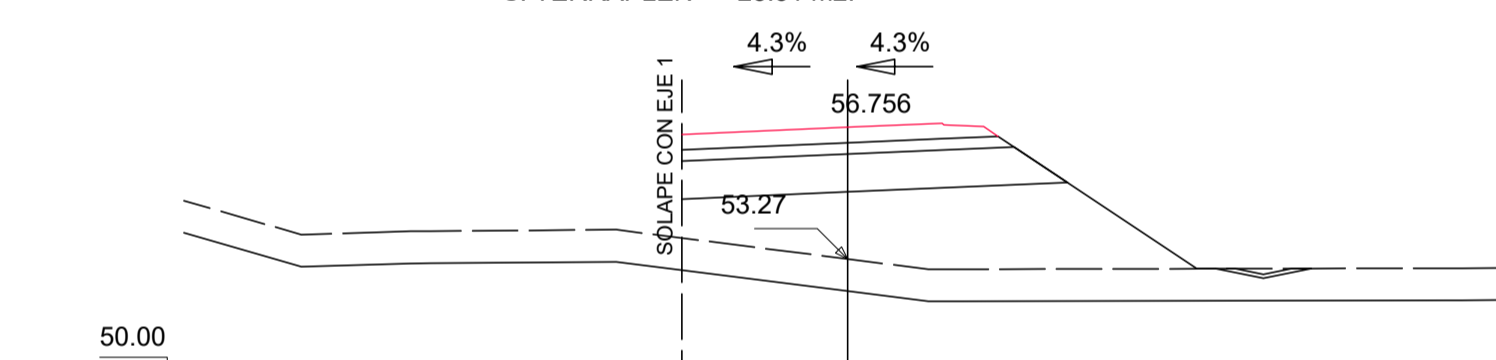

Pk=0+060
 S. FIRME = 3.23 m2. S. REV CUN GUARDA = 0.20 m2.
 S. SUELO ADEC = 9.50 m2. S. VEGETAL = 14.15 m2.
 S. SUELO S-EST3 = 2.57 m2.
 S. TERRAPLEN = 36.23 m2.

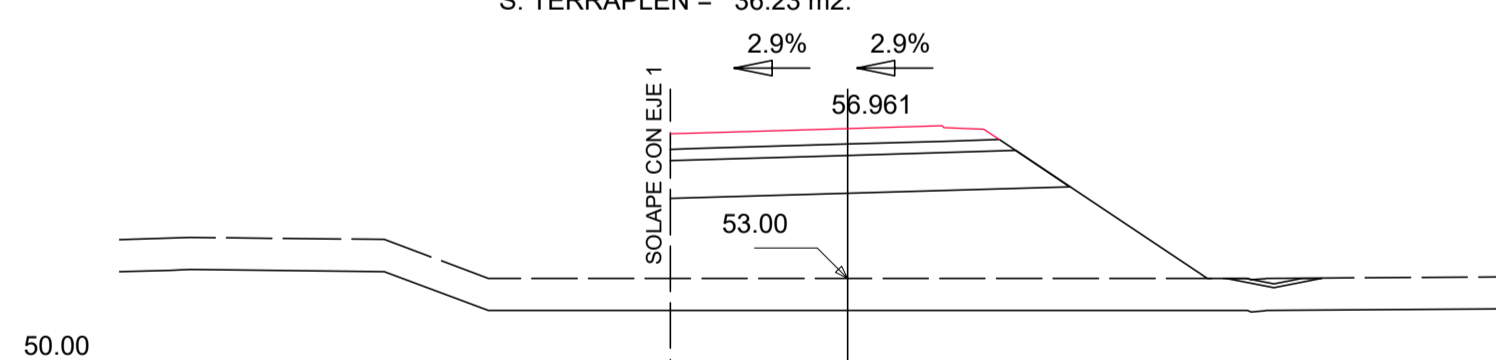

Pk=0+080
 S. FIRME = 3.36 m2. S. REV CUN GUARDA = 0.20 m2.
 S. SUELO ADEC = 9.85 m2. S. VEGETAL = 14.64 m2.
 S. SUELO S-EST3 = 2.67 m2.
 S. TERRAPLEN = 42.70 m2.

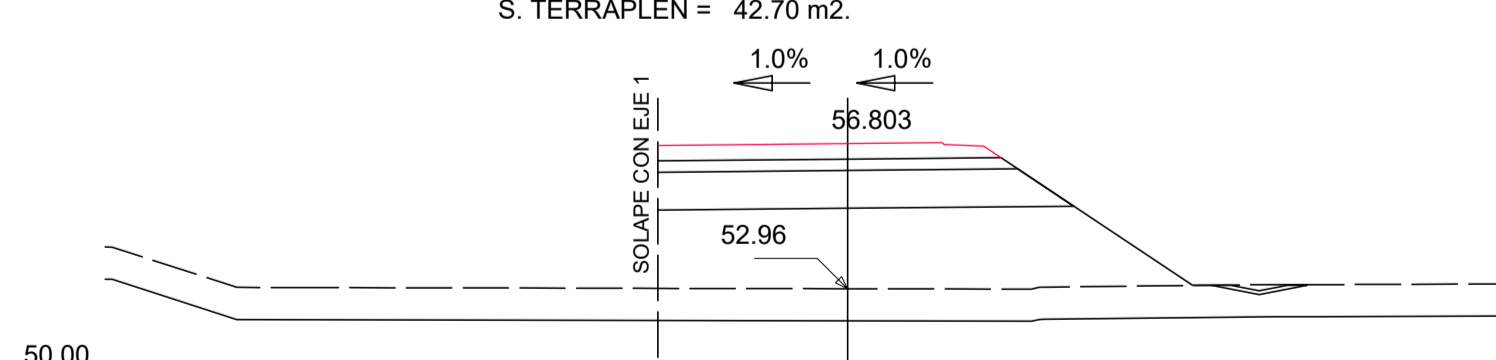

Pk=0+100
 S. FIRME = 3.52 m2. S. REV CUN GUARDA = 0.20 m2.
 S. SUELO ADEC = 10.26 m2. S. VEGETAL = 14.60 m2.
 S. SUELO S-EST3 = 2.79 m2.
 S. TERRAPLEN = 41.03 m2.

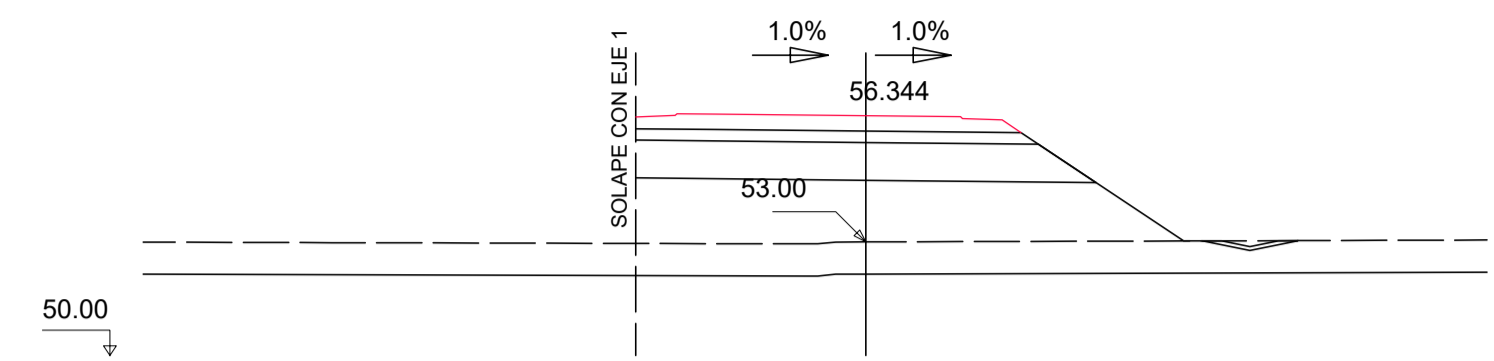

Pk=0+120
 S. FIRME = 3.91 m2. S. REV CUN GUARDA = 0.20 m2.
 S. SUELO ADEC = 11.41 m2. S. VEGETAL = 14.89 m2.
 S. SUELO S-EST3 = 3.13 m2.
 S. TERRAPLEN = 36.39 m2.

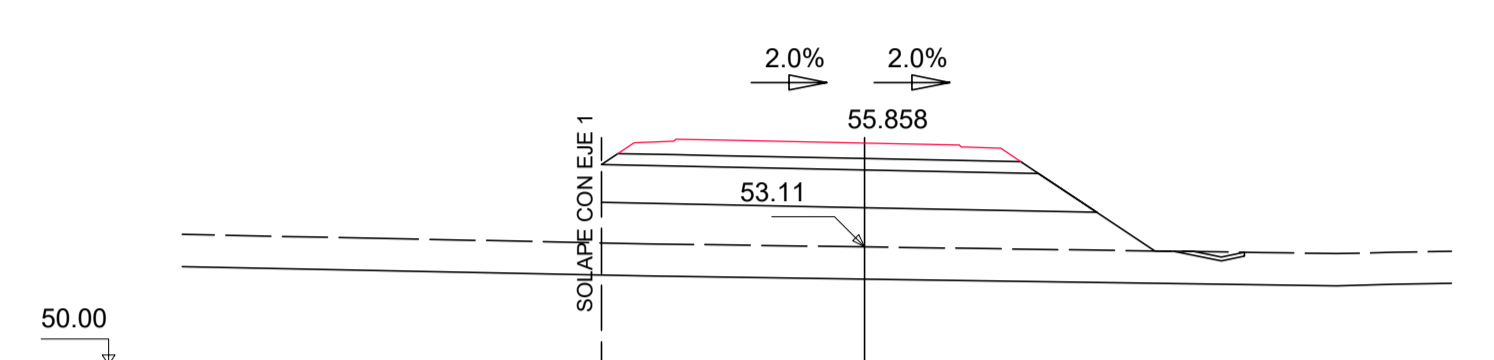

Pk=0+140
 S. FIRME = 3.98 m2. S. REV CUN GUARDA = 0.16 m2.
 S. SUELO ADEC = 12.33 m2. S. VEGETAL = 14.46 m2.
 S. SUELO S-EST3 = 3.33 m2.
 S. TERRAPLEN = 28.59 m2.

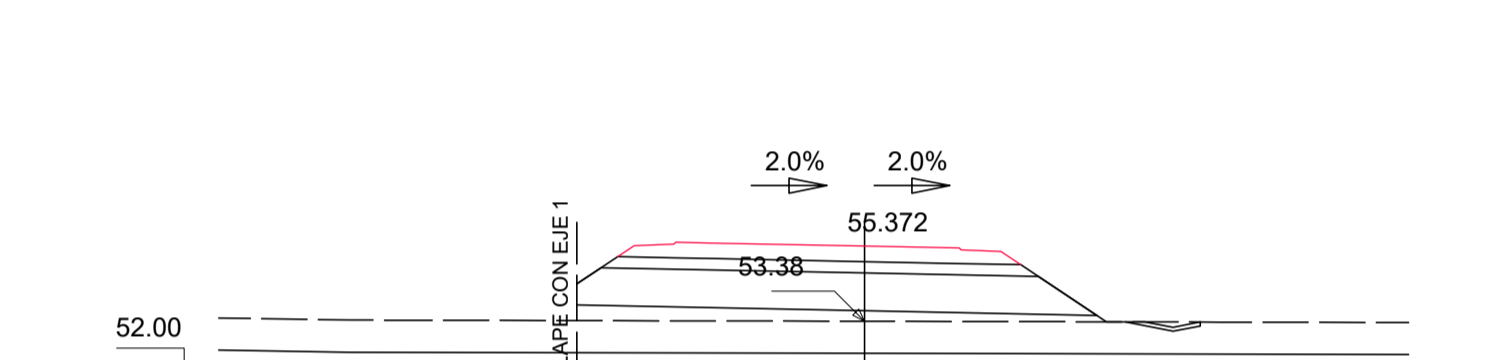

Pk=0+160
 S. FIRME = 3.98 m2. S. REV CUN GUARDA = 0.18 m2.
 S. SUELO ADEC = 12.84 m2. S. VEGETAL = 14.02 m2.
 S. SUELO S-EST3 = 3.33 m2.
 S. TERRAPLEN = 17.75 m2.

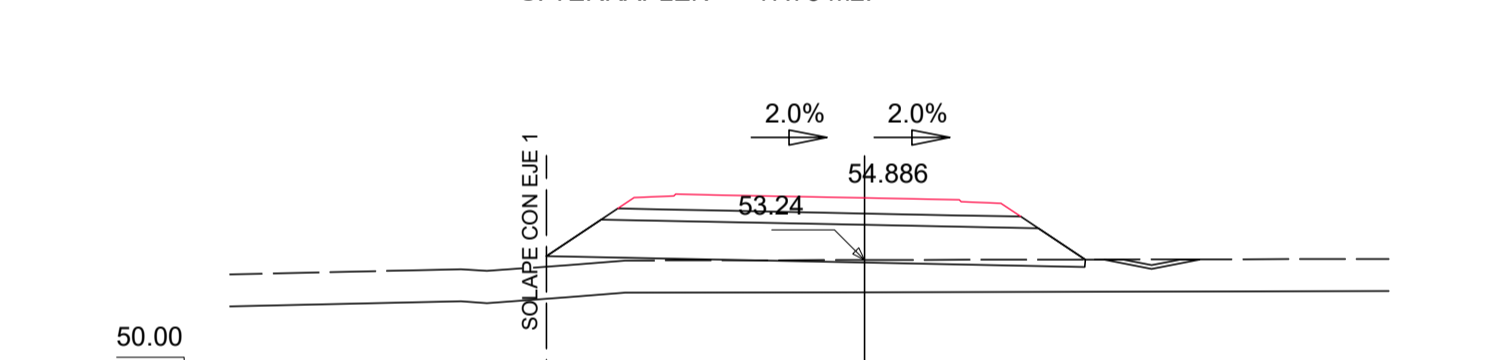

Pk=0+180
 S. FIRME = 3.98 m2. S. REV CUN GUARDA = 0.20 m2.
 S. SUELO ADEC = 13.03 m2. S. VEGETAL = 14.69 m2.
 S. SUELO S-EST3 = 3.33 m2.
 S. TERRAPLEN = 13.97 m2.

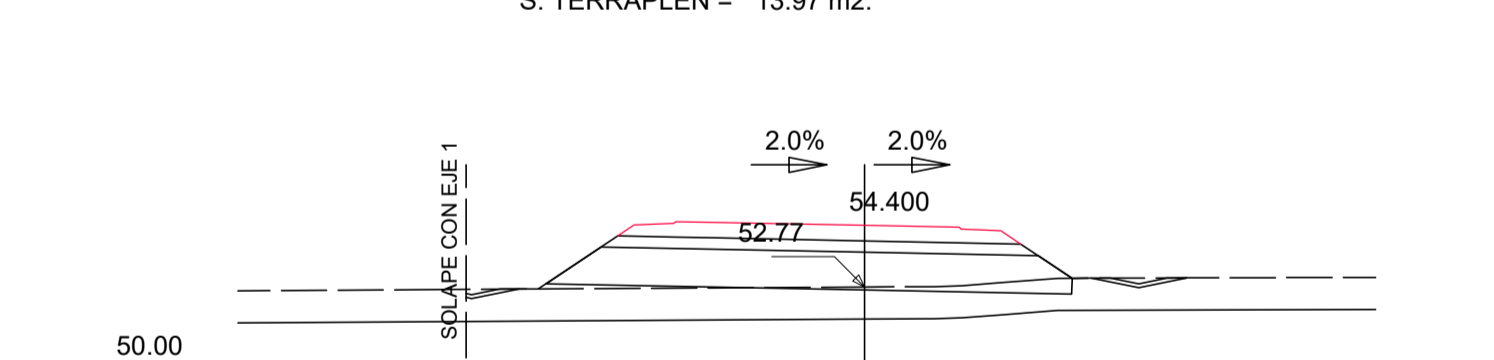

Pk=0+200
 S. FIRME = 3.98 m2. S. REV CUN GUARDA = 0.32 m2.
 S. SUELO ADEC = 12.93 m2. S. VEGETAL = 16.20 m2.
 S. SUELO S-EST3 = 3.33 m2.
 S. TERRAPLEN = 14.76 m2.

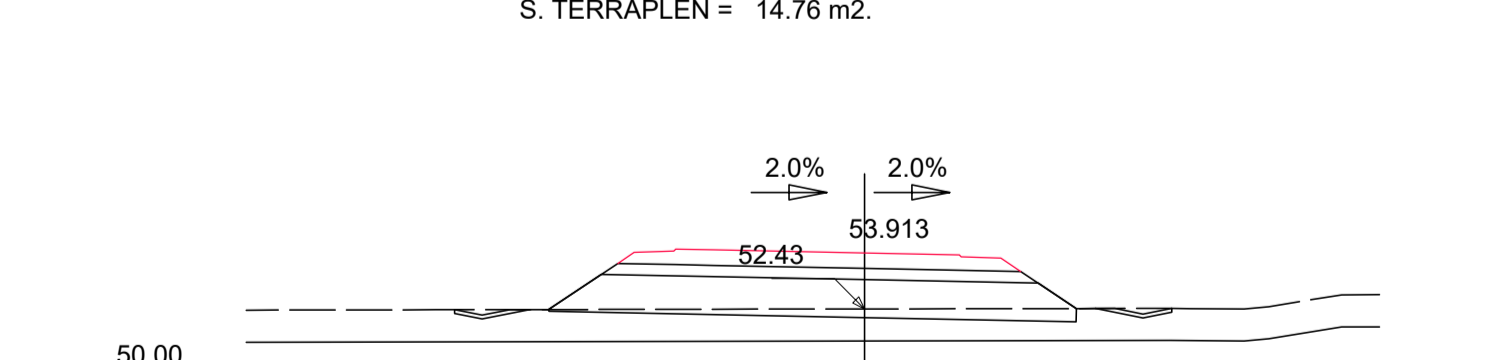

Pk=0+220
 S. FIRME = 3.98 m2. S. REV CUN GUARDA = 0.36 m2.
 S. SUELO ADEC = 12.97 m2. S. VEGETAL = 16.13 m2.
 S. SUELO S-EST3 = 3.33 m2.
 S. TERRAPLEN = 12.81 m2.

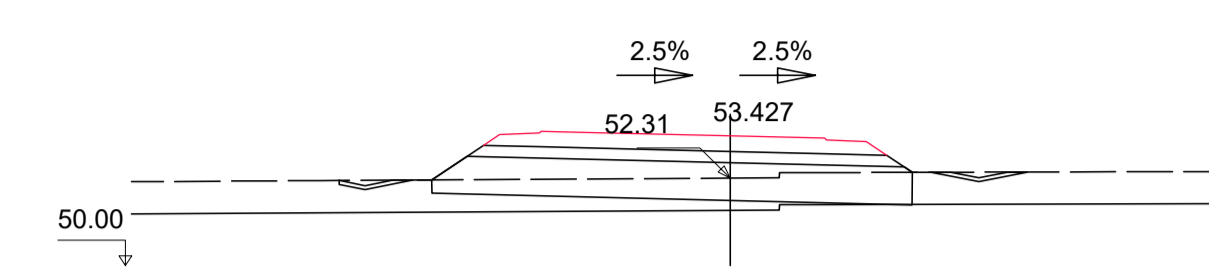

Pk=0+240
 S. FIRME = 3.98 m2. S. TERRAPLEN = 7.48 m2.
 S. D TIERRA = 0.00 m2. S. REV CUN GUARDA = 0.38 m2.
 S. SUELO ADEC = 12.39 m2. S. VEGETAL = 15.46 m2.
 S. SUELO S-EST3 = 3.33 m2.

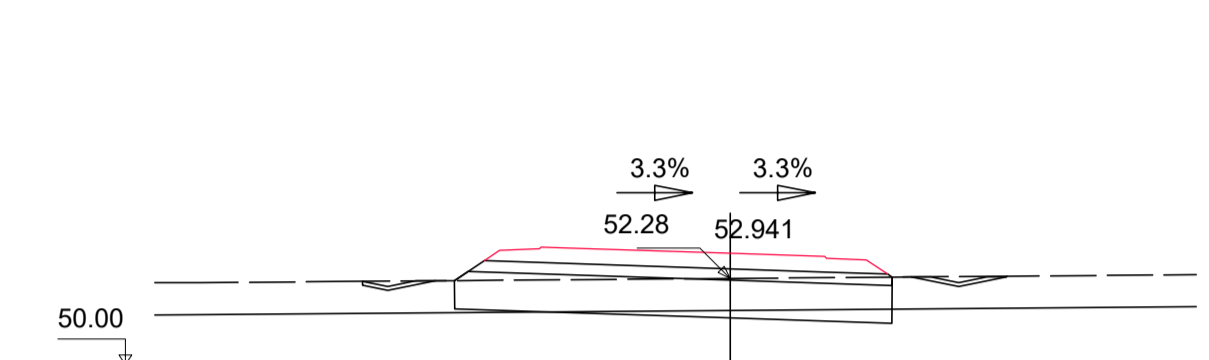

Pk=0+260
 S. FIRME = 3.99 m2. S. TERRAPLEN = 4.18 m2.
 S. D TIERRA = 1.69 m2. S. REV CUN GUARDA = 0.37 m2.
 S. SUELO ADEC = 11.53 m2. S. VEGETAL = 14.49 m2.
 S. SUELO S-EST3 = 3.30 m2.

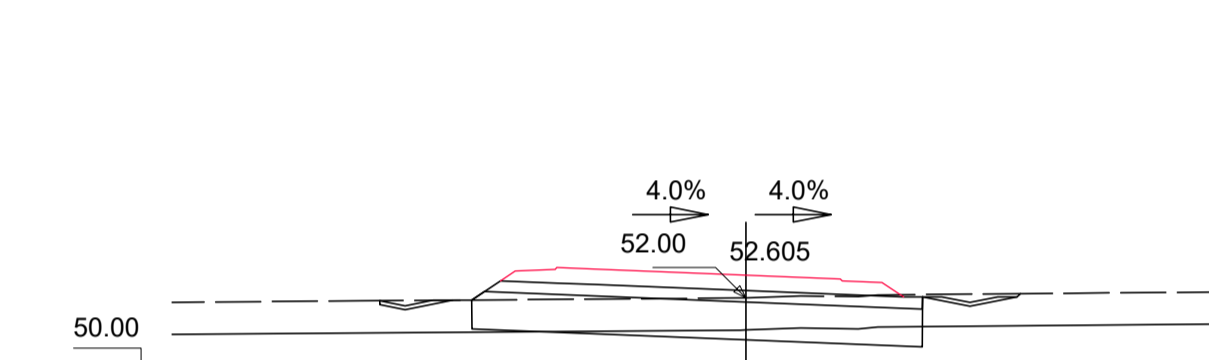

Pk=0+280
 S. FIRME = 3.98 m2. S. SUELO S-EST3 = 3.42 m2.
 S. REVES CUNETAS = 0.20 m2. S. TERRAPLEN = 1.89 m2.
 S. D TIERRA = 2.55 m2. S. REV CUN GUARDA = 0.17 m2.
 S. SUELO ADEC = 11.88 m2. S. VEGETAL = 12.71 m2.

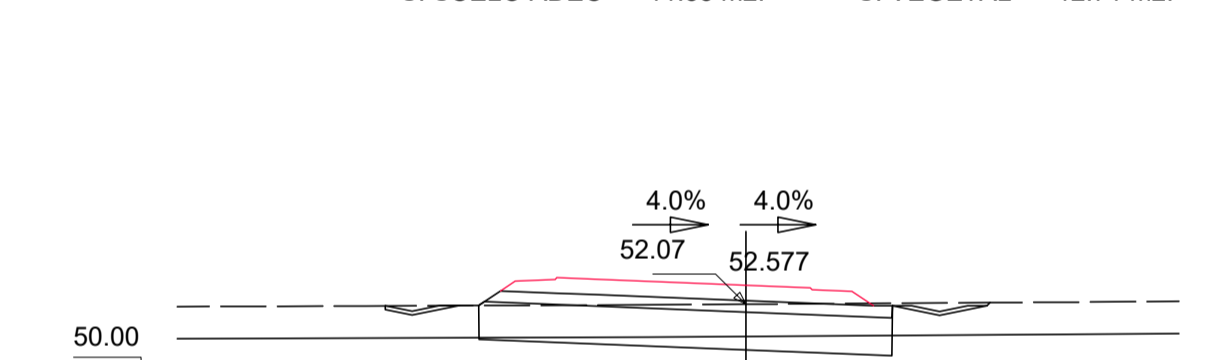

Pk=0+300
 S. FIRME = 3.65 m2. S. SUELO S-EST3 = 3.18 m2.
 S. REVES CUNETAS = 0.20 m2. S. TERRAPLEN = 1.83 m2.
 S. D TIERRA = 3.11 m2. S. REV CUN GUARDA = 0.17 m2.
 S. SUELO ADEC = 10.93 m2. S. VEGETAL = 11.91 m2.

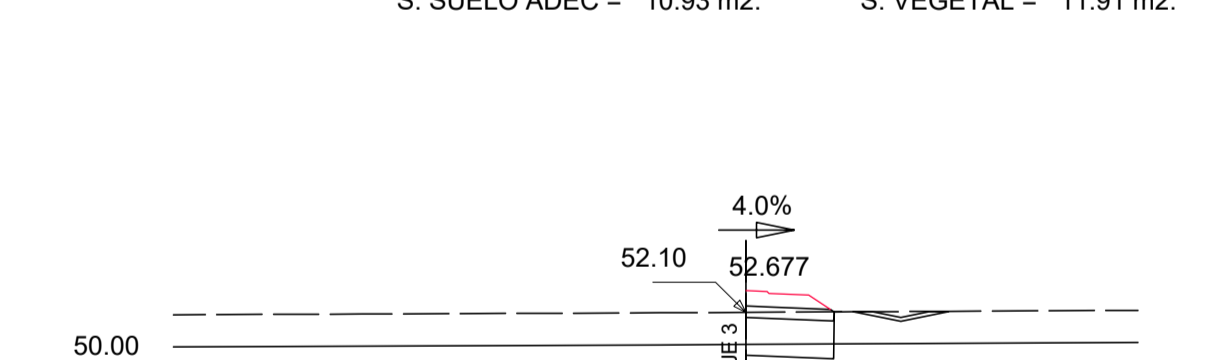

Pk=0+314.225
 S. FIRME = 0.73 m2. S. TERRAPLEN = 2.25 m2.
 S. D TIERRA = 0.78 m2. S. REV CUN GUARDA = 0.20 m2.
 S. SUELO ADEC = 2.33 m2. S. VEGETAL = 4.56 m2.
 S. SUELO S-EST3 = 0.70 m2.

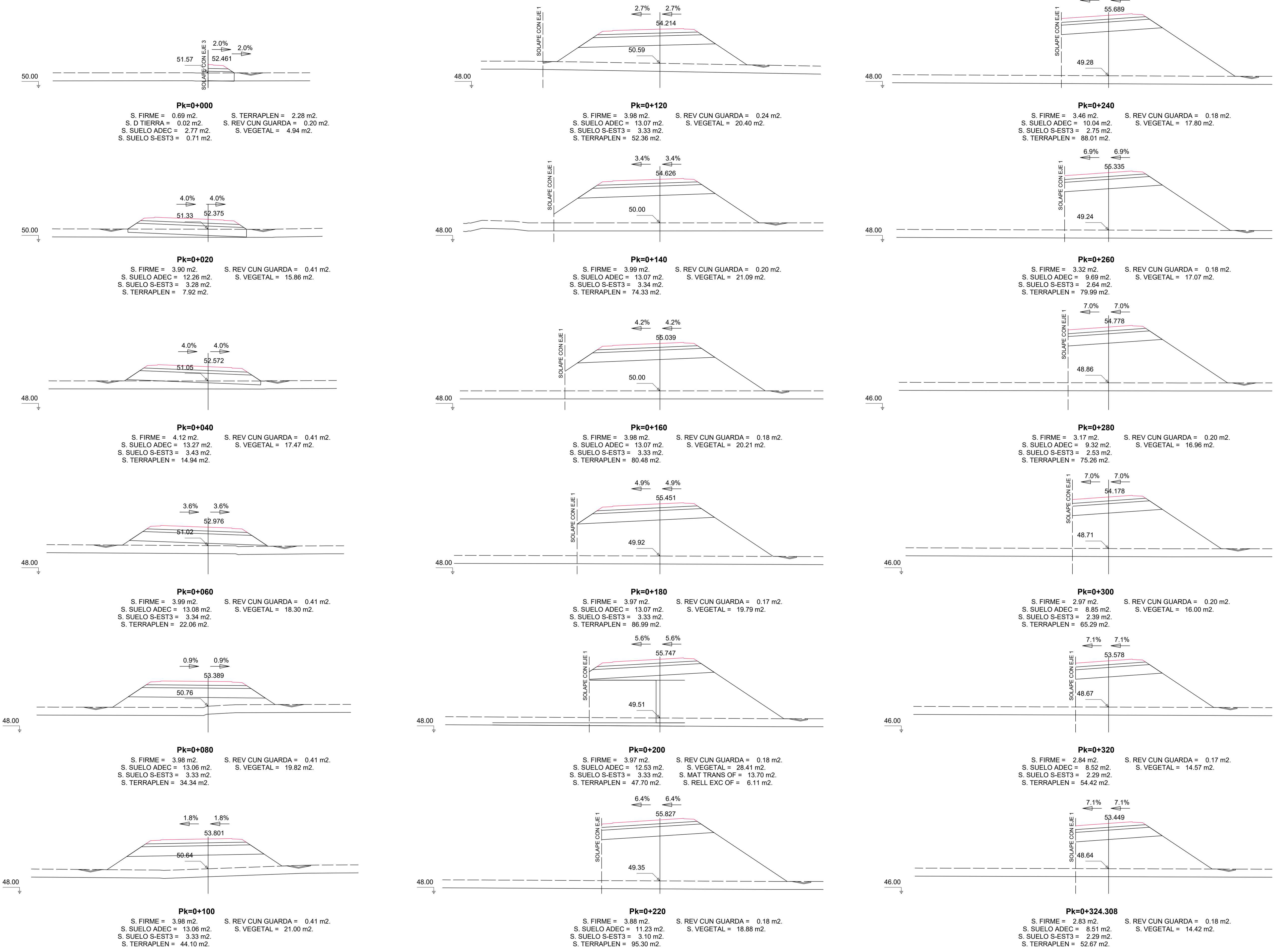
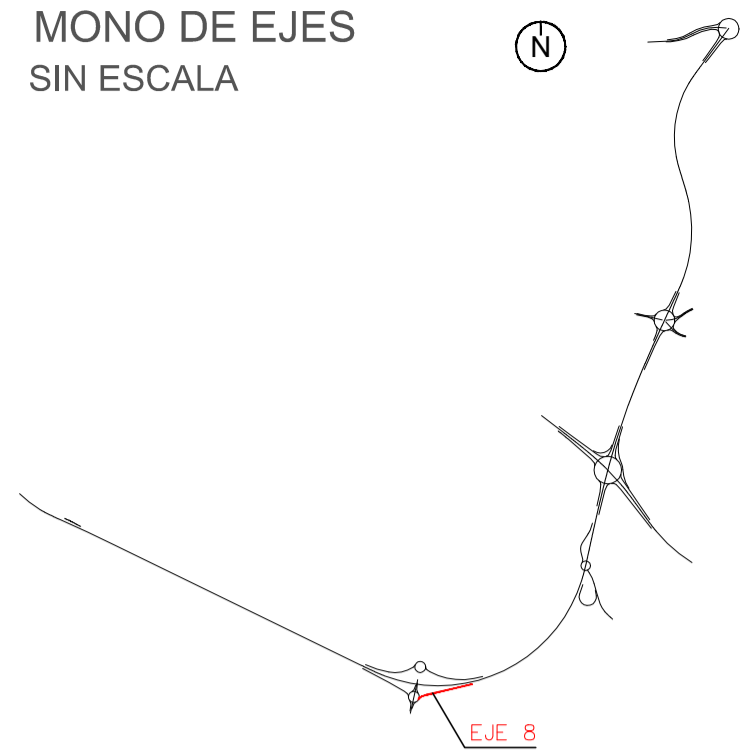



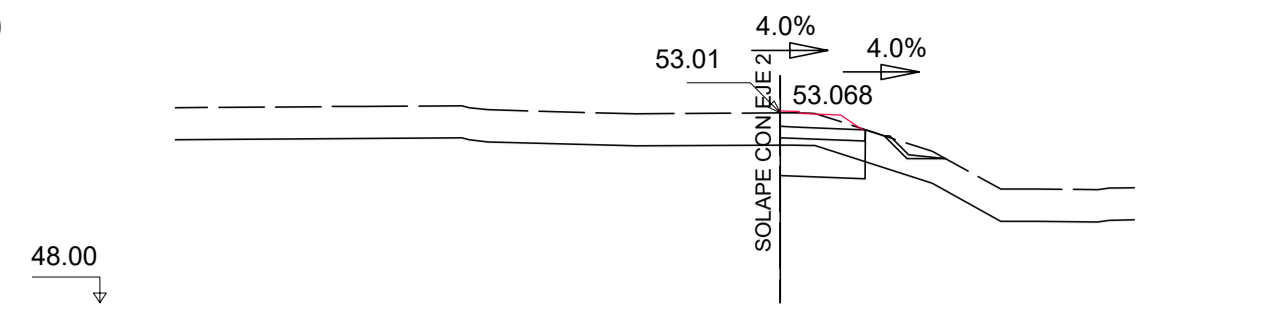
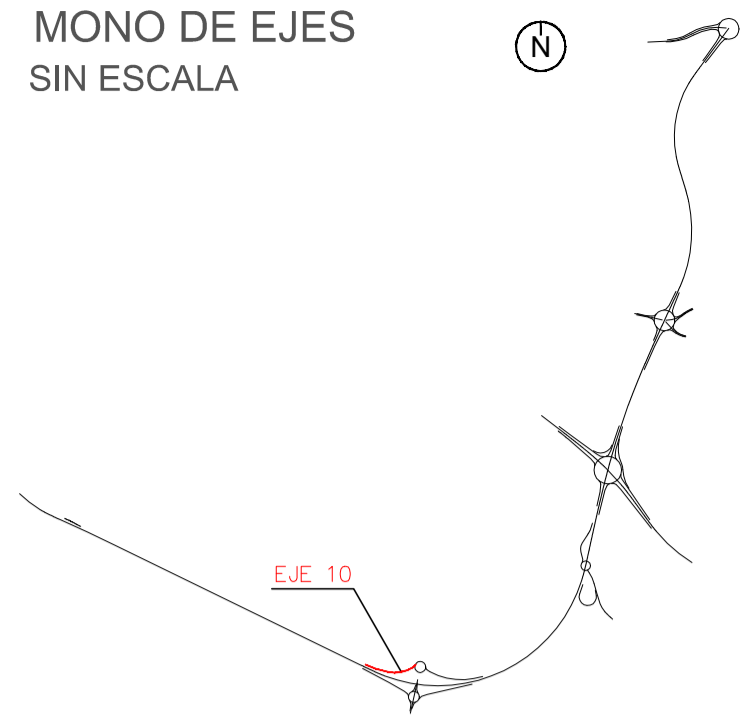

Pk=0+000
 S. FIRME = 0.71 m2. S. D TIERRA = 1.61 m2. S. SUELO ADEC = 2.26 m2. S. SUELO S-EST3 = 0.68 m2.
 S. TERRAPLEN = 1.45 m2. S. REV CUN GUARDA = 0.13 m2. S. VEGETAL = 3.72 m2.

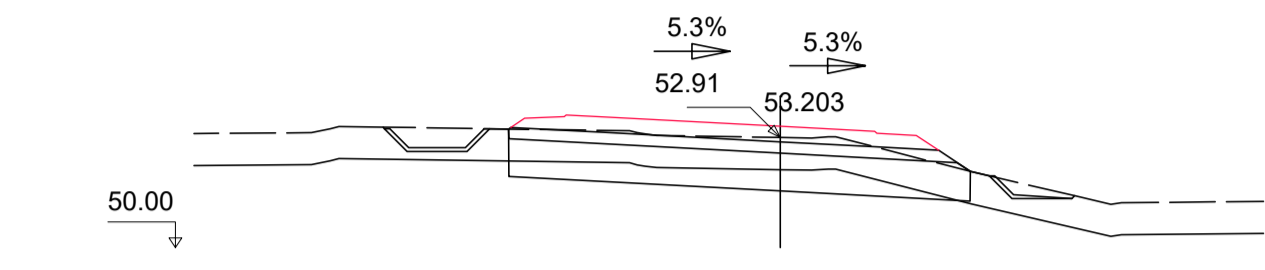

Pk=0+020
 S. FIRME = 4.24 m2. S. D TIERRA = 5.44 m2. S. SUELO ADEC = 12.17 m2. S. SUELO S-EST3 = 3.48 m2.
 S. TERRAPLEN = 3.24 m2. S. REV CUN GUARDA = 0.47 m2. S. VEGETAL = 15.55 m2.

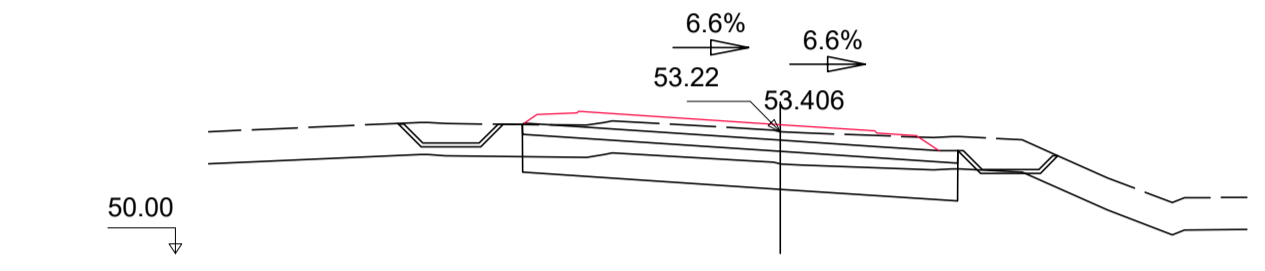

Pk=0+040
 S. FIRME = 4.10 m2. S. D TIERRA = 7.75 m2. S. SUELO ADEC = 11.51 m2. S. SUELO S-EST3 = 3.46 m2.
 S. REVES CUNETAS = 0.29 m2. S. TERRAPLEN = 1.56 m2. S. REV CUN GUARDA = 0.31 m2. S. VEGETAL = 14.57 m2.

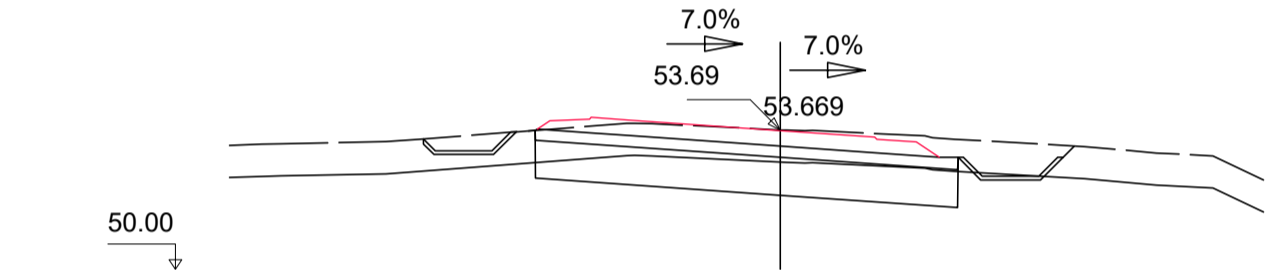

Pk=0+060
 S. FIRME = 3.96 m2. S. D TIERRA = 9.48 m2. S. SUELO ADEC = 11.18 m2. S. SUELO S-EST3 = 3.36 m2.
 S. REVES CUNETAS = 0.31 m2. S. TERRAPLEN = 1.56 m2. S. REV CUN GUARDA = 0.27 m2. S. VEGETAL = 14.29 m2.

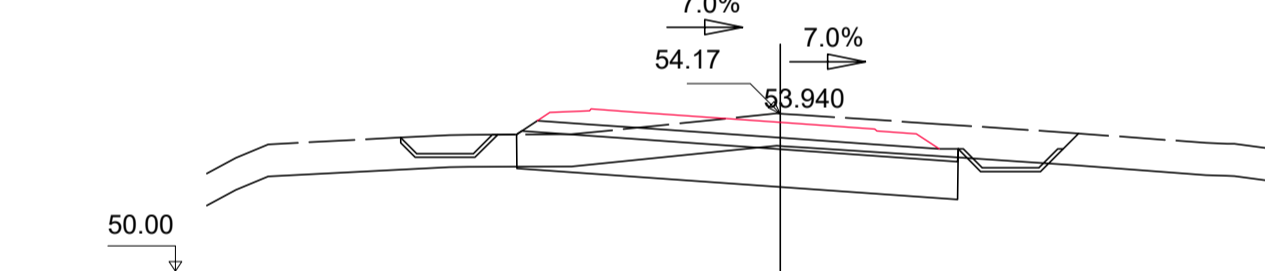

Pk=0+080
 S. FIRME = 3.96 m2. S. D TIERRA = 9.31 m2. S. SUELO ADEC = 11.67 m2. S. SUELO S-EST3 = 3.41 m2.
 S. REVES CUNETAS = 0.31 m2. S. TERRAPLEN = 1.41 m2. S. REV CUN GUARDA = 0.29 m2. S. VEGETAL = 14.91 m2.

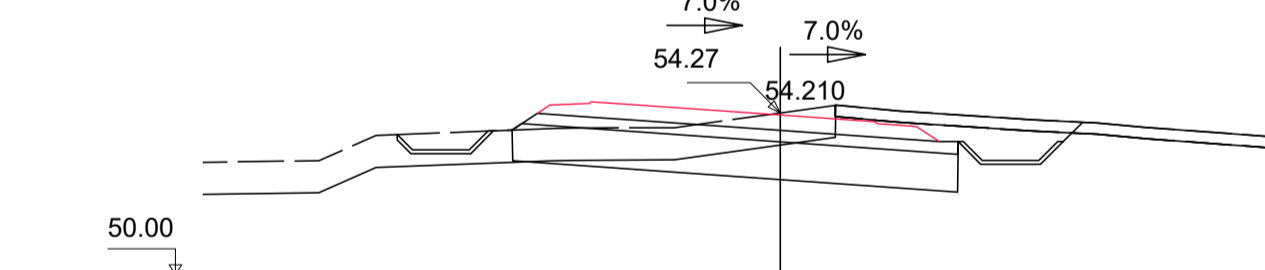

Pk=0+100
 S. FIRME = 3.96 m2. S. D TIERRA = 11.88 m2. S. SUELO ADEC = 11.76 m2. S. SUELO S-EST3 = 3.41 m2.
 S. REVES CUNETAS = 0.31 m2. S. TERRAPLEN = 1.44 m2. S. REV CUN GUARDA = 0.29 m2. S. VEGETAL = 9.85 m2.

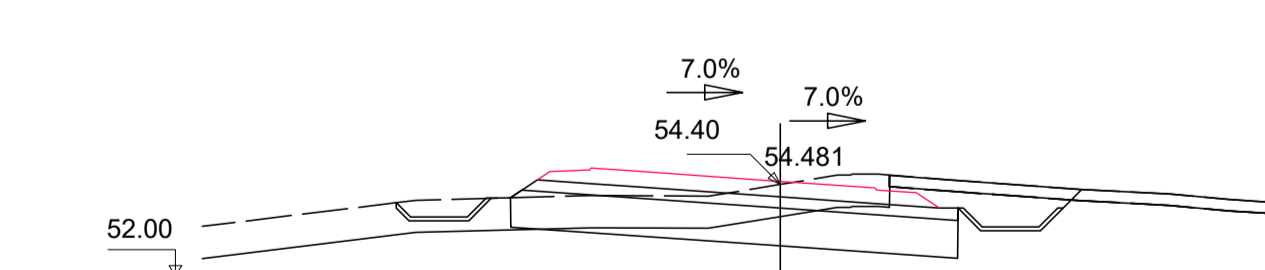

Pk=0+120
 S. FIRME = 3.96 m2. S. D TIERRA = 10.38 m2. S. SUELO ADEC = 11.80 m2. S. SUELO S-EST3 = 3.41 m2.
 S. REVES CUNETAS = 0.31 m2. S. TERRAPLEN = 1.42 m2. S. REV CUN GUARDA = 0.28 m2. S. VEGETAL = 11.09 m2.

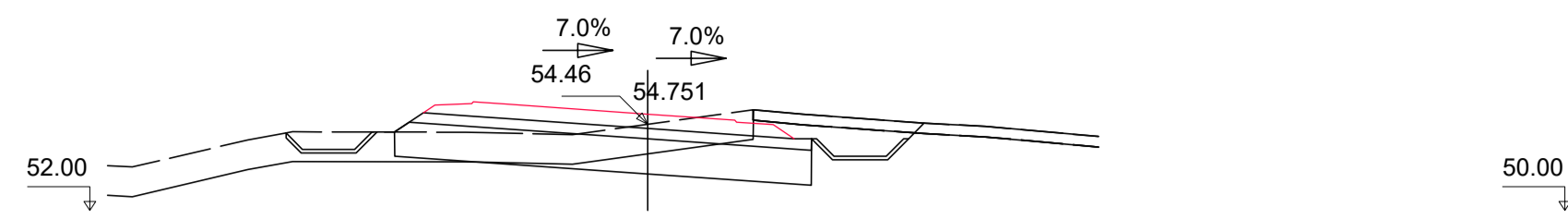

Pk=0+140
 S. FIRME = 3.96 m2. S. D TIERRA = 8.56 m2. S. SUELO ADEC = 11.89 m2. S. SUELO S-EST3 = 3.41 m2.
 S. REVES CUNETAS = 0.31 m2. S. TERRAPLEN = 1.54 m2. S. REV CUN GUARDA = 0.30 m2. S. VEGETAL = 11.39 m2.

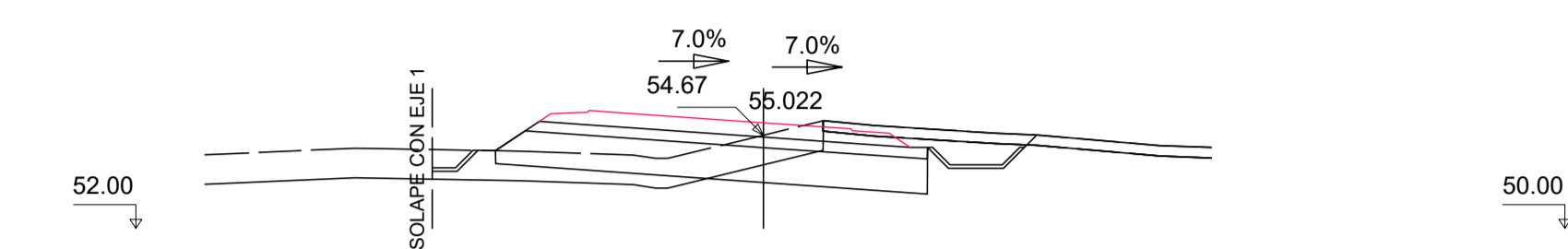

Pk=0+160
 S. FIRME = 3.96 m2. S. D TIERRA = 8.12 m2. S. SUELO ADEC = 12.12 m2. S. SUELO S-EST3 = 3.41 m2.
 S. REVES CUNETAS = 0.31 m2. S. TERRAPLEN = 3.04 m2. S. REV CUN GUARDA = 0.15 m2. S. VEGETAL = 9.53 m2.

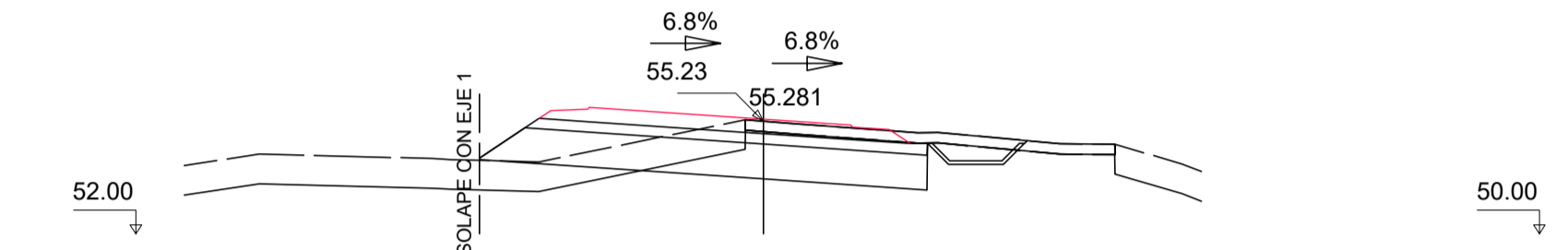

Pk=0+180
 S. FIRME = 3.96 m2. S. D TIERRA = 9.30 m2. S. SUELO ADEC = 12.22 m2. S. SUELO S-EST3 = 3.41 m2.
 S. REVES CUNETAS = 0.31 m2. S. TERRAPLEN = 2.60 m2. S. REV CUN GUARDA = 0.15 m2. S. VEGETAL = 6.47 m2.

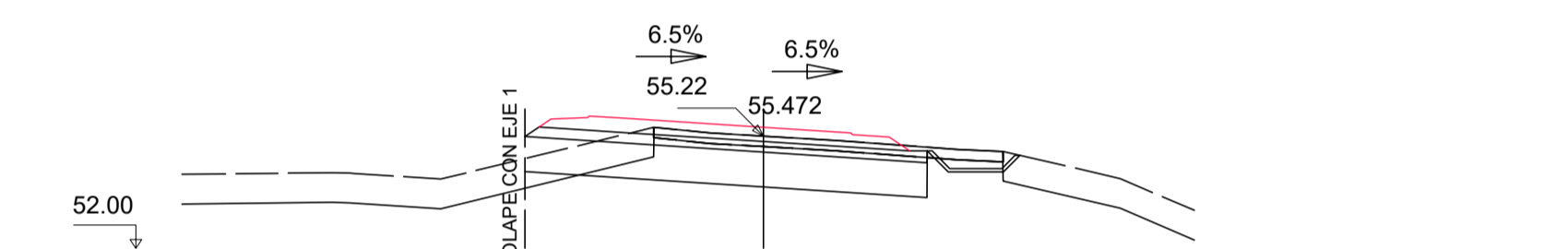

Pk=0+200
 S. FIRME = 3.96 m2. S. D TIERRA = 10.40 m2. S. SUELO ADEC = 11.54 m2. S. SUELO S-EST3 = 3.41 m2.
 S. REVES CUNETAS = 0.29 m2. S. TERRAPLEN = 0.38 m2. S. REV CUN GUARDA = 0.27 m2. S. VEGETAL = 3.29 m2.

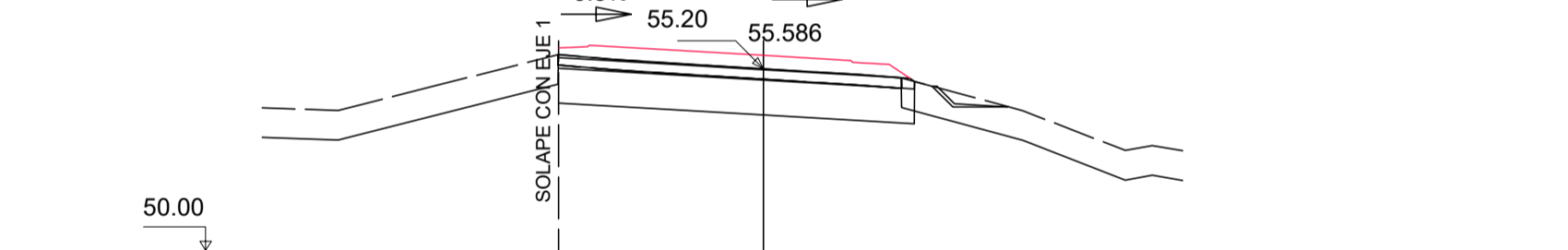

Pk=0+220
 S. FIRME = 3.86 m2. S. D TIERRA = 10.30 m2. S. SUELO ADEC = 10.20 m2. S. SUELO S-EST3 = 3.06 m2.
 S. TERRAPLEN = 1.80 m2. S. REV CUN GUARDA = 0.16 m2. S. VEGETAL = 2.60 m2. S. DEMOLICION = 2.95 m2.

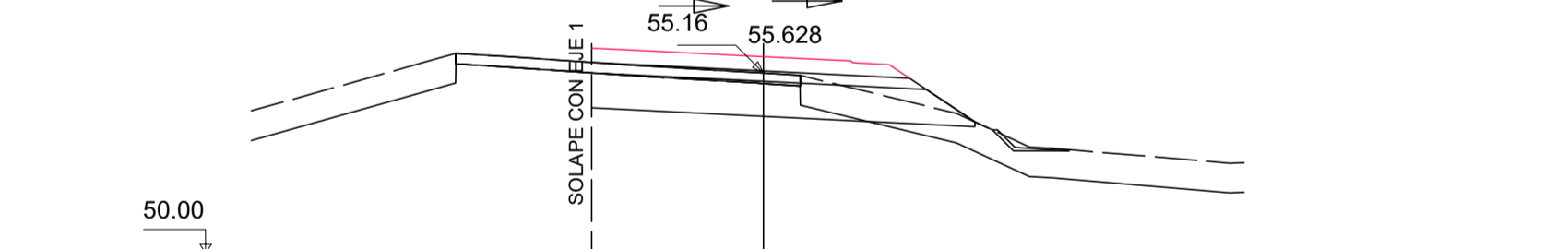

Pk=0+240
 S. FIRME = 3.55 m2. S. D TIERRA = 6.11 m2. S. SUELO ADEC = 10.40 m2. S. SUELO S-EST3 = 2.81 m2.
 S. TERRAPLEN = 2.97 m2. S. REV CUN GUARDA = 0.16 m2. S. VEGETAL = 6.57 m2. S. DEMOLICION = 1.80 m2.

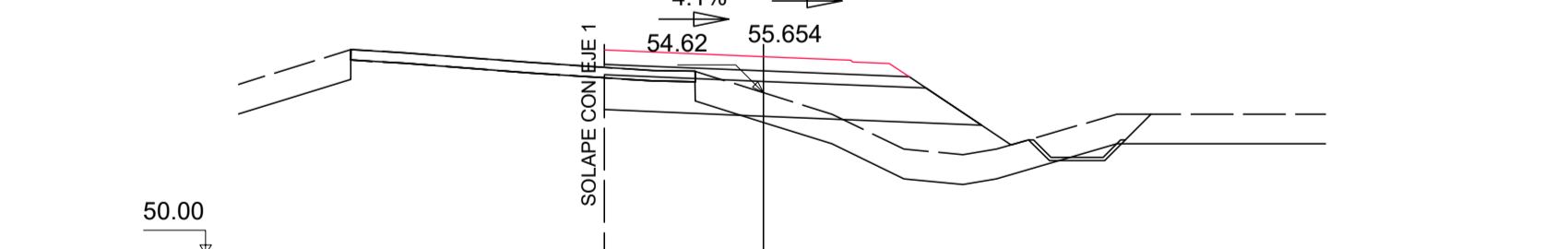

Pk=0+260
 S. FIRME = 3.40 m2. S. D TIERRA = 2.91 m2. S. SUELO ADEC = 10.03 m2. S. SUELO S-EST3 = 2.70 m2.
 S. TERRAPLEN = 9.20 m2. S. REV CUN GUARDA = 0.31 m2. S. VEGETAL = 11.11 m2. S. DEMOLICION = 0.78 m2.

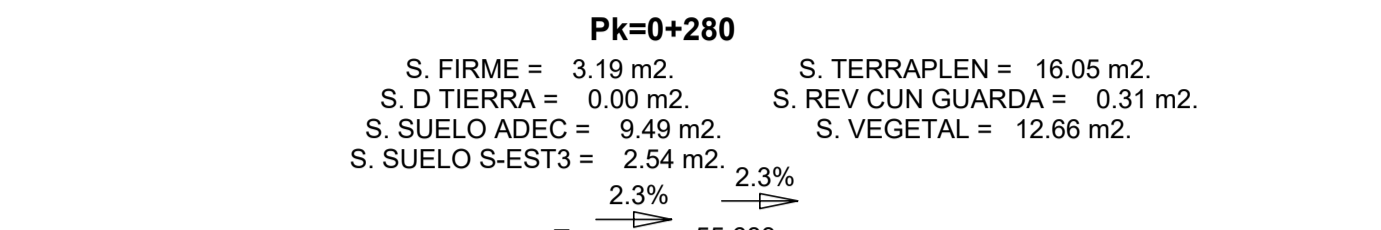

Pk=0+280
 S. FIRME = 3.19 m2. S. D TIERRA = 0.00 m2. S. SUELO ADEC = 9.49 m2. S. SUELO S-EST3 = 2.54 m2.
 S. TERRAPLEN = 16.05 m2. S. REV CUN GUARDA = 0.31 m2. S. VEGETAL = 12.66 m2.



Pk=0+300
 S. FIRME = 2.96 m2. S. D TIERRA = 8.92 m2. S. SUELO ADEC = 20.57 m2. S. SUELO S-EST3 = 2.37 m2.
 S. TERRAPLEN = 20.57 m2. S. REV CUN GUARDA = 0.30 m2. S. VEGETAL = 12.19 m2.



Pk=0+306.828
 S. FIRME = 2.94 m2. S. D TIERRA = 8.87 m2. S. SUELO ADEC = 2.36 m2. S. SUELO S-EST3 = 2.36 m2.
 S. TERRAPLEN = 20.02 m2. S. REV CUN GUARDA = 0.30 m2. S. VEGETAL = 11.99 m2.

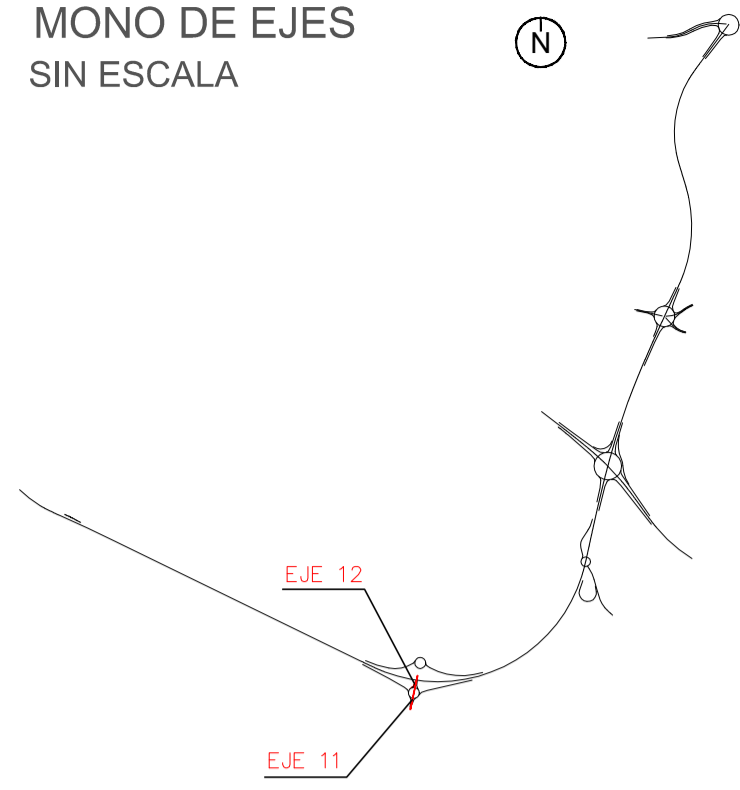

EJE 11

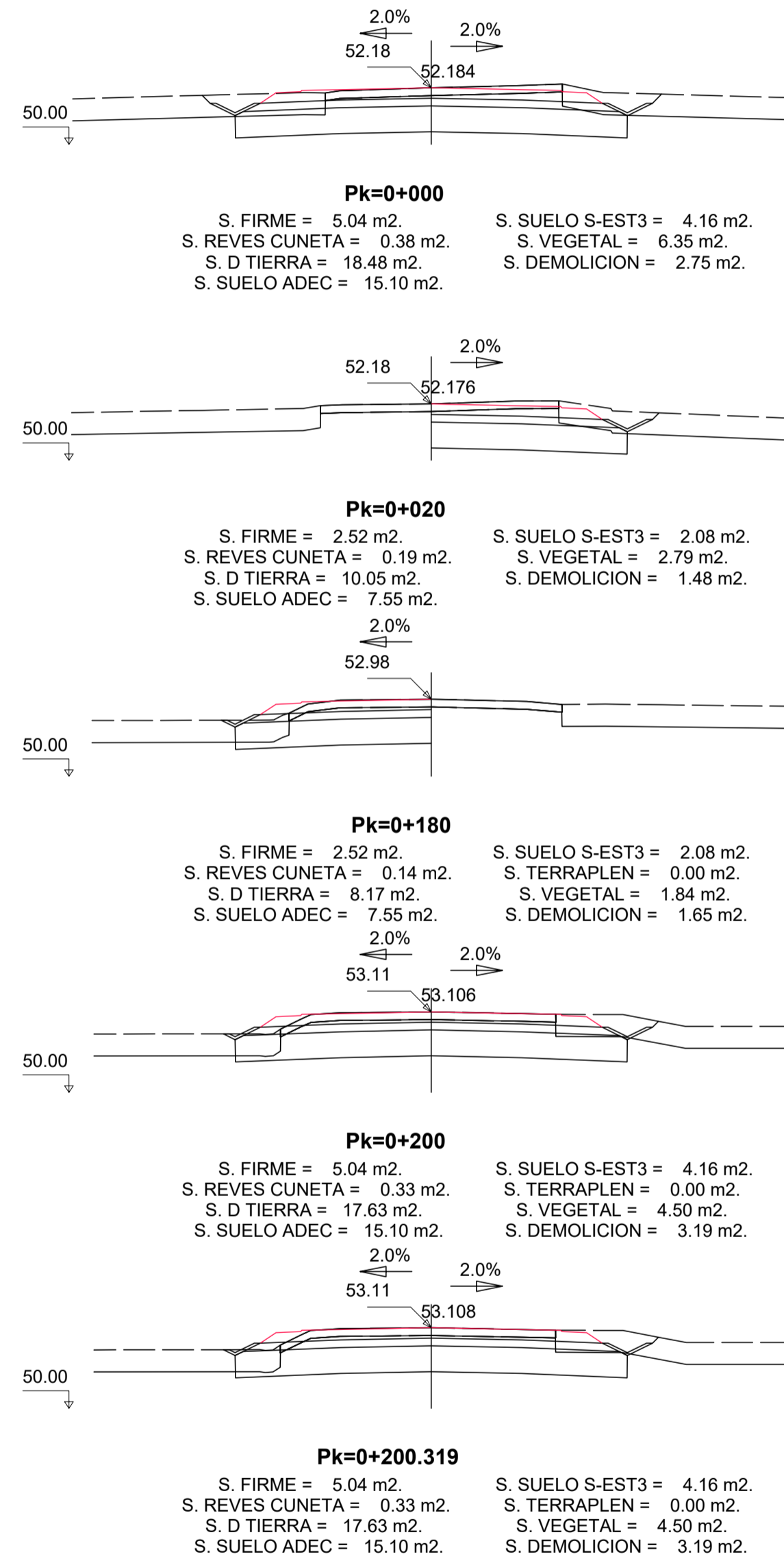

EJE 12

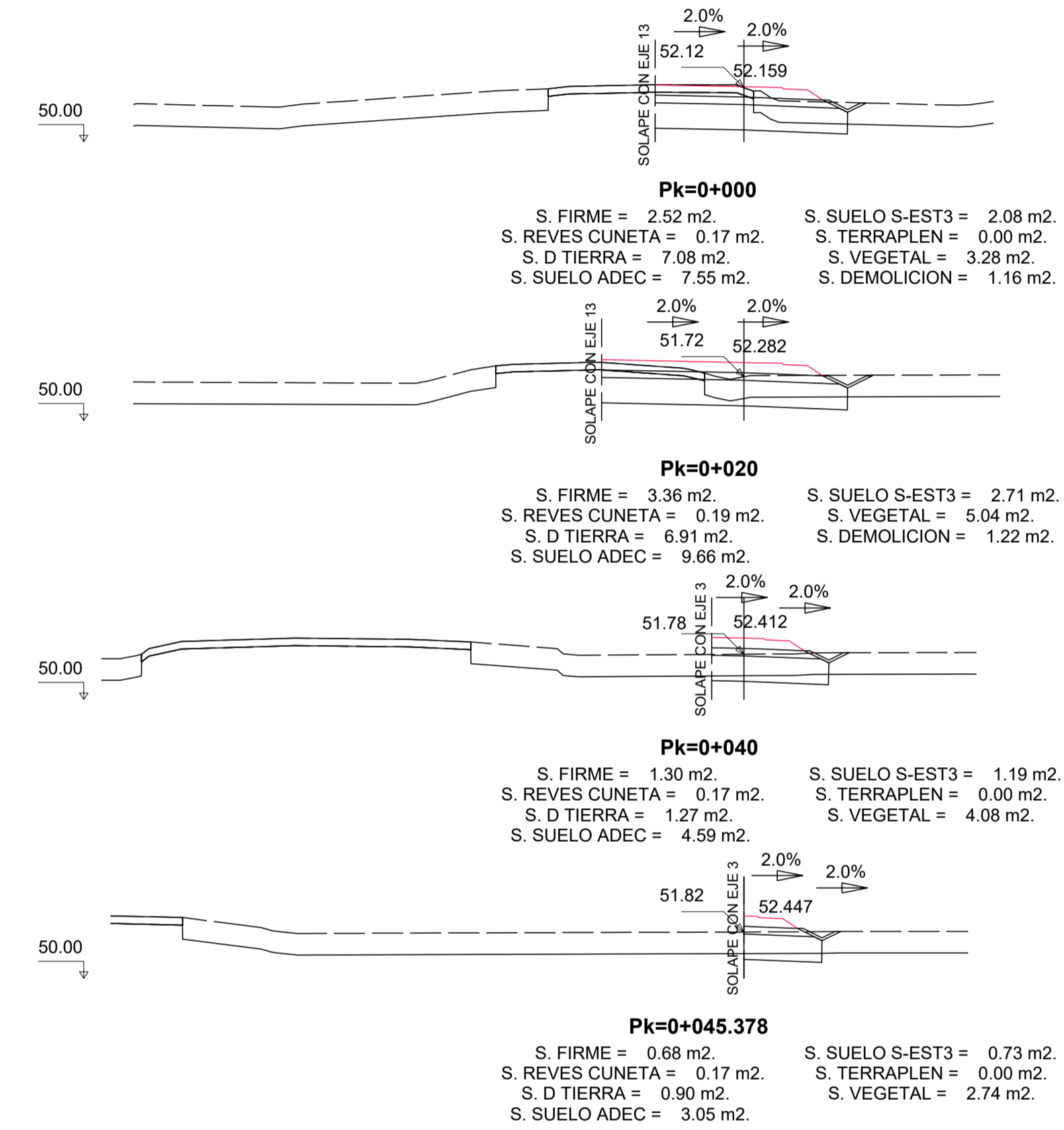

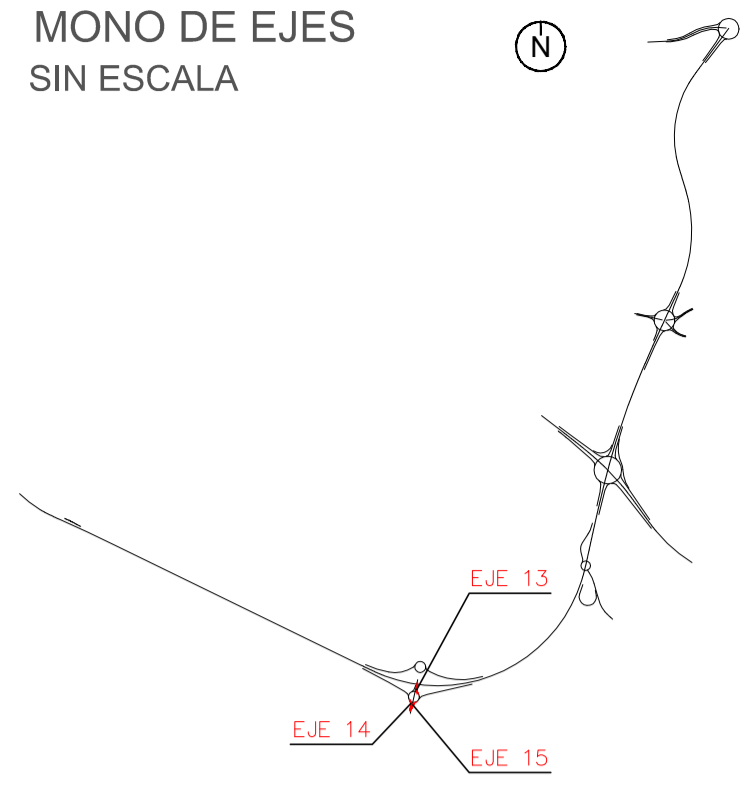

EJE 13

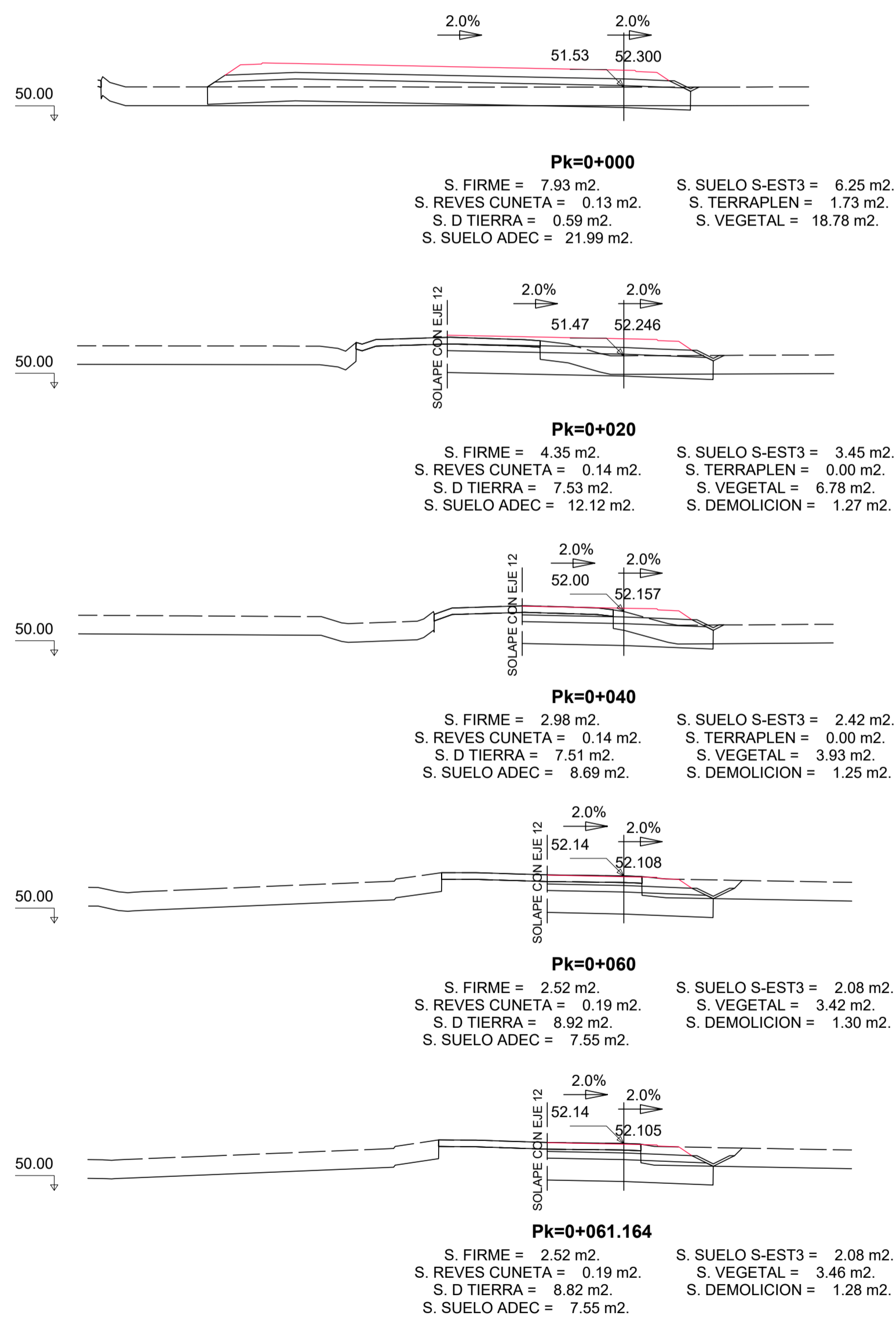

EJE 14

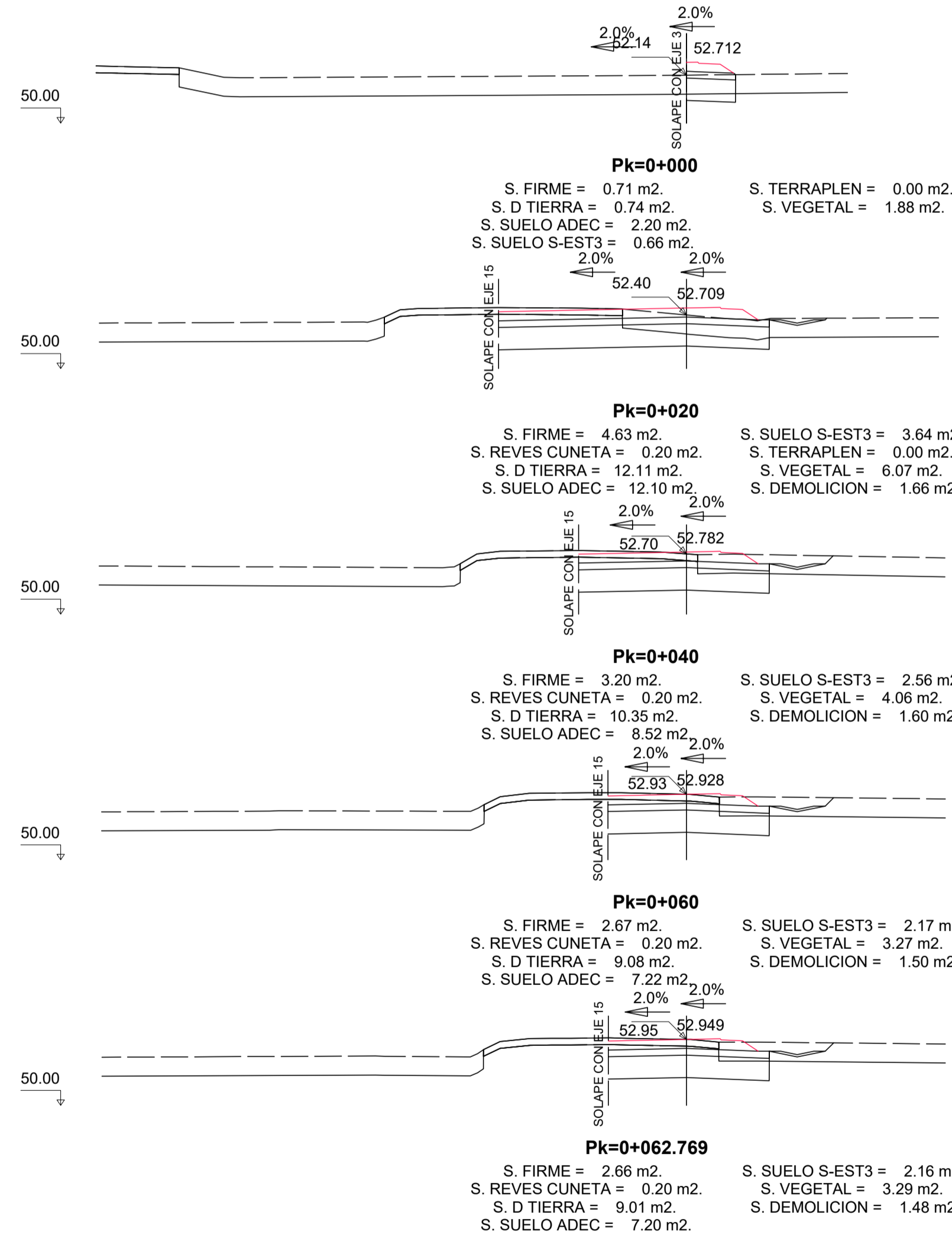

EJE 15

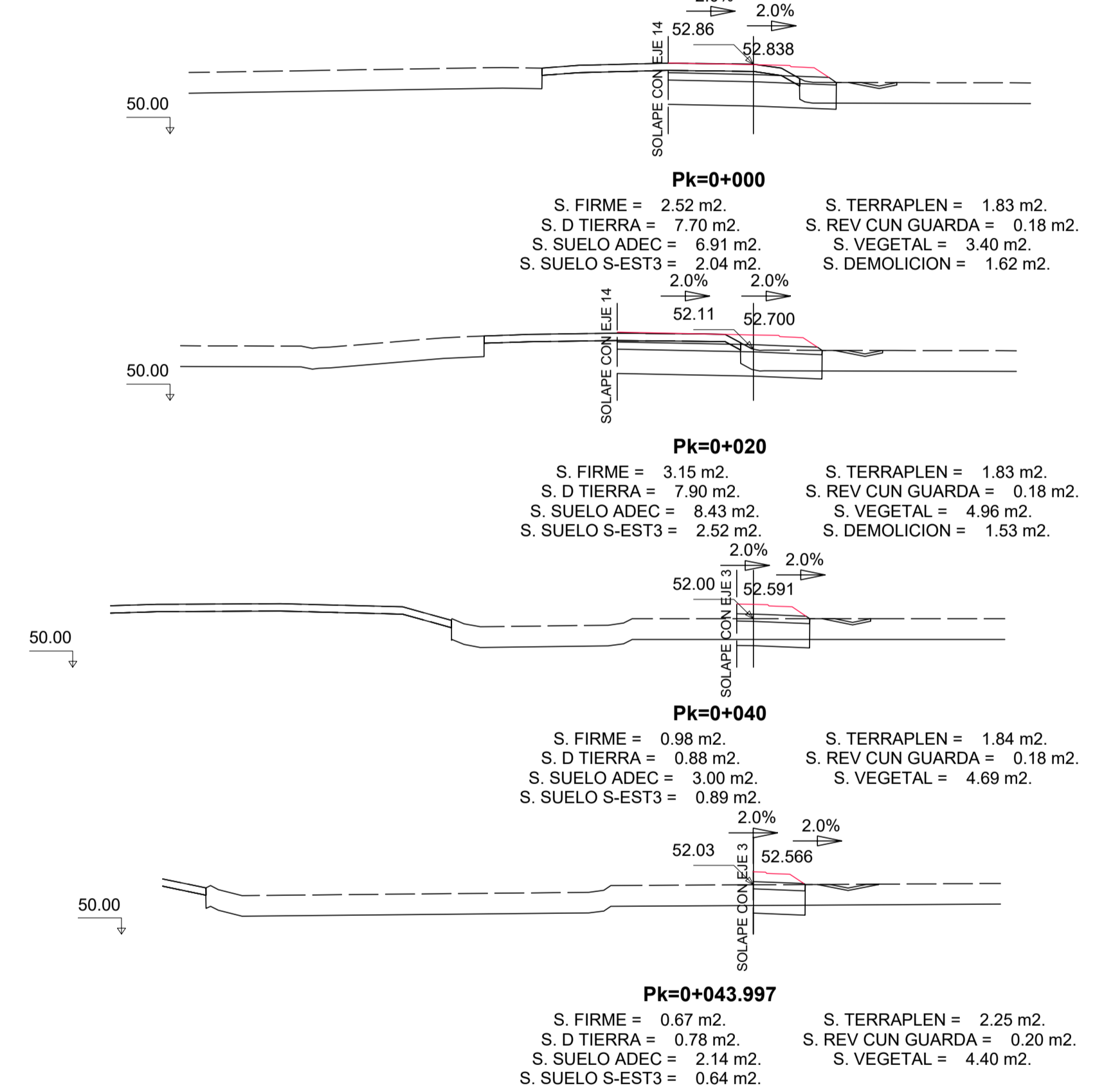

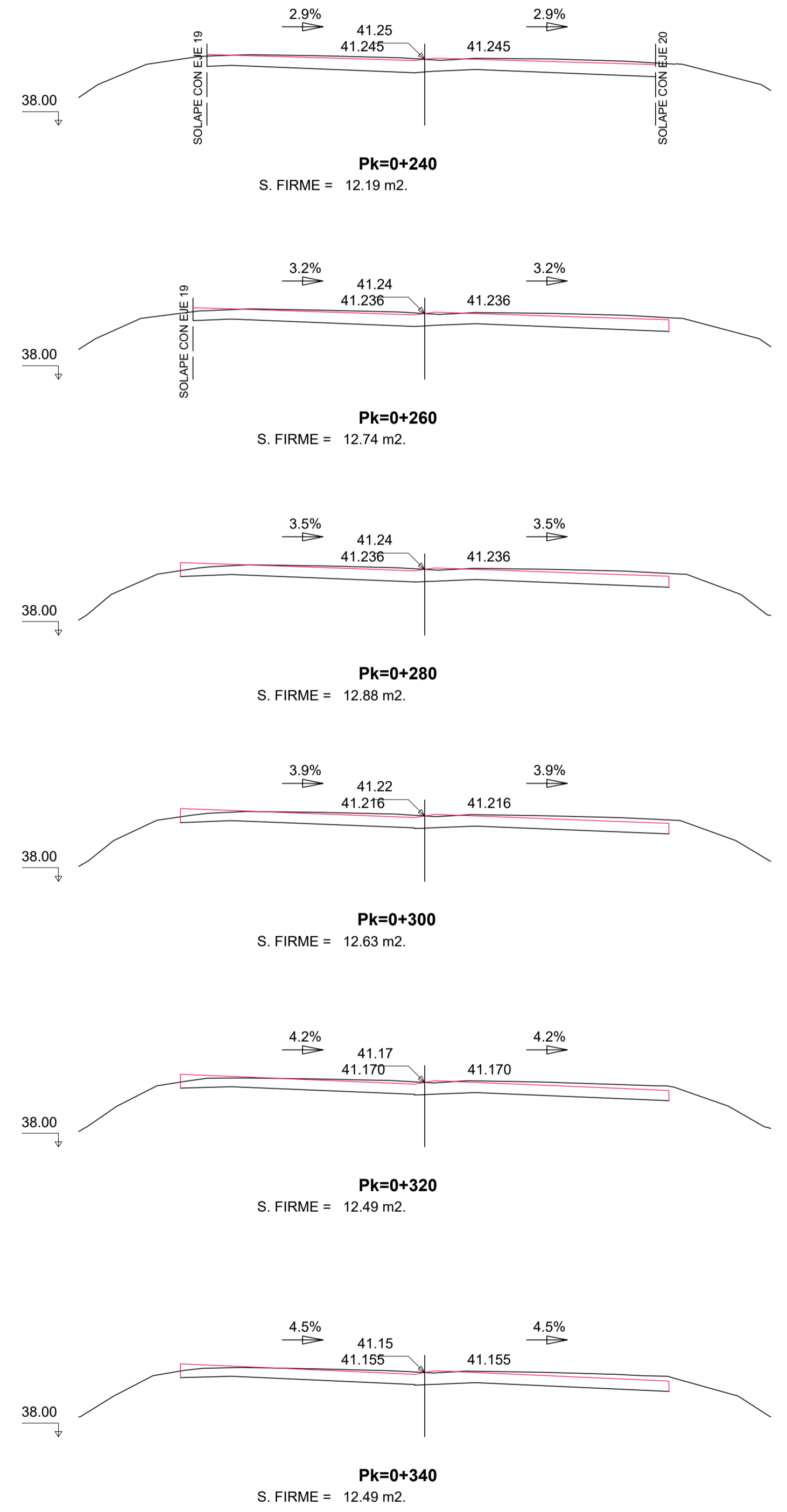
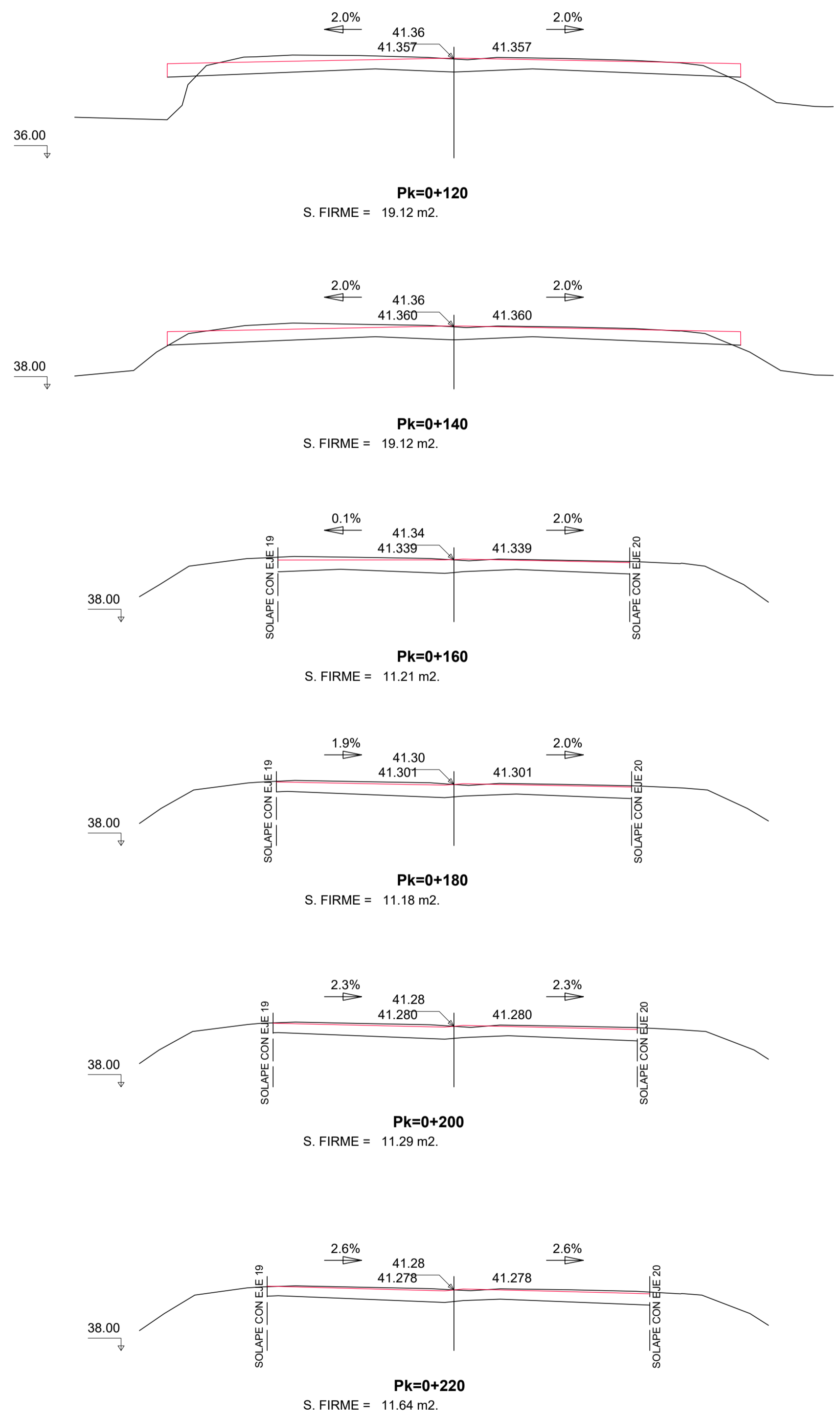
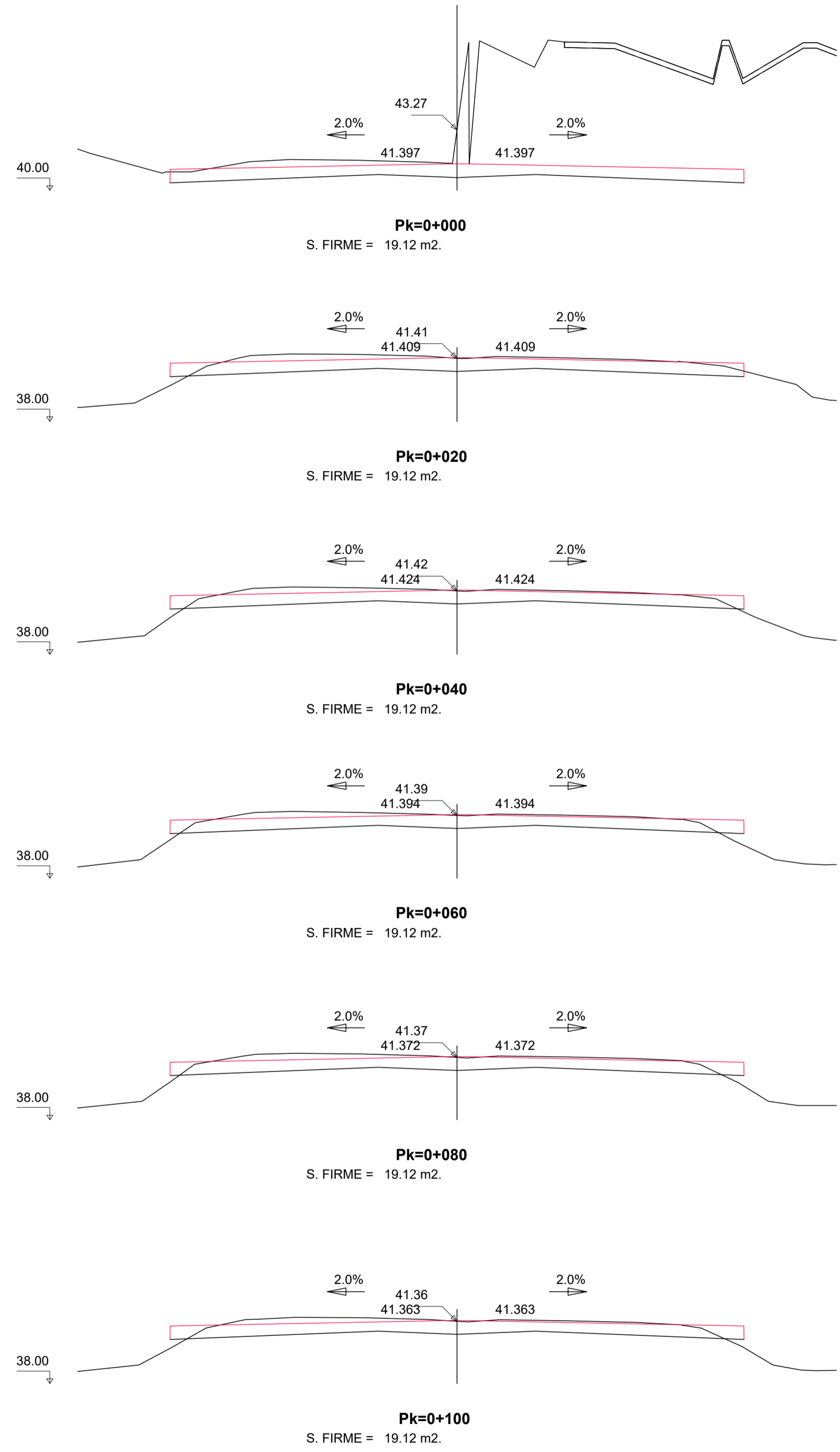
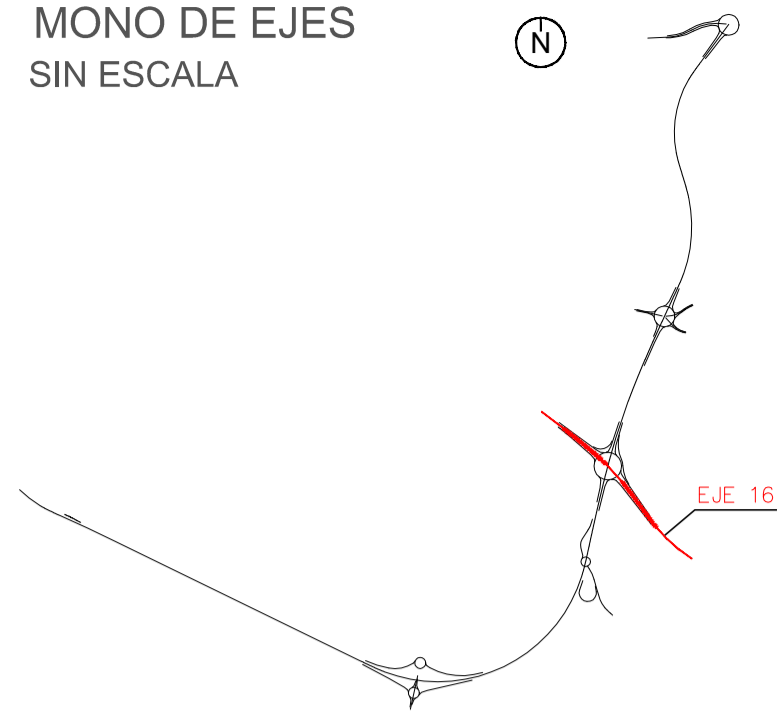

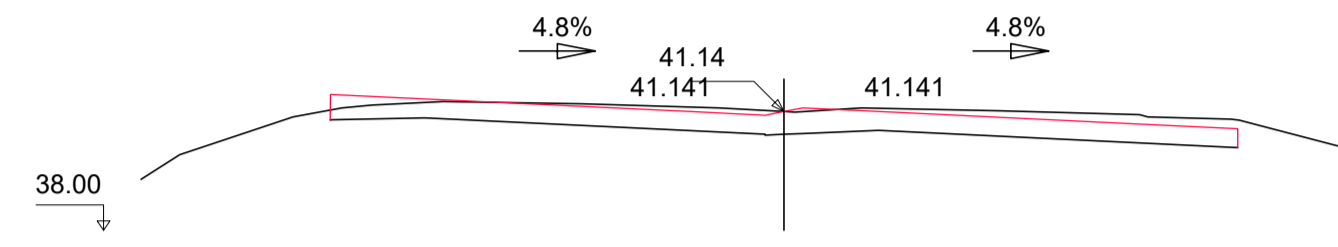
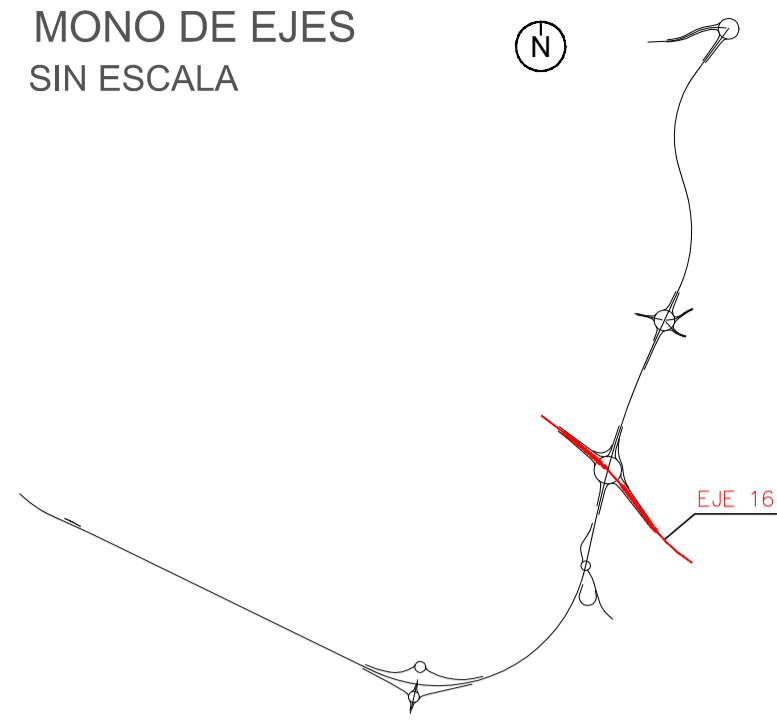

Pk=0+360
S. FIRME = 12.50 m2.

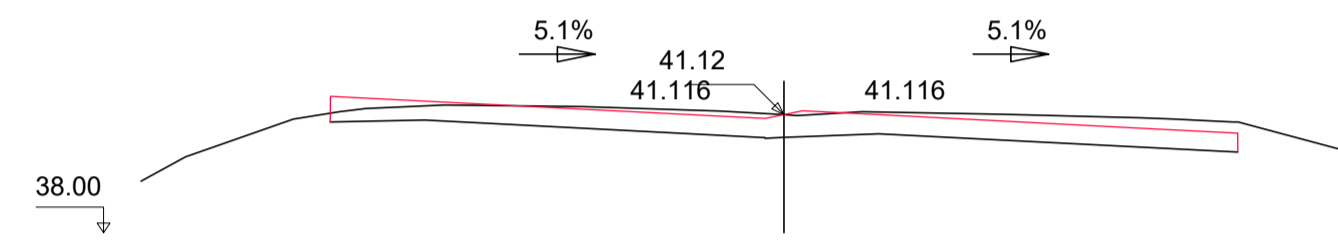

Pk=0+380
S. FIRME = 12.50 m2.

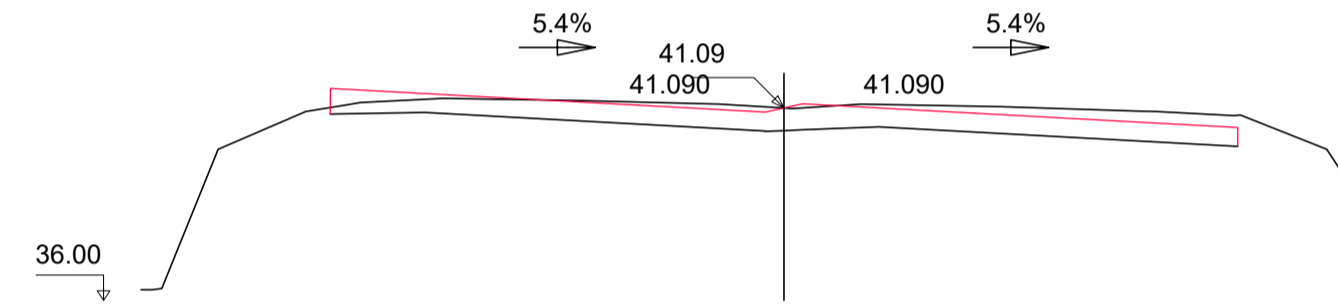

Pk=0+400
S. FIRME = 12.51 m2.

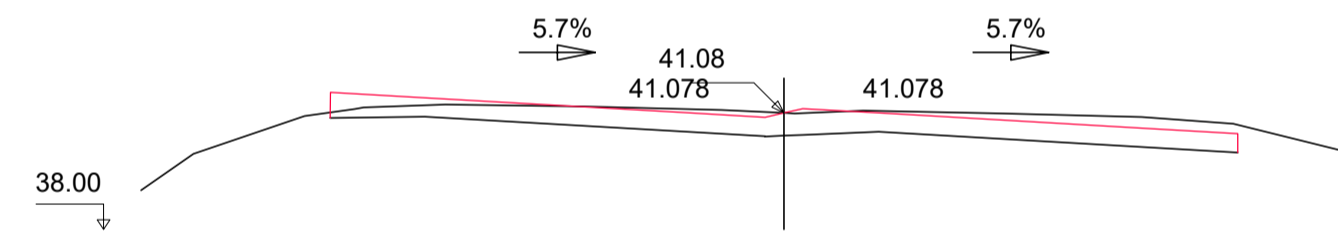

Pk=0+420
S. FIRME = 12.52 m2.

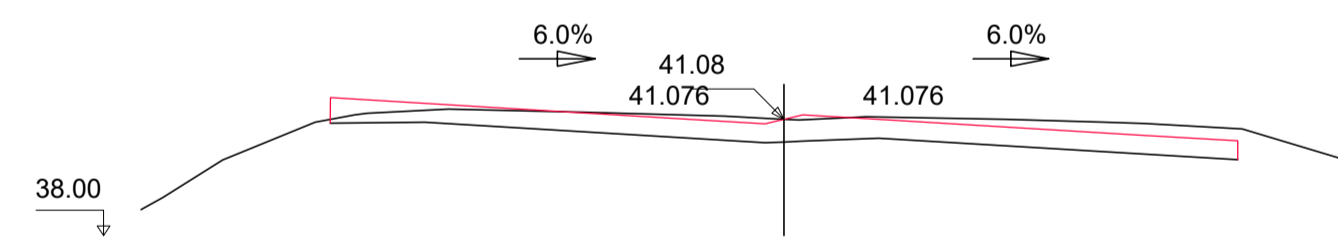

Pk=0+440
S. FIRME = 12.52 m2.

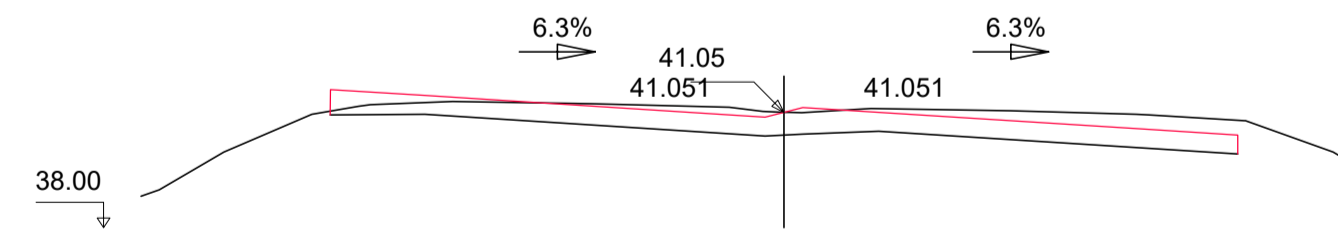

Pk=0+460
S. FIRME = 12.53 m2.

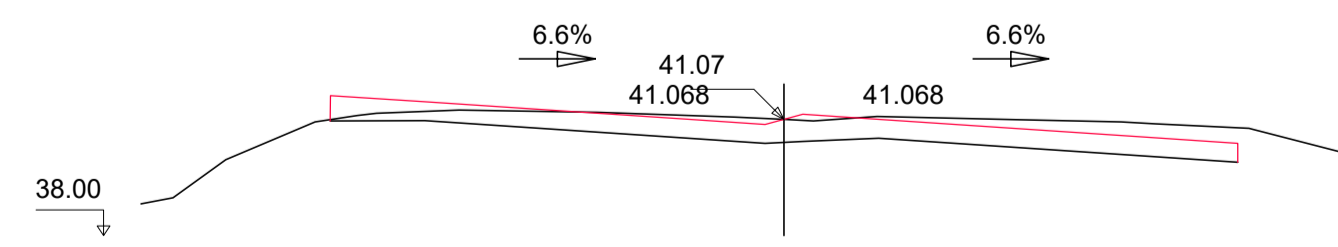

Pk=0+480
S. FIRME = 12.54 m2.

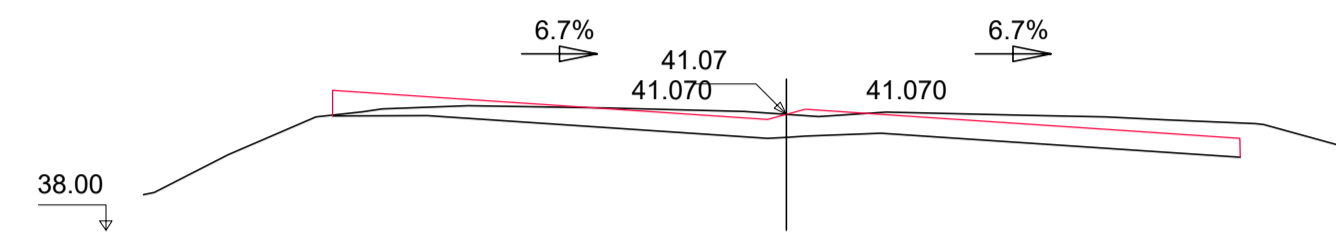

Pk=0+500
S. FIRME = 12.54 m2.

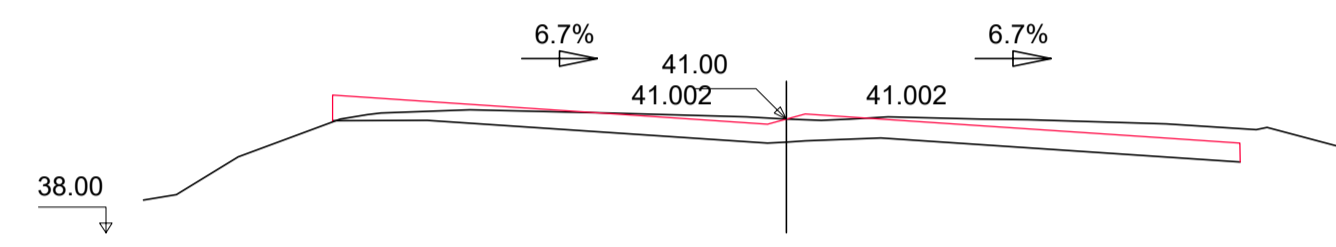

Pk=0+520
S. FIRME = 12.54 m2.

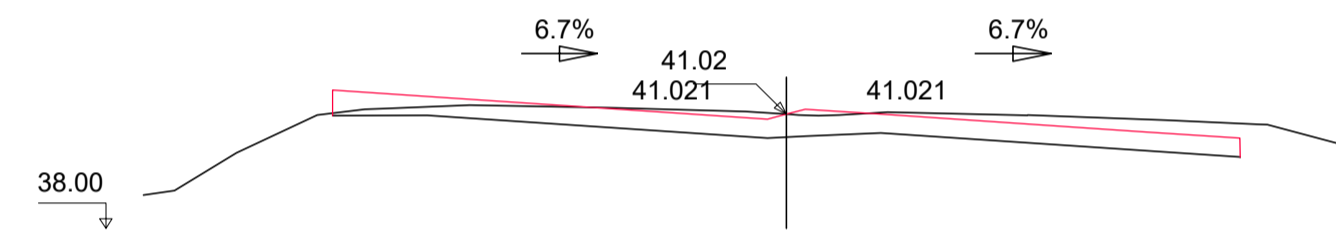

Pk=0+540
S. FIRME = 12.54 m2.

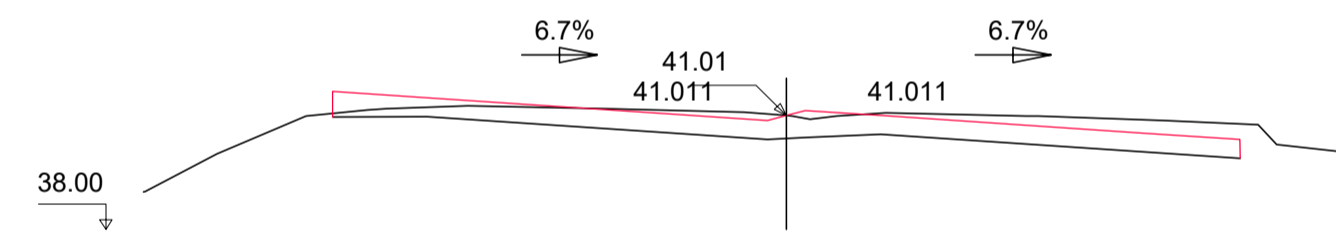

Pk=0+560
S. FIRME = 12.54 m2.

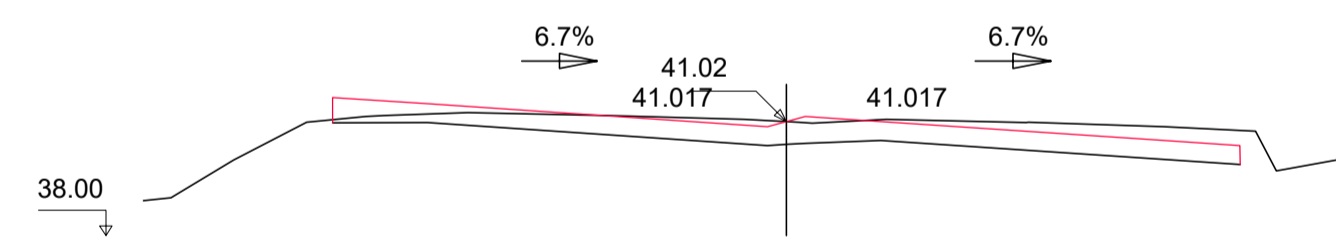

Pk=0+580
S. FIRME = 12.54 m2.

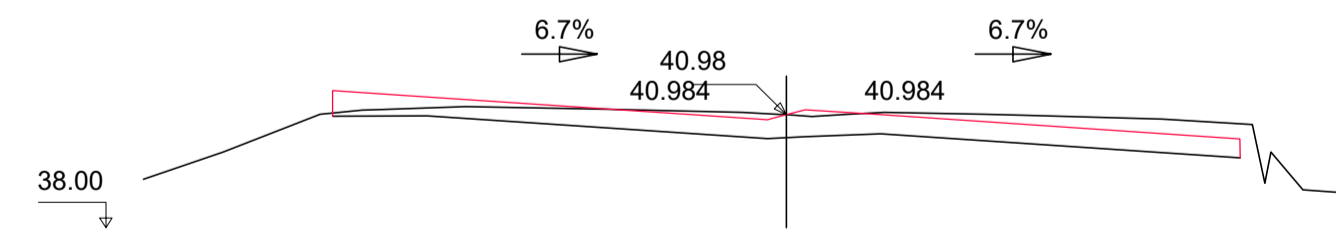

Pk=0+600
S. FIRME = 12.54 m2.

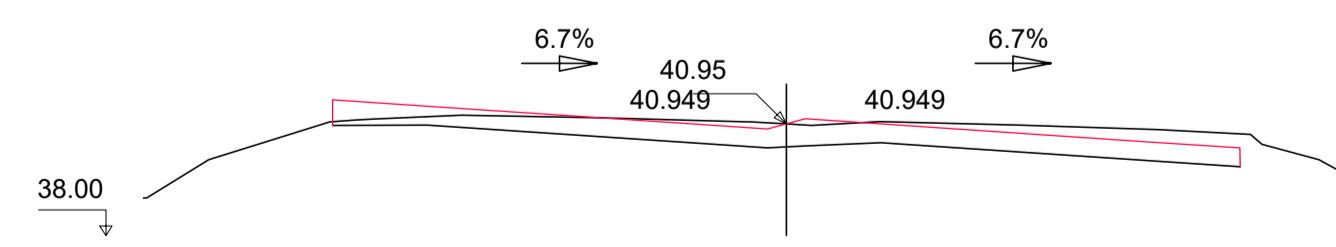

Pk=0+620
S. FIRME = 12.54 m2.

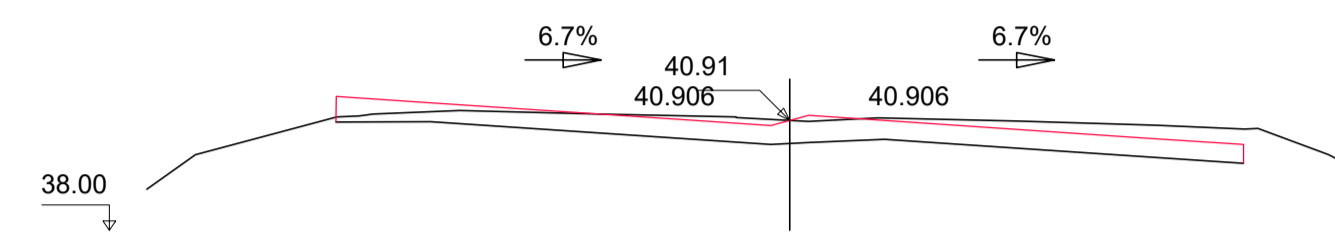

Pk=0+640
S. FIRME = 12.54 m2.

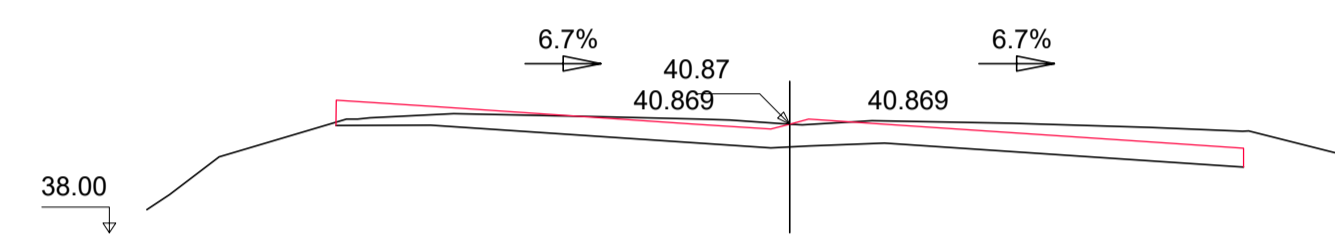

Pk=0+660
S. FIRME = 12.54 m2.

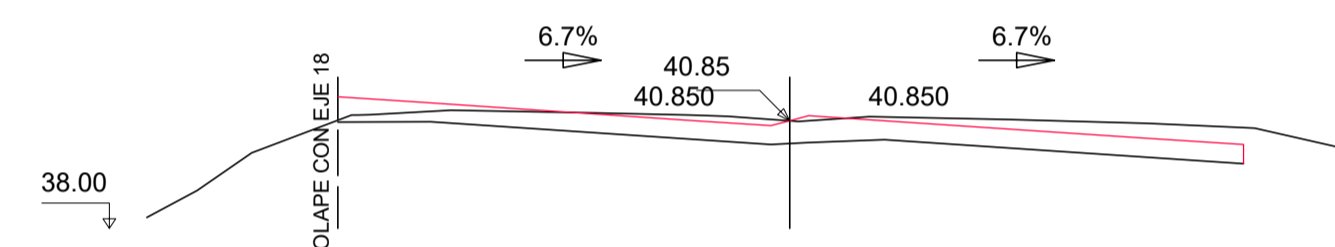

Pk=0+680
S. FIRME = 12.51 m2.

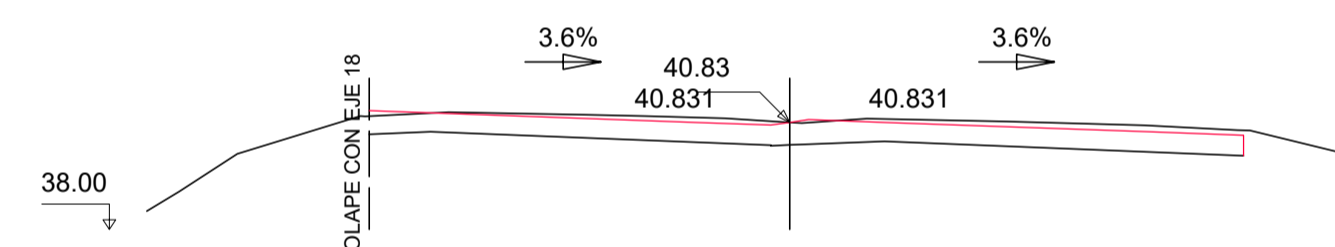

Pk=0+700
S. FIRME = 12.27 m2.

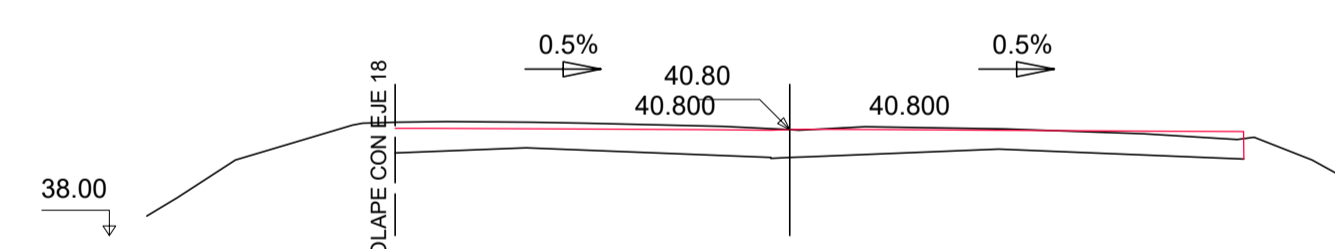

Pk=0+720
S. FIRME = 13.76 m2.

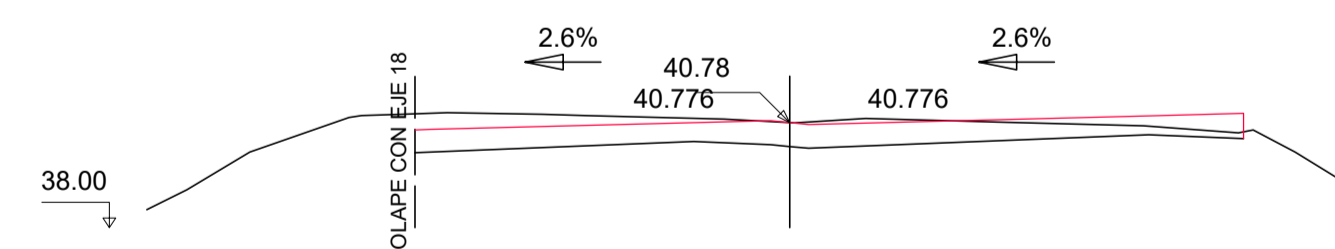

Pk=0+740
S. FIRME = 12.39 m2.

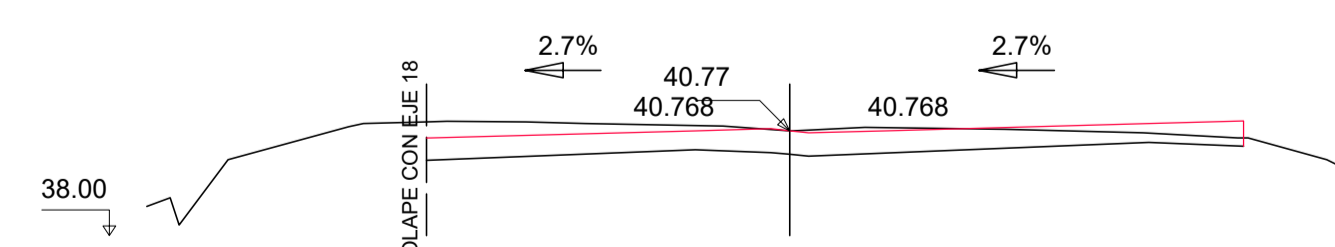

Pk=0+760
S. FIRME = 12.12 m2.

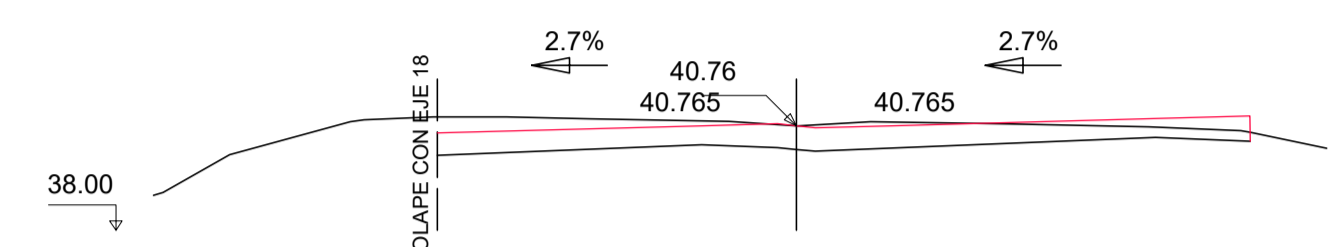

Pk=0+780
S. FIRME = 12.05 m2.

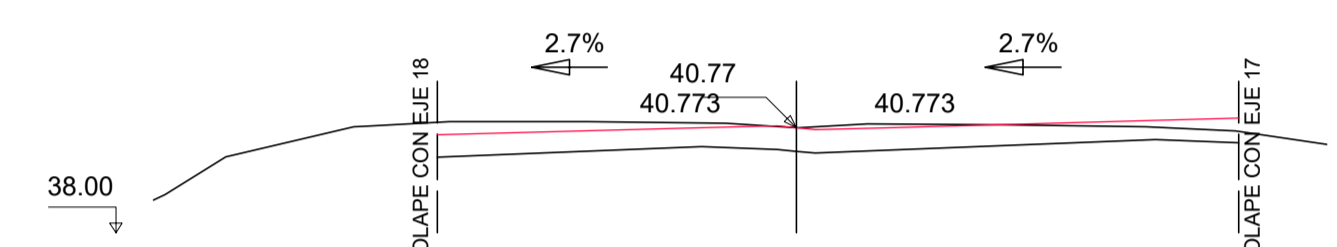

Pk=0+800
S. FIRME = 11.85 m2.

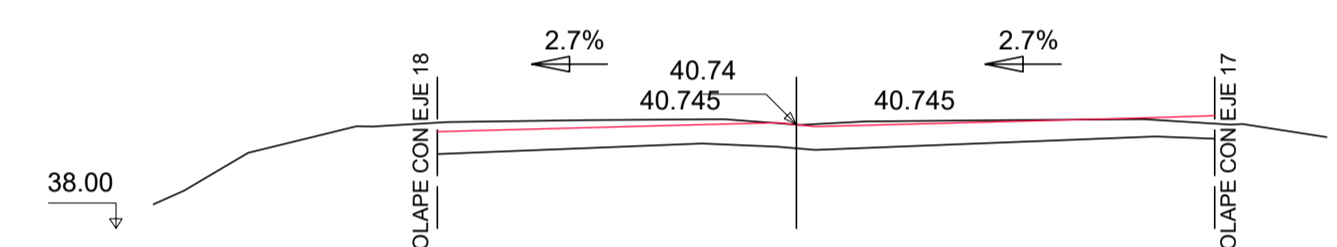

Pk=0+820
S. FIRME = 11.46 m2.

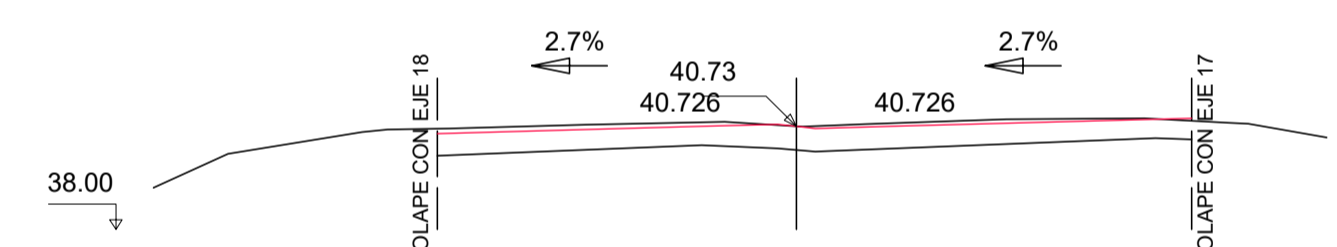

Pk=0+840
S. FIRME = 11.10 m2.

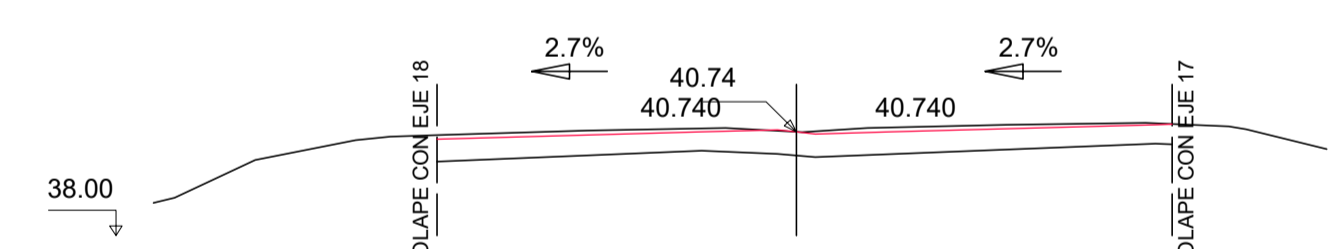

Pk=0+860
S. FIRME = 10.82 m2.

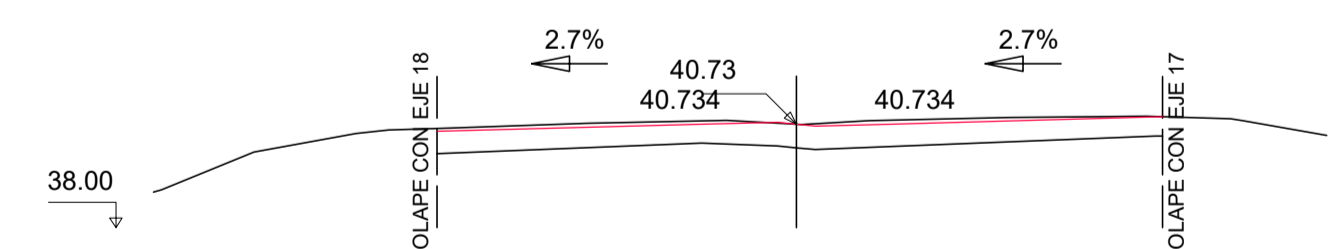

Pk=0+880
S. FIRME = 10.68 m2.

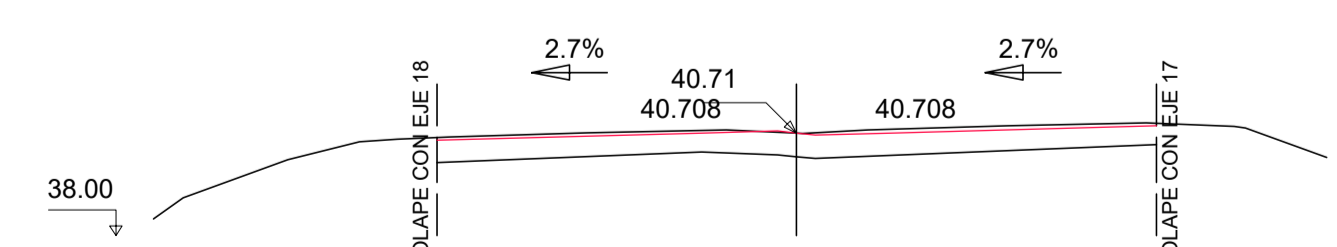

Pk=0+900
S. FIRME = 10.61 m2.

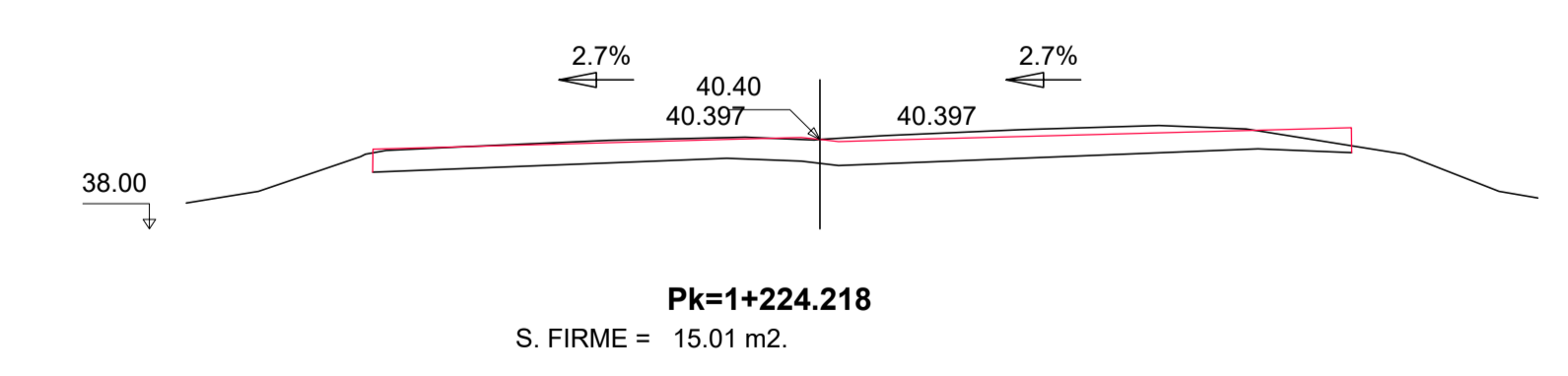
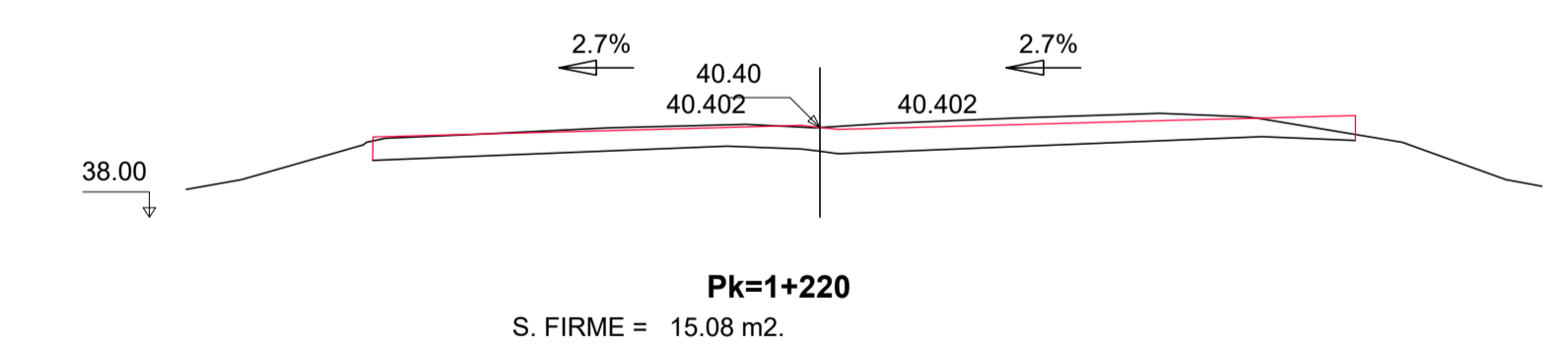
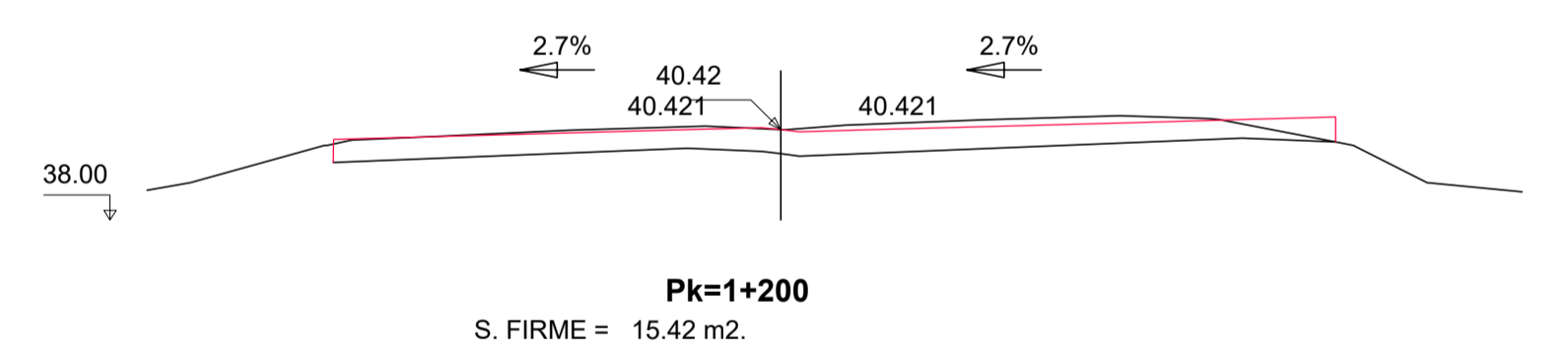
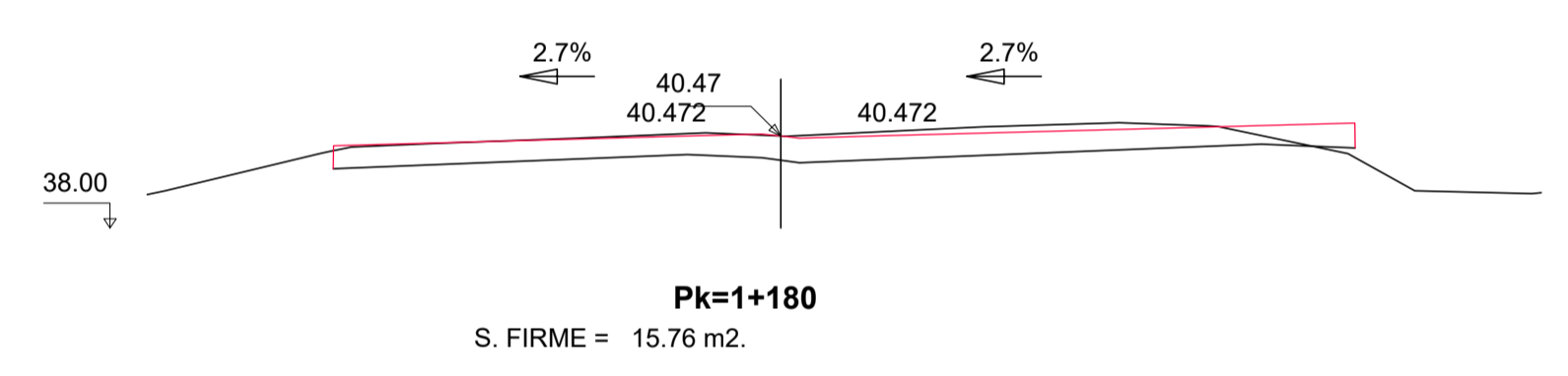
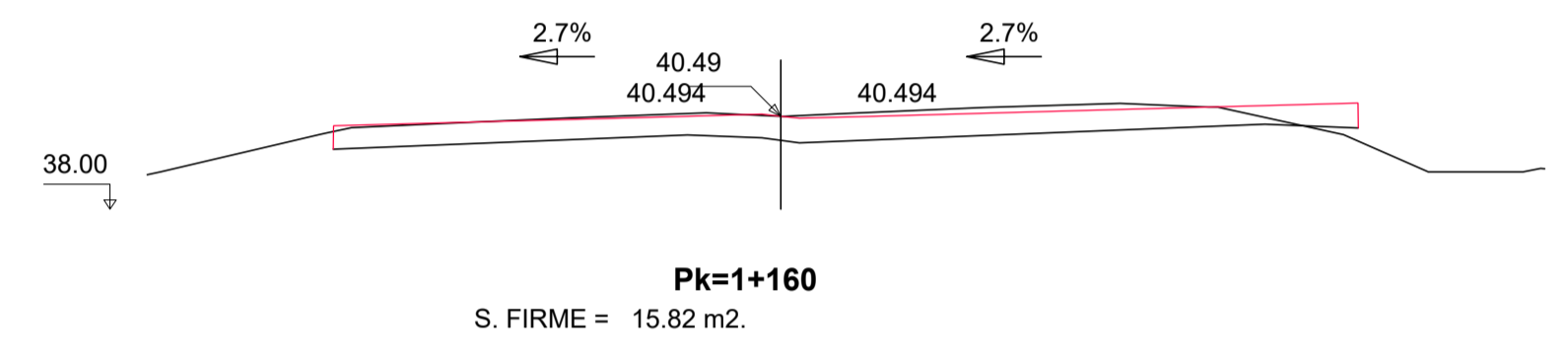
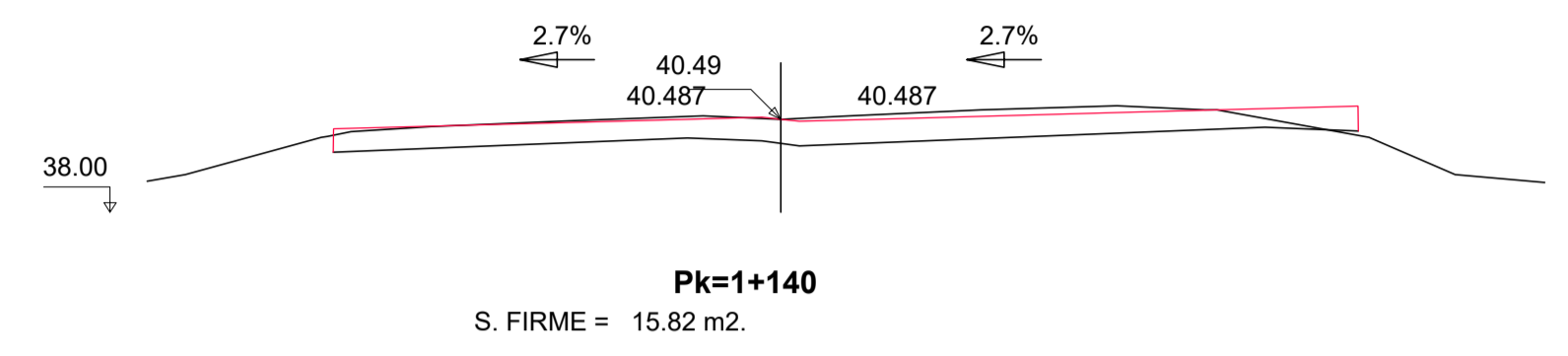
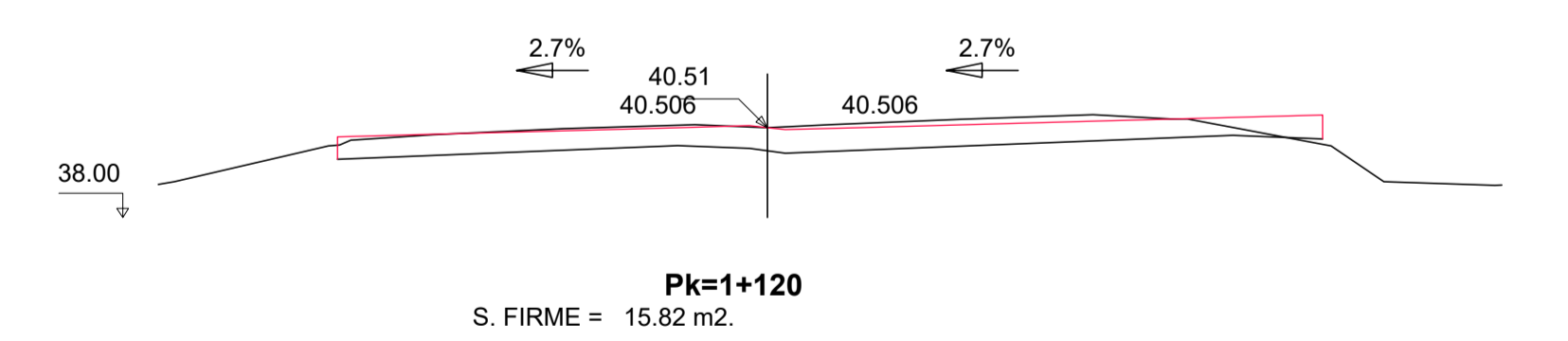
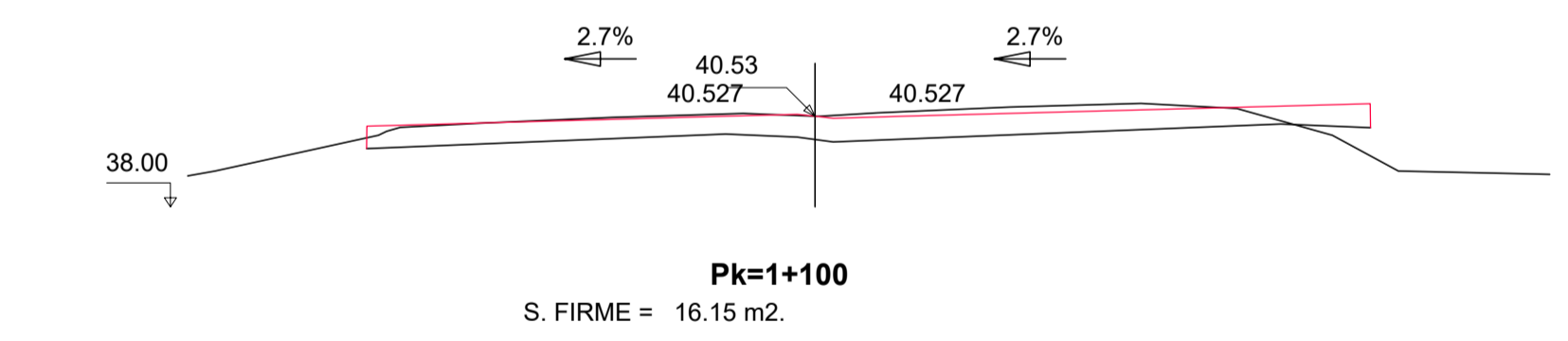
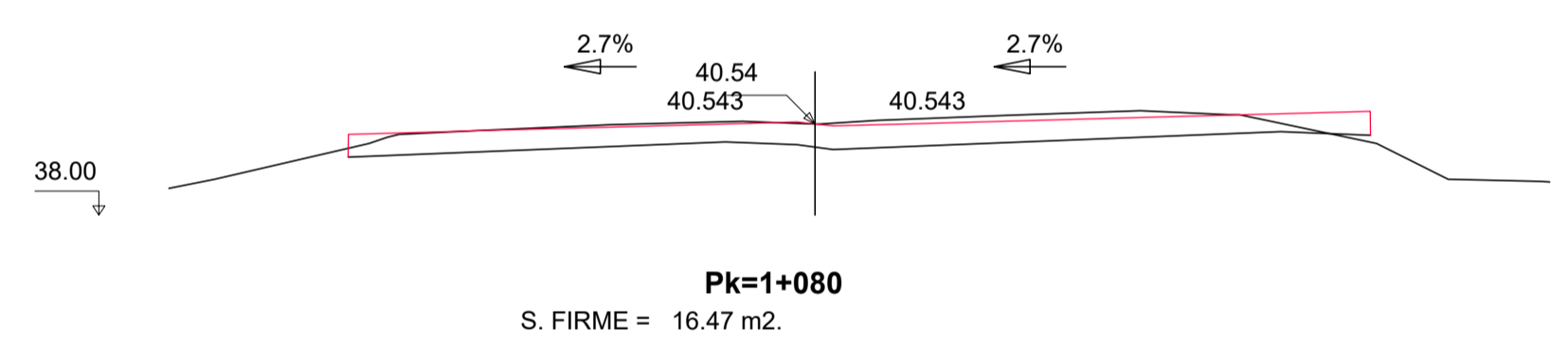
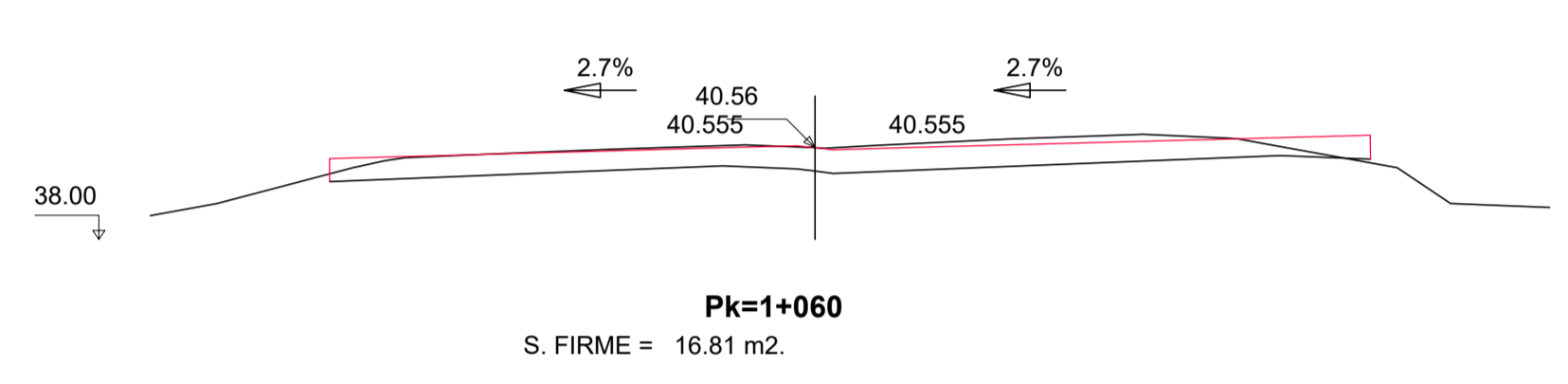
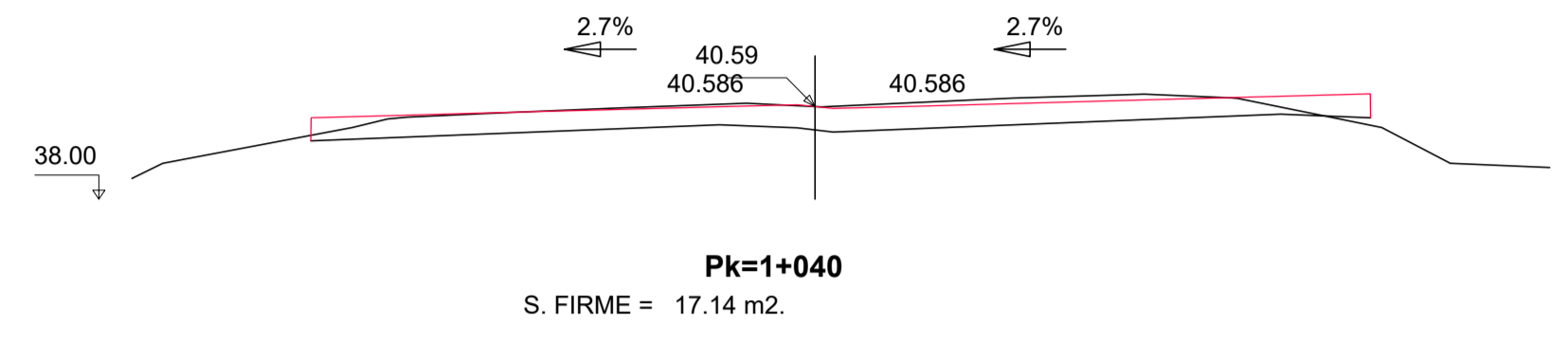
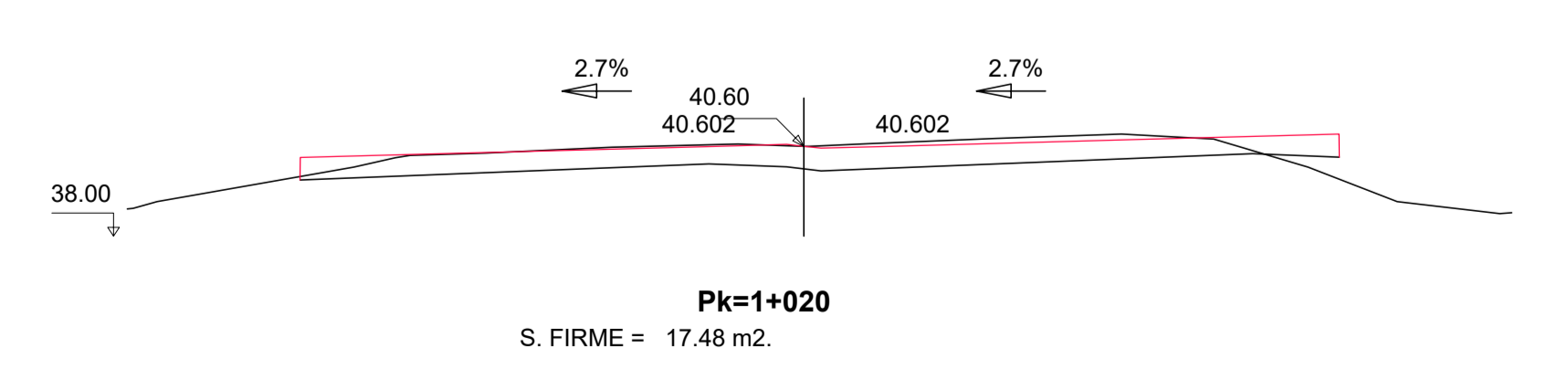
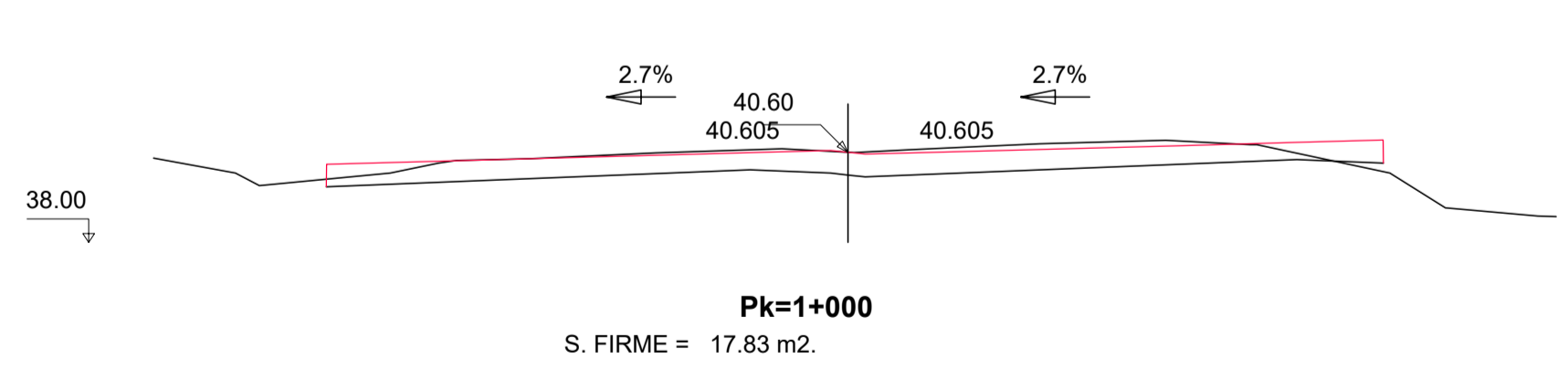
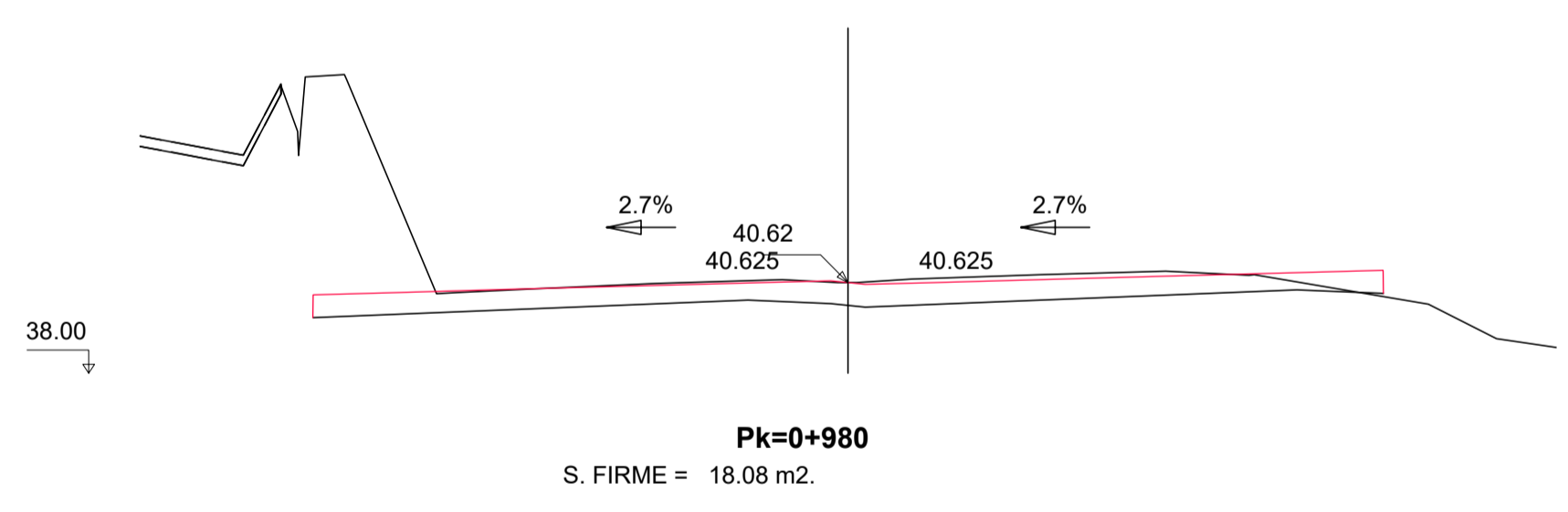
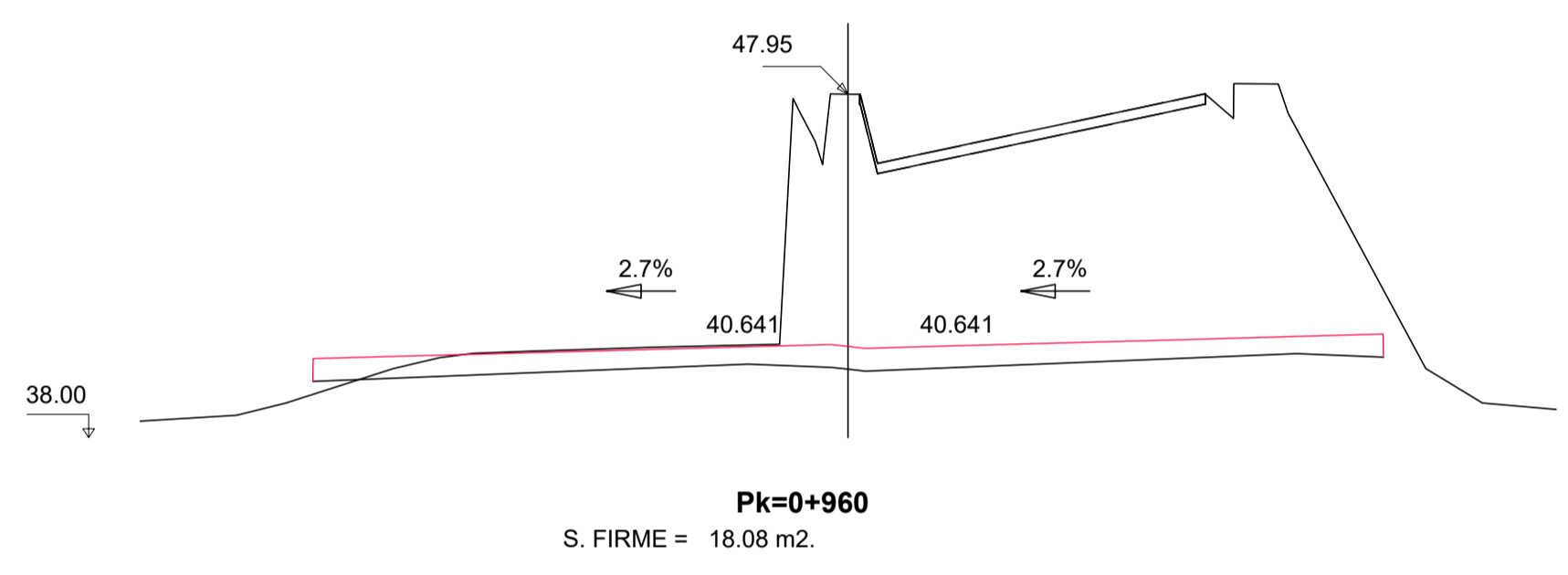
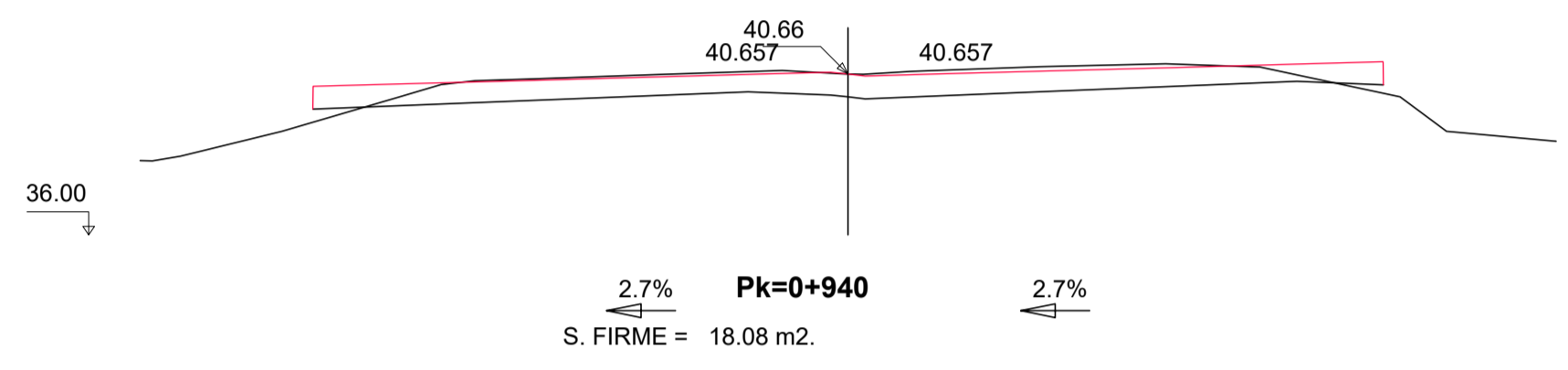
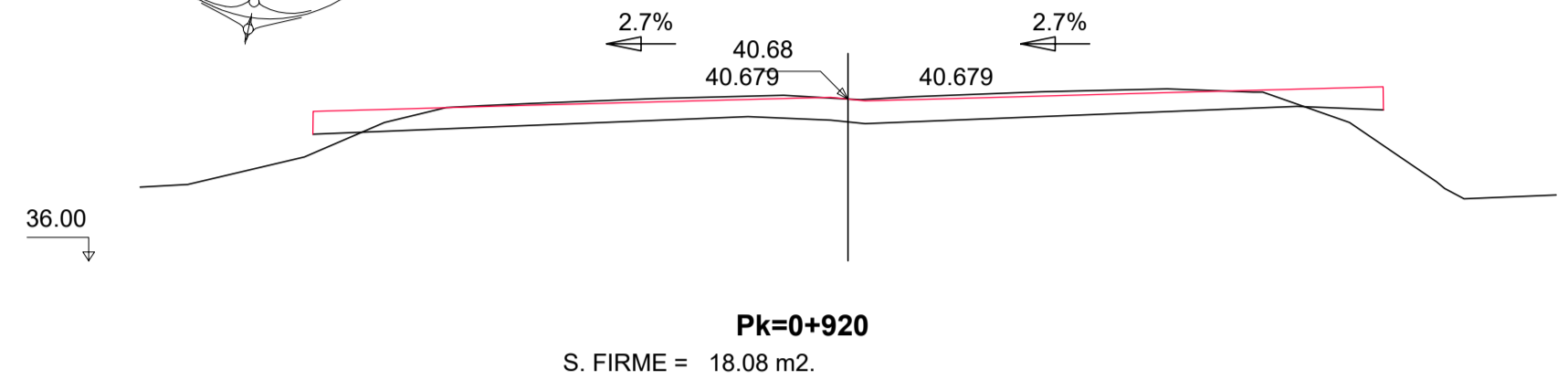
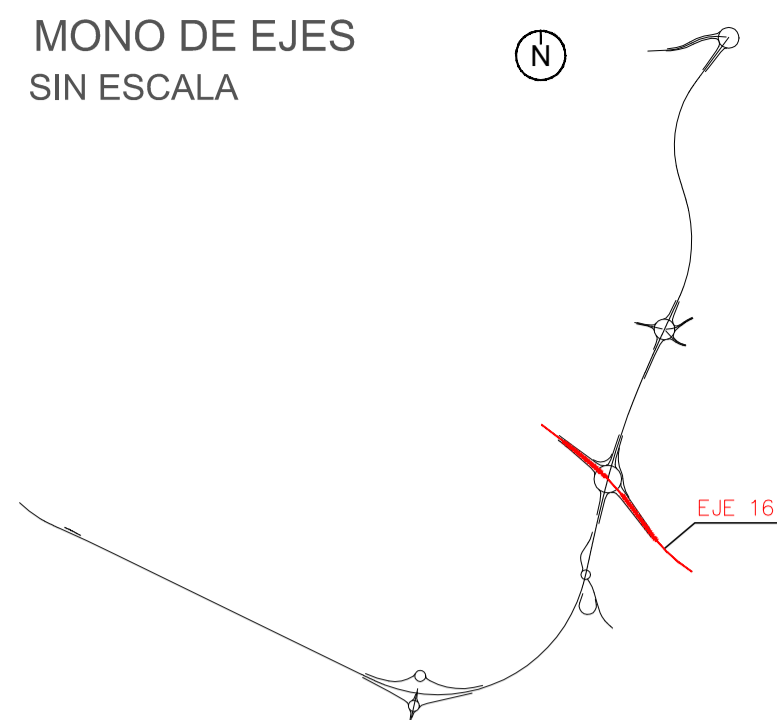

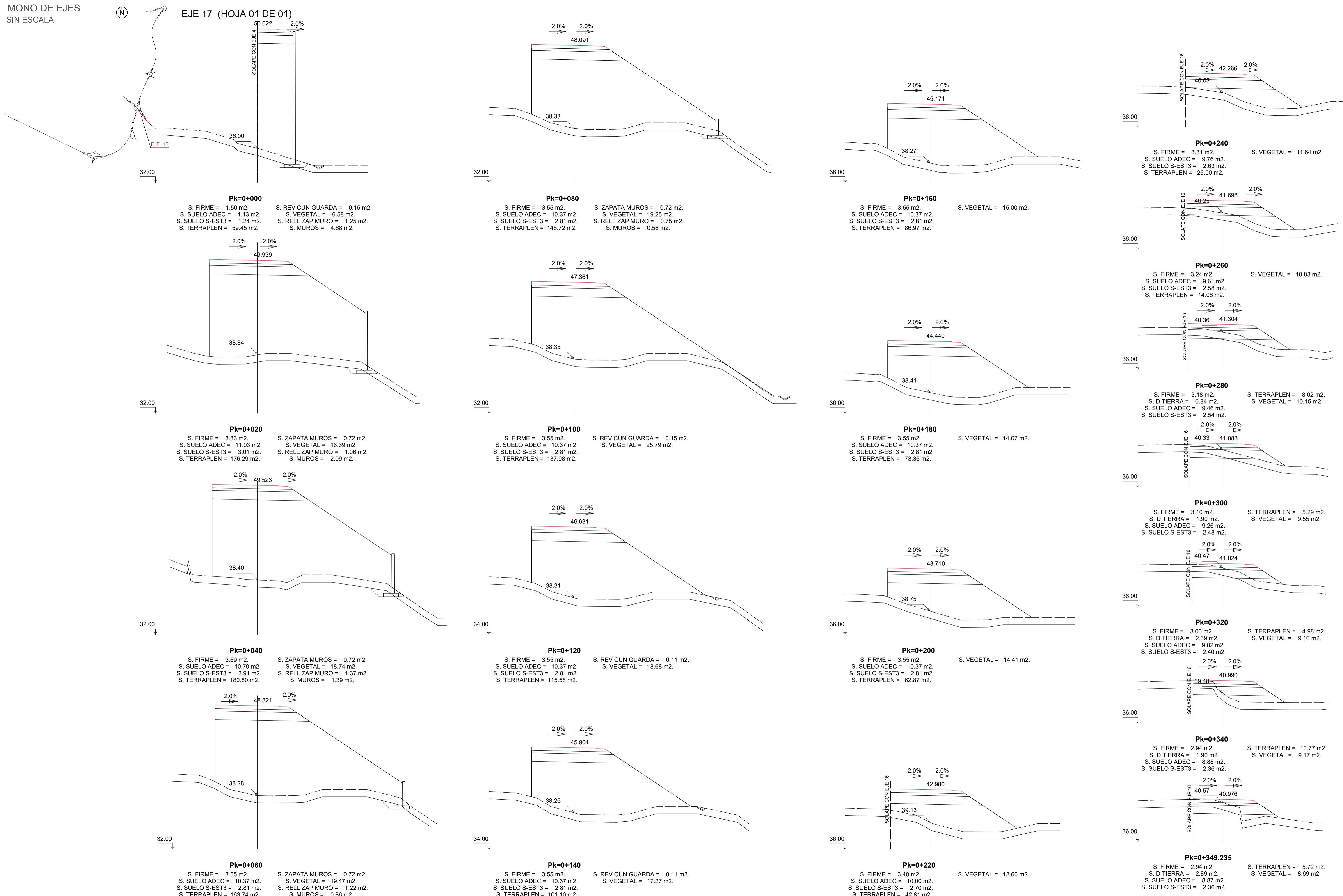

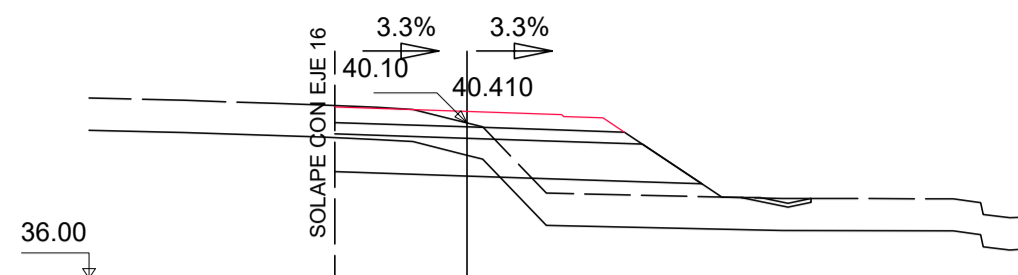
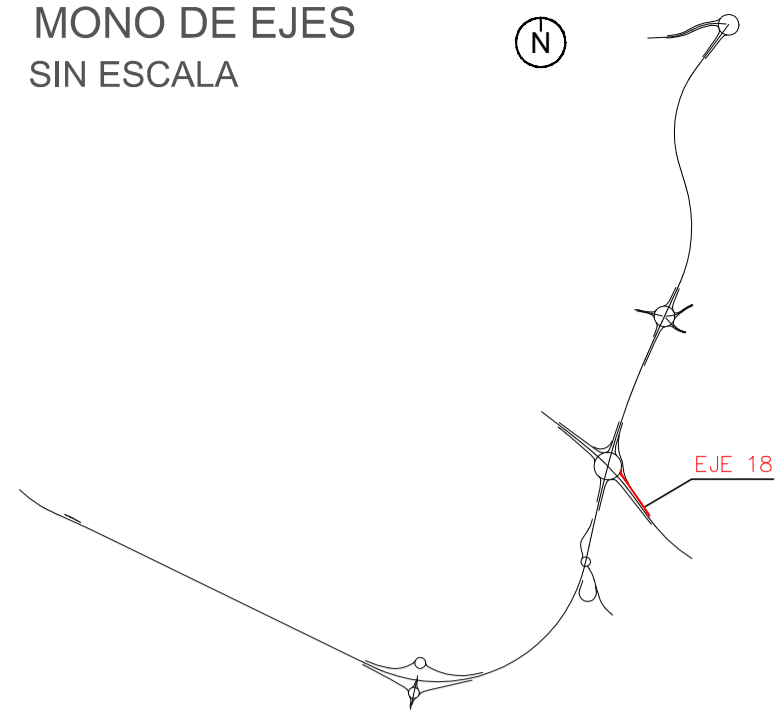

Pk=0+000
 S. FIRME = 2.96 m². S. TERRAPLEN = 8.04 m².
 S. D TIERRA = 3.16 m². S. REV CUN GUARDA = 0.16 m².
 S. SUELO ADEC = 8.93 m². S. VEGETAL = 10.71 m².
 S. SUELO S-EST3 = 2.37 m².

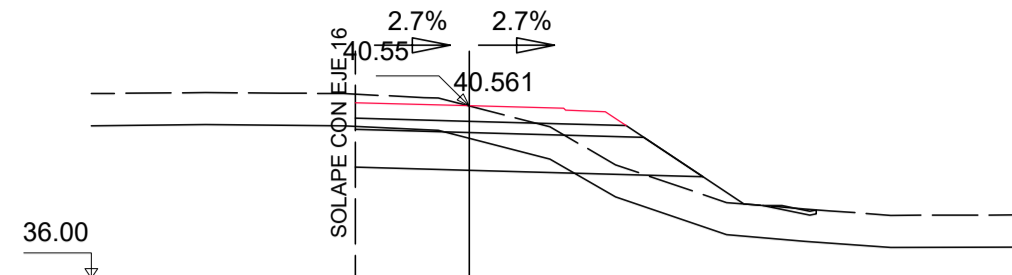

Pk=0+100
 S. FIRME = 2.75 m². S. TERRAPLEN = 5.27 m².
 S. D TIERRA = 4.50 m². S. REV CUN GUARDA = 0.12 m².
 S. SUELO ADEC = 8.41 m². S. VEGETAL = 10.36 m².
 S. SUELO S-EST3 = 2.22 m².

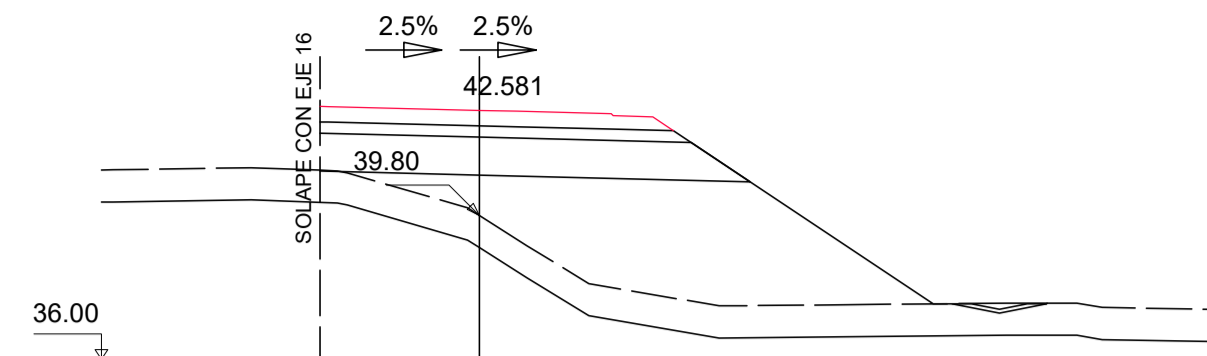

Pk=0+200
 S. FIRME = 3.64 m². S. REV CUN GUARDA = 0.20 m².
 S. SUELO ADEC = 10.59 m². S. VEGETAL = 16.34 m².
 S. SUELO S-EST3 = 2.87 m². S. TERRAPLEN = 44.51 m².

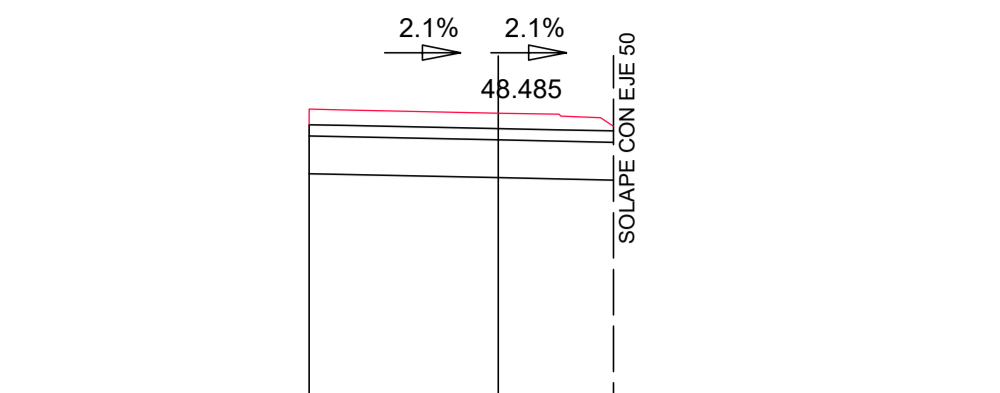

Pk=0+300
 S. FIRME = 3.18 m². S. VEGETAL = 6.84 m².
 S. SUELO ADEC = 9.05 m².
 S. SUELO S-EST3 = 2.42 m².
 S. TERRAPLEN = 72.32 m².

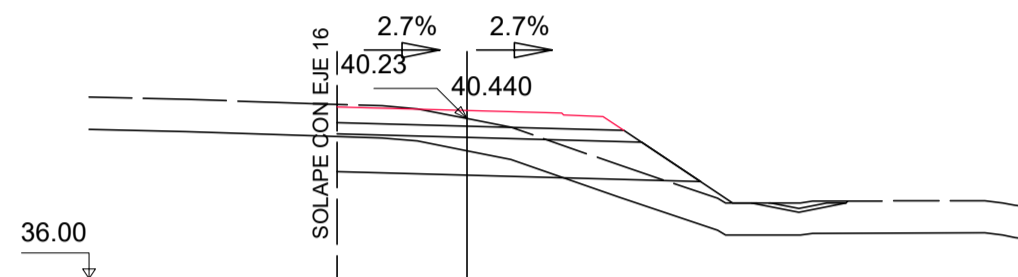

Pk=0+020
 S. FIRME = 2.92 m². S. TERRAPLEN = 5.16 m².
 S. D TIERRA = 3.89 m². S. REV CUN GUARDA = 0.20 m².
 S. SUELO ADEC = 8.84 m². S. VEGETAL = 11.48 m².
 S. SUELO S-EST3 = 2.35 m².

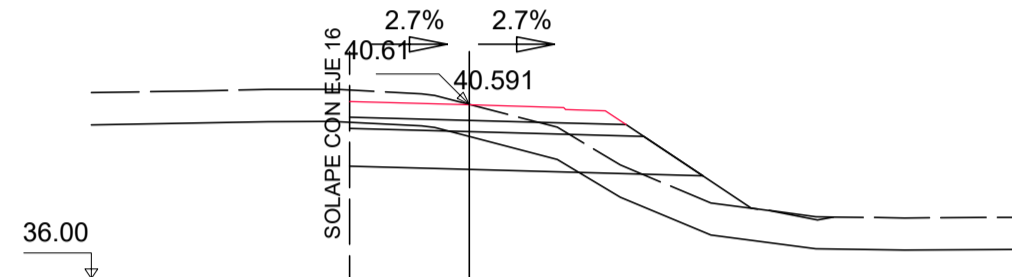

Pk=0+120
 S. FIRME = 2.81 m². S. TERRAPLEN = 5.92 m².
 S. D TIERRA = 4.96 m². S. VEGETAL = 10.88 m².
 S. SUELO ADEC = 8.57 m².
 S. SUELO S-EST3 = 2.26 m².

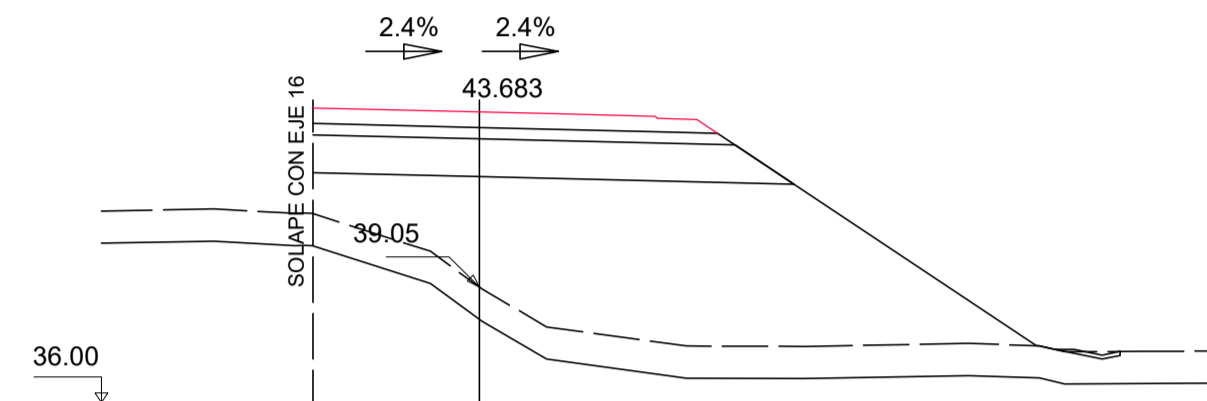

Pk=0+220
 S. FIRME = 4.20 m². S. REV CUN GUARDA = 0.15 m².
 S. SUELO ADEC = 11.95 m². S. VEGETAL = 18.15 m².
 S. SUELO S-EST3 = 3.28 m². S. TERRAPLEN = 73.22 m².

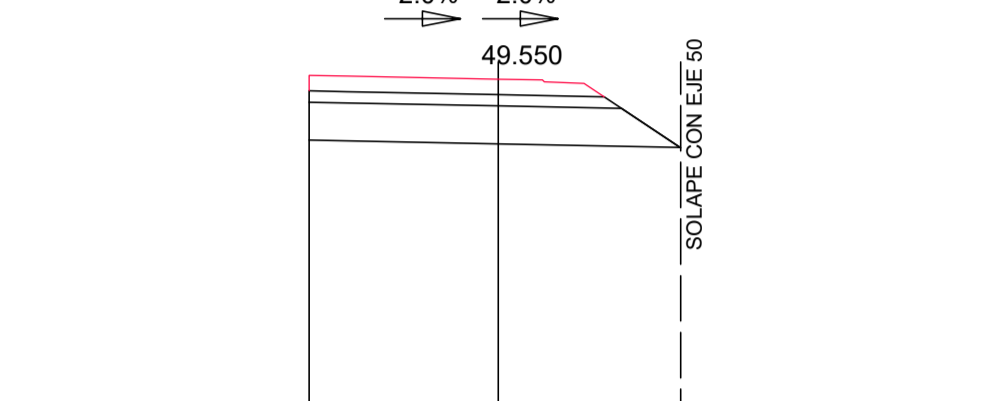

Pk=0+320
 S. FIRME = 3.01 m². S. VEGETAL = 8.35 m².
 S. SUELO ADEC = 9.04 m².
 S. SUELO S-EST3 = 2.41 m².
 S. TERRAPLEN = 99.74 m².

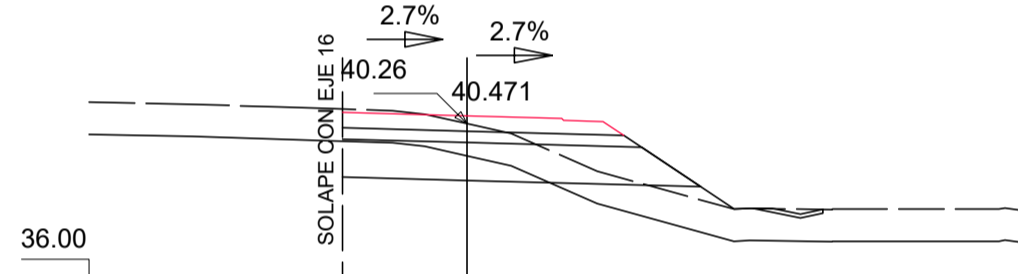

Pk=0+040
 S. FIRME = 2.86 m². S. TERRAPLEN = 5.33 m².
 S. D TIERRA = 3.71 m². S. REV CUN GUARDA = 0.16 m².
 S. SUELO ADEC = 8.69 m². S. VEGETAL = 10.80 m².
 S. SUELO S-EST3 = 2.30 m².

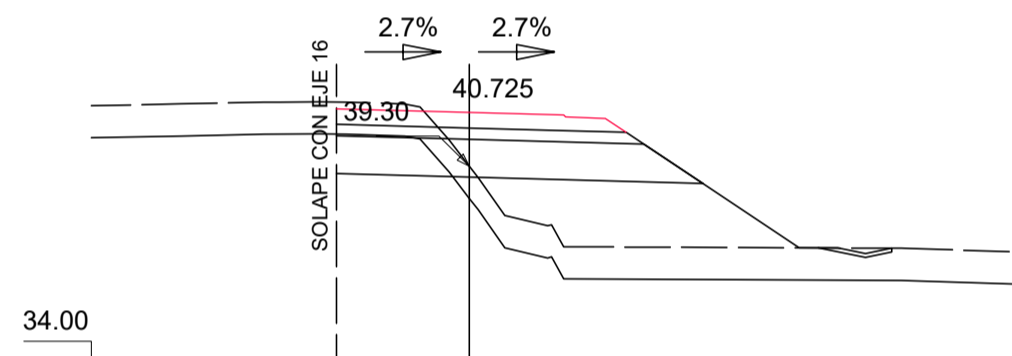

Pk=0+140
 S. FIRME = 2.95 m². S. TERRAPLEN = 20.06 m².
 S. D TIERRA = 2.71 m². S. REV CUN GUARDA = 0.17 m².
 S. SUELO ADEC = 8.91 m². S. VEGETAL = 12.49 m².
 S. SUELO S-EST3 = 2.37 m².

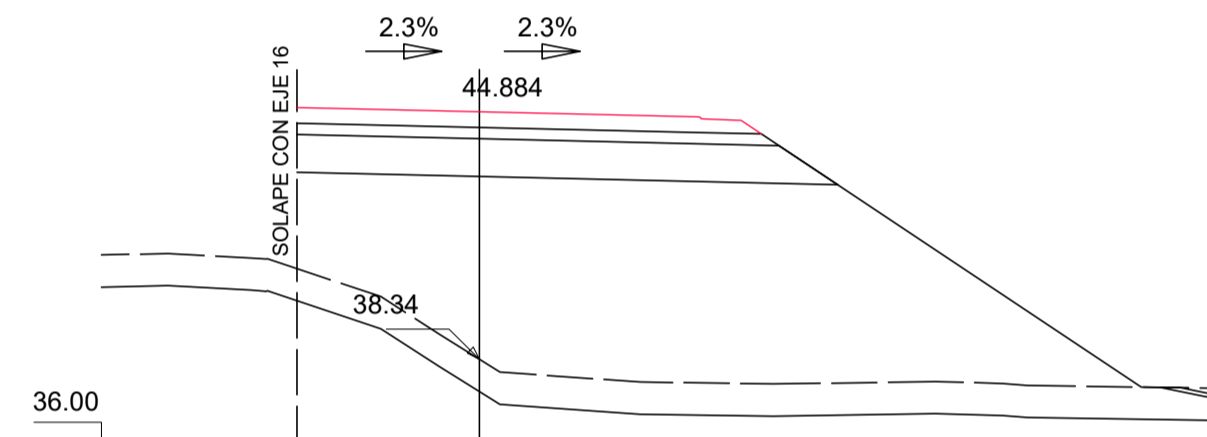

Pk=0+240
 S. FIRME = 4.85 m². S. REV CUN GUARDA = 0.16 m².
 S. SUELO ADEC = 13.53 m². S. VEGETAL = 20.98 m².
 S. SUELO S-EST3 = 3.76 m². S. TERRAPLEN = 108.41 m².

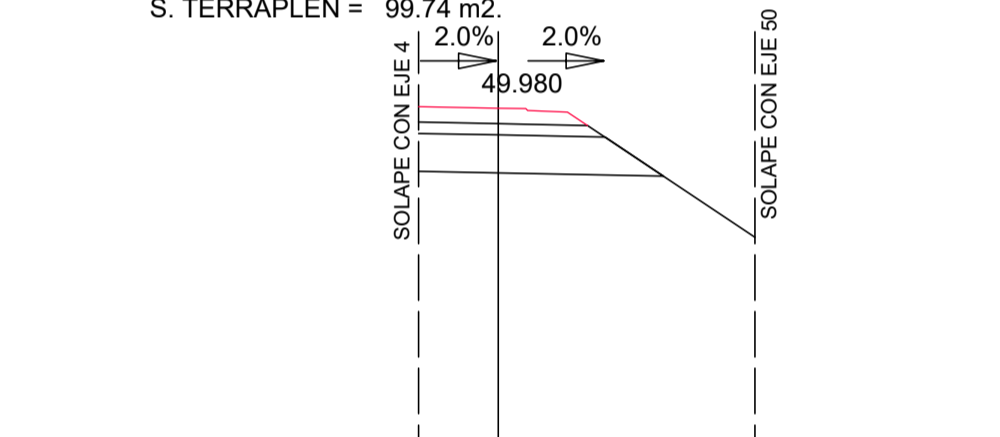

Pk=0+340
 S. FIRME = 1.64 m². S. VEGETAL = 7.56 m².
 S. SUELO ADEC = 5.70 m².
 S. SUELO S-EST3 = 1.41 m².
 S. TERRAPLEN = 94.53 m².

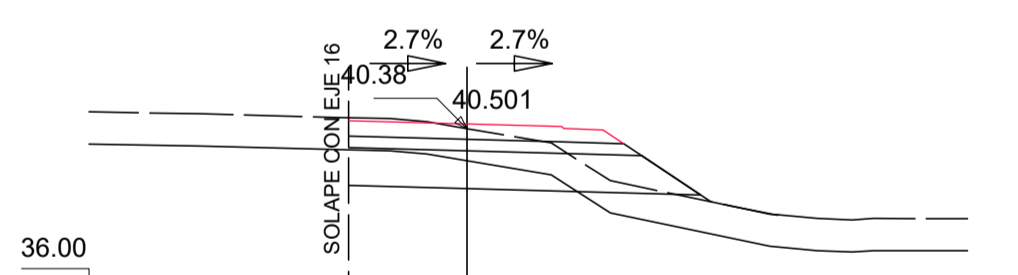

Pk=0+060
 S. FIRME = 2.80 m². S. TERRAPLEN = 3.82 m².
 S. D TIERRA = 4.21 m². S. REV CUN GUARDA = 0.14 m².
 S. SUELO ADEC = 8.53 m². S. VEGETAL = 9.67 m².
 S. SUELO S-EST3 = 2.25 m².

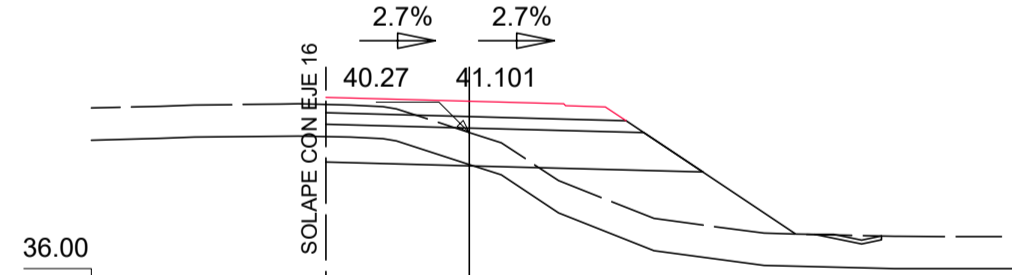

Pk=0+160
 S. FIRME = 3.07 m². S. TERRAPLEN = 13.69 m².
 S. D TIERRA = 1.85 m². S. REV CUN GUARDA = 0.15 m².
 S. SUELO ADEC = 9.19 m². S. VEGETAL = 12.49 m².
 S. SUELO S-EST3 = 2.45 m².

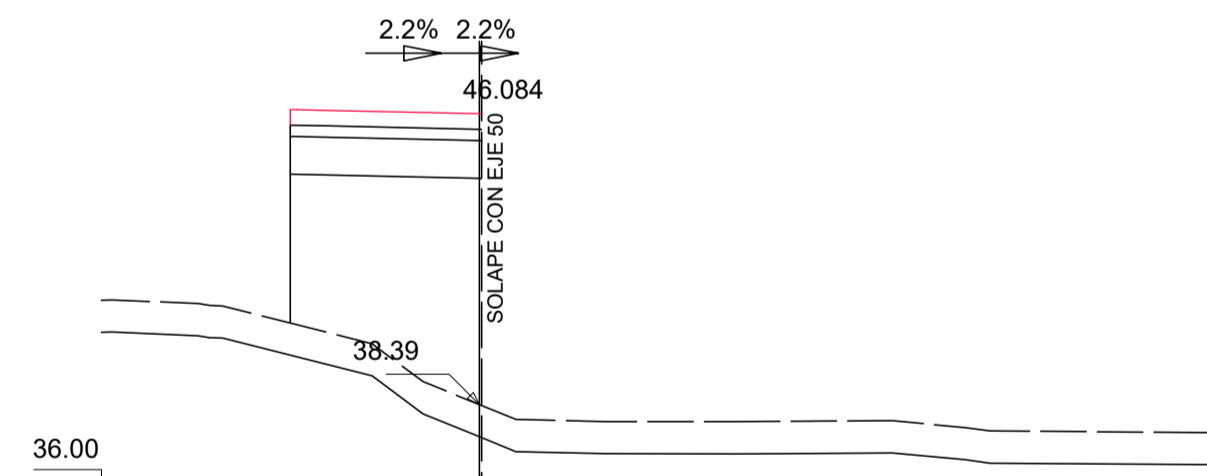

Pk=0+260
 S. FIRME = 2.08 m². S. VEGETAL = 4.30 m².
 S. SUELO ADEC = 5.06 m².
 S. SUELO S-EST3 = 1.52 m². S. TERRAPLEN = 28.85 m².

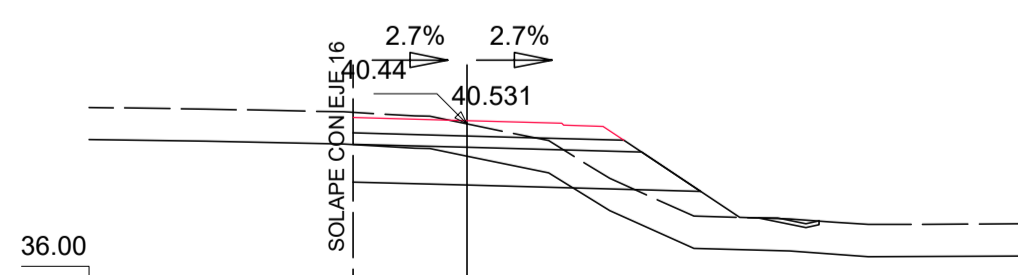

Pk=0+080
 S. FIRME = 2.75 m². S. TERRAPLEN = 5.67 m².
 S. D TIERRA = 4.17 m². S. REV CUN GUARDA = 0.14 m².
 S. SUELO ADEC = 8.41 m². S. VEGETAL = 10.48 m².
 S. SUELO S-EST3 = 2.22 m².

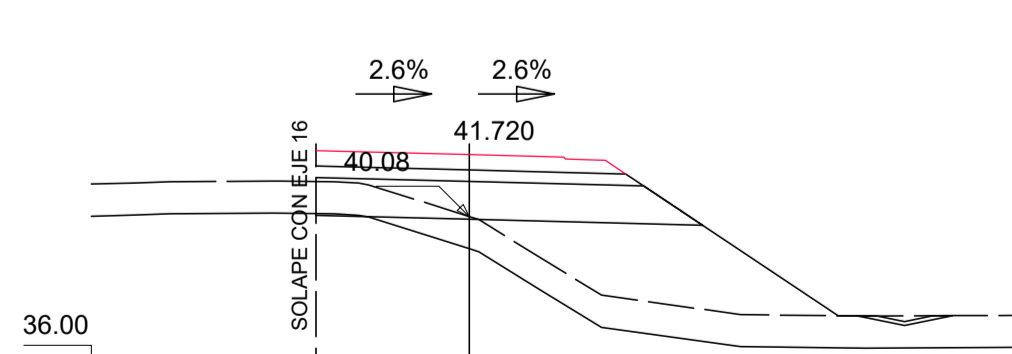

Pk=0+180
 S. FIRME = 3.17 m². S. TERRAPLEN = 24.40 m².
 S. D TIERRA = 0.05 m². S. REV CUN GUARDA = 0.20 m².
 S. SUELO ADEC = 9.44 m². S. VEGETAL = 14.30 m².
 S. SUELO S-EST3 = 2.53 m².

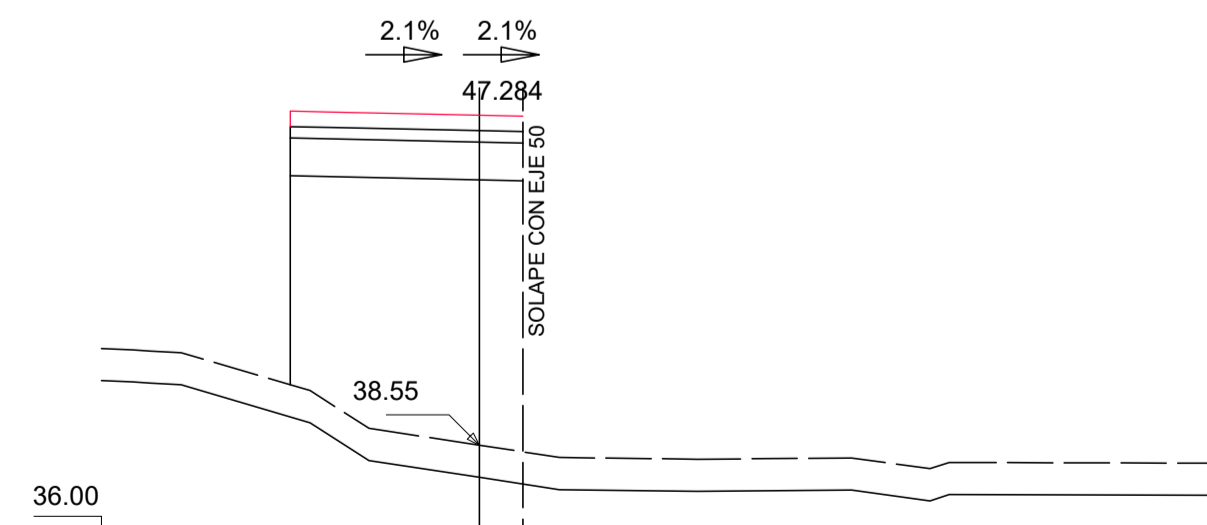

Pk=0+280
 S. FIRME = 2.52 m². S. VEGETAL = 5.23 m².
 S. SUELO ADEC = 6.16 m².
 S. SUELO S-EST3 = 1.85 m². S. TERRAPLEN = 45.88 m².

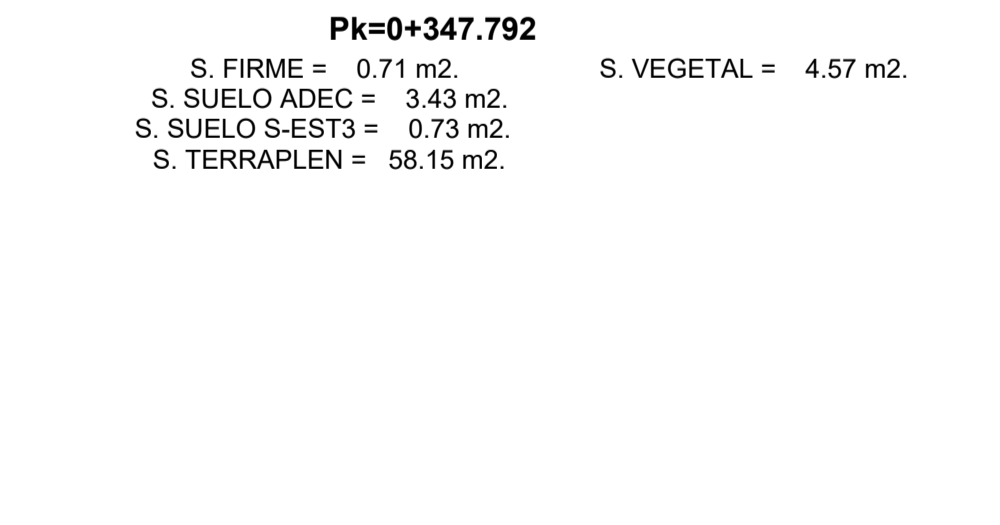

Pk=0+347.792
 S. FIRME = 0.71 m². S. VEGETAL = 4.57 m².
 S. SUELO ADEC = 3.43 m².
 S. SUELO S-EST3 = 0.73 m². S. TERRAPLEN = 58.15 m².

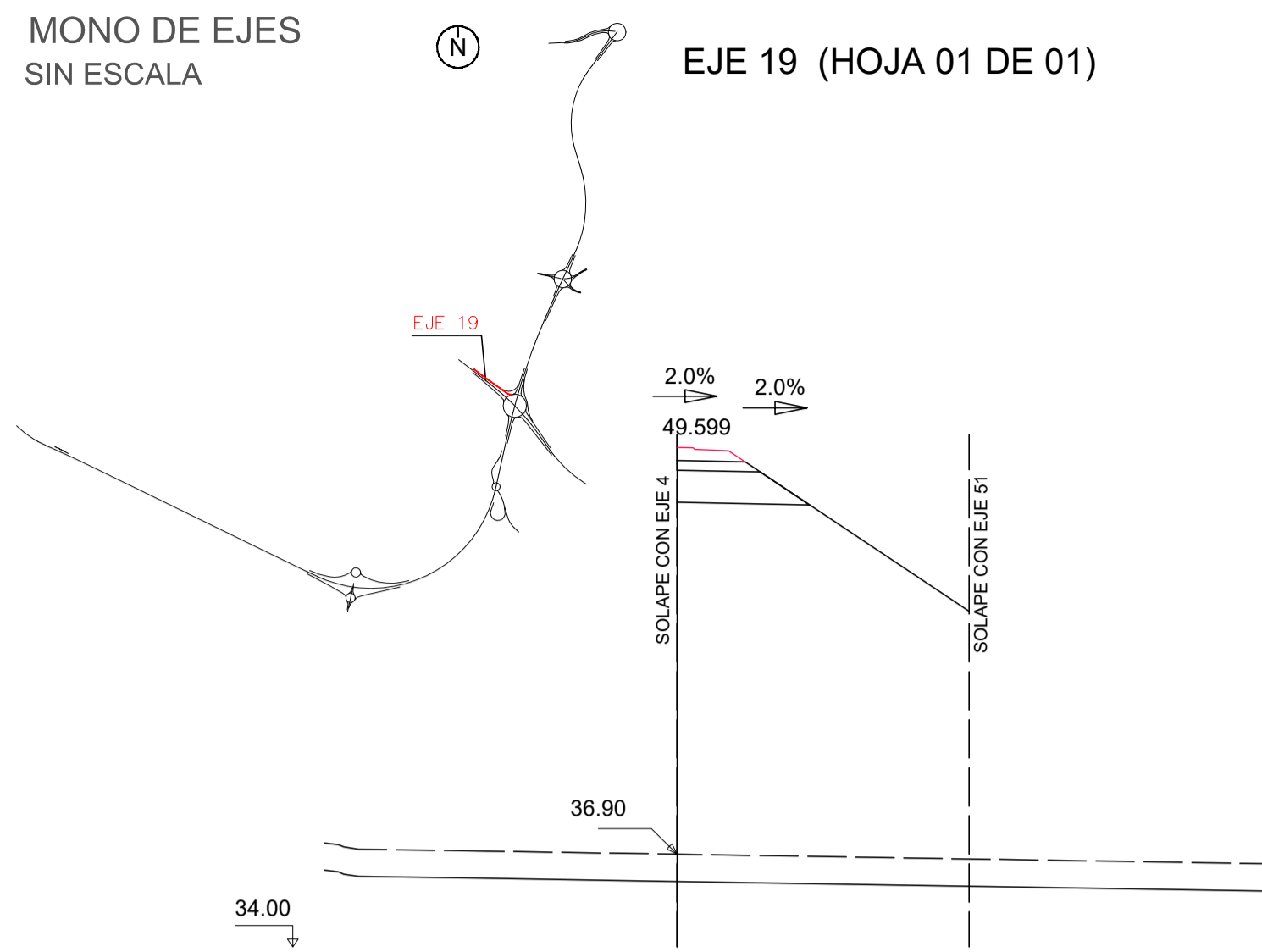

Pk=0+000
 S. FIRME = 0.68 m2.
 S. SUELO ADEC = 3.37 m2.
 S. SUELO S-EST3 = 0.71 m2.
 S. TERRAPLEN = 99.87 m2.
 S. VEGETAL = 7.76 m2.

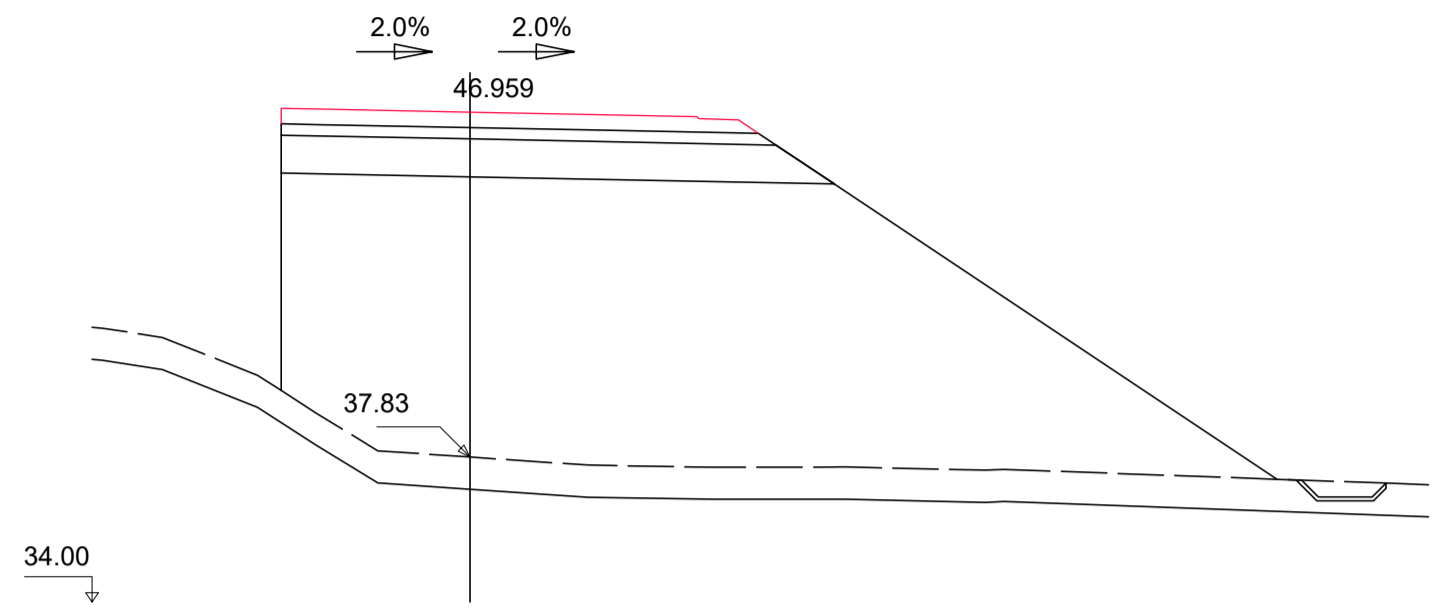

Pk=0+080
 S. FIRME = 4.99 m2.
 S. SUELO ADEC = 13.87 m2.
 S. SUELO S-EST3 = 3.86 m2.
 S. TERRAPLEN = 174.56 m2.
 S. REV CUN GUARDA = 0.27 m2.
 S. VEGETAL = 24.84 m2.

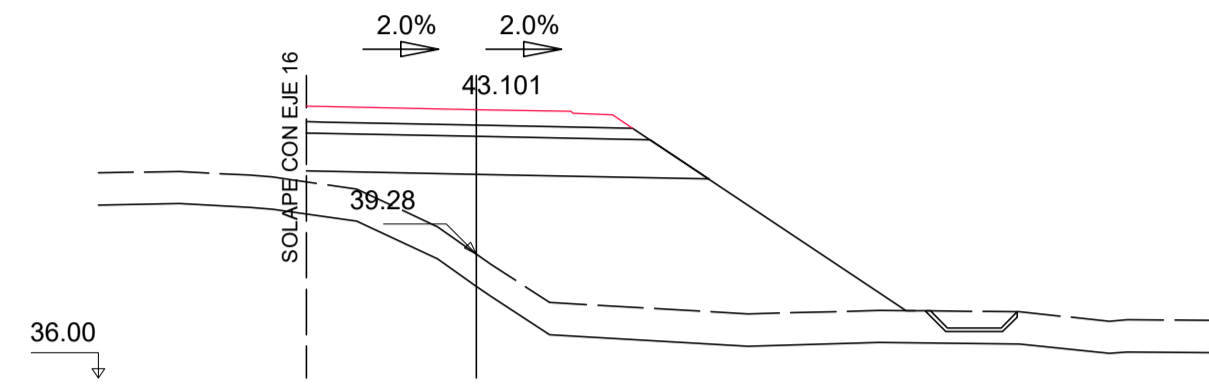

Pk=0+160
 S. FIRME = 3.35 m2.
 S. SUELO ADEC = 9.86 m2.
 S. SUELO S-EST3 = 2.66 m2.
 S. TERRAPLEN = 48.25 m2.
 S. REV CUN GUARDA = 0.27 m2.
 S. VEGETAL = 15.98 m2.

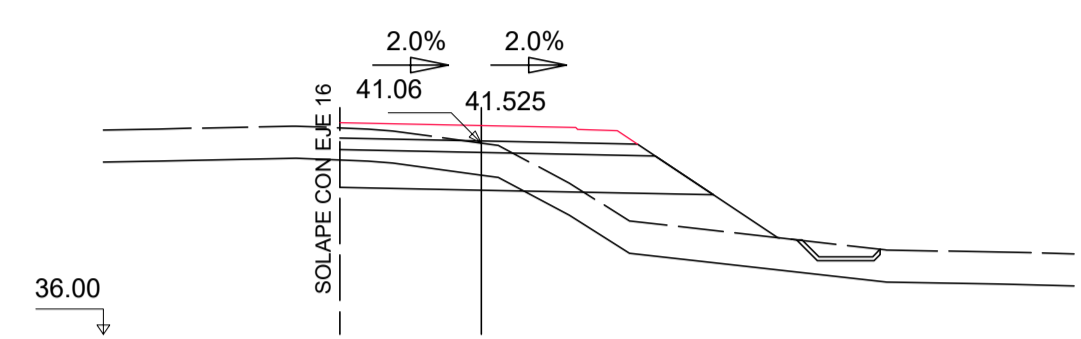

Pk=0+240
 S. FIRME = 3.04 m2.
 S. D TIERRA = 2.51 m2.
 S. SUELO ADEC = 9.11 m2.
 S. SUELO S-EST3 = 2.43 m2.
 S. TERRAPLEN = 9.66 m2.
 S. REV CUN GUARDA = 0.24 m2.
 S. VEGETAL = 12.15 m2.



Pk=0+020
 S. FIRME = 3.28 m2.
 S. SUELO ADEC = 9.70 m2.
 S. SUELO S-EST3 = 2.61 m2.
 S. TERRAPLEN = 157.42 m2.
 S. VEGETAL = 12.09 m2.

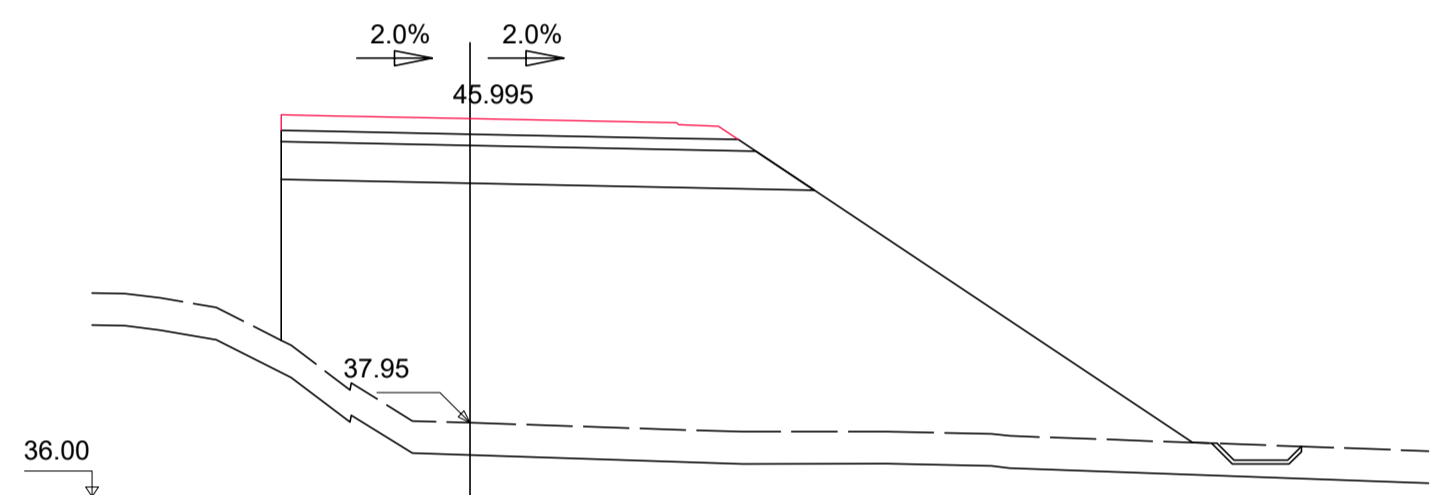

Pk=0+100
 S. FIRME = 4.77 m2.
 S. SUELO ADEC = 13.33 m2.
 S. SUELO S-EST3 = 3.70 m2.
 S. TERRAPLEN = 139.82 m2.
 S. REV CUN GUARDA = 0.27 m2.
 S. VEGETAL = 22.94 m2.

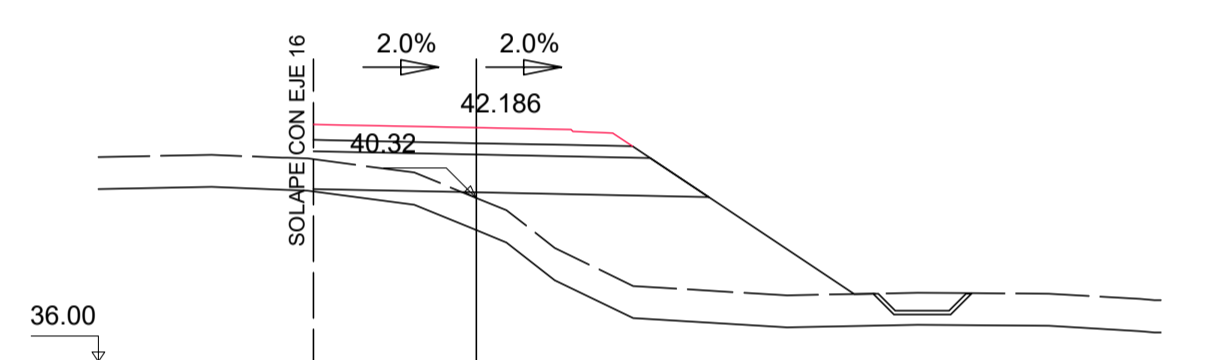

Pk=0+180
 S. FIRME = 3.27 m2.
 S. SUELO ADEC = 9.68 m2.
 S. SUELO S-EST3 = 2.60 m2.
 S. TERRAPLEN = 26.84 m2.
 S. REV CUN GUARDA = 0.29 m2.
 S. VEGETAL = 14.80 m2.

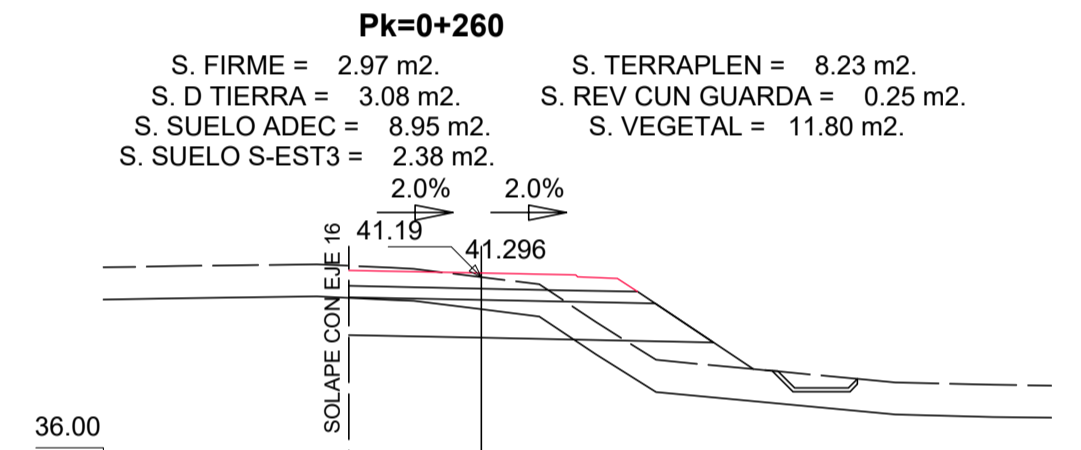

Pk=0+260
 S. FIRME = 2.97 m2.
 S. D TIERRA = 3.08 m2.
 S. SUELO ADEC = 8.95 m2.
 S. SUELO S-EST3 = 2.38 m2.
 S. TERRAPLEN = 8.23 m2.
 S. REV CUN GUARDA = 0.25 m2.
 S. VEGETAL = 11.80 m2.

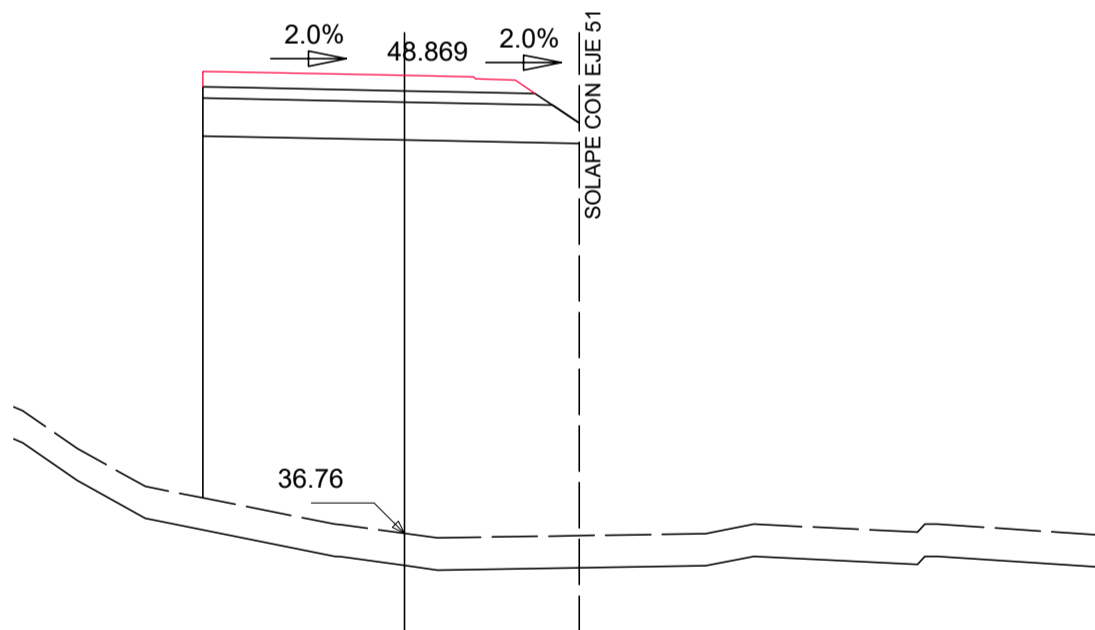

Pk=0+040
 S. FIRME = 3.42 m2.
 S. SUELO ADEC = 9.80 m2.
 S. SUELO S-EST3 = 2.71 m2.
 S. TERRAPLEN = 110.24 m2.
 S. VEGETAL = 8.47 m2.

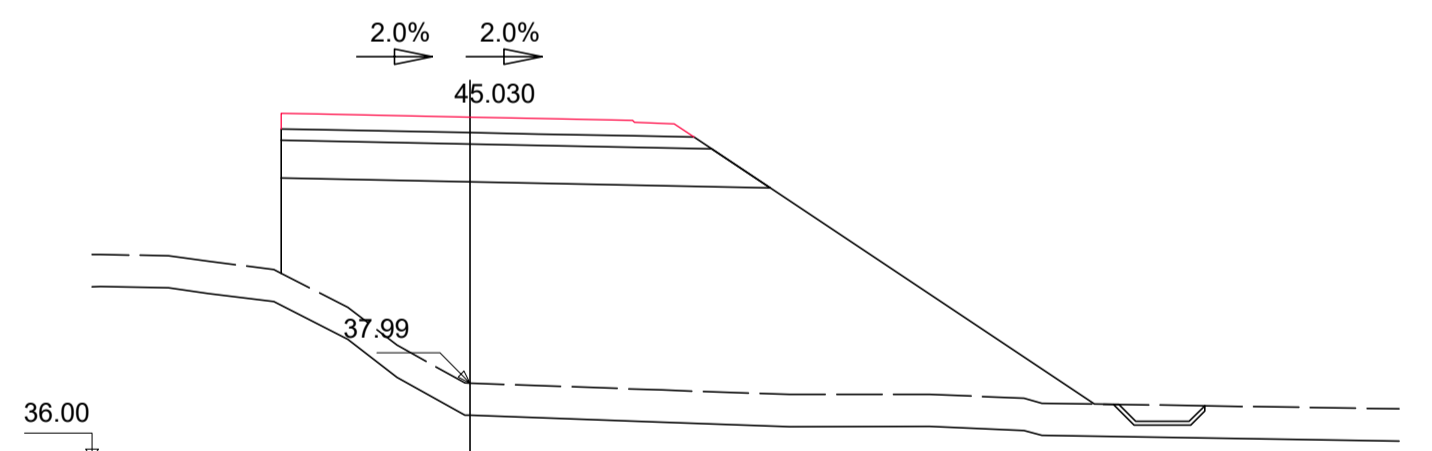

Pk=0+120
 S. FIRME = 4.29 m2.
 S. SUELO ADEC = 12.16 m2.
 S. SUELO S-EST3 = 3.35 m2.
 S. TERRAPLEN = 105.03 m2.
 S. REV CUN GUARDA = 0.27 m2.
 S. VEGETAL = 20.77 m2.

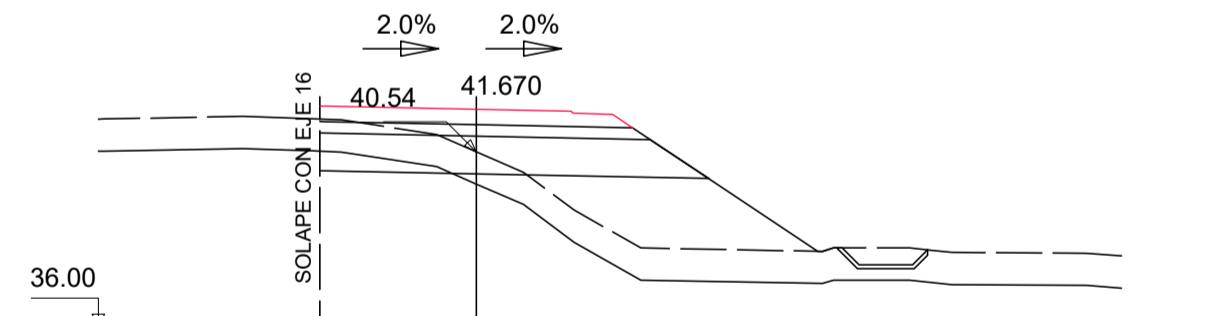

Pk=0+200
 S. FIRME = 3.20 m2.
 S. D TIERRA = 1.17 m2.
 S. SUELO ADEC = 9.51 m2.
 S. SUELO S-EST3 = 2.55 m2.
 S. TERRAPLEN = 17.81 m2.
 S. REV CUN GUARDA = 0.27 m2.
 S. VEGETAL = 13.67 m2.

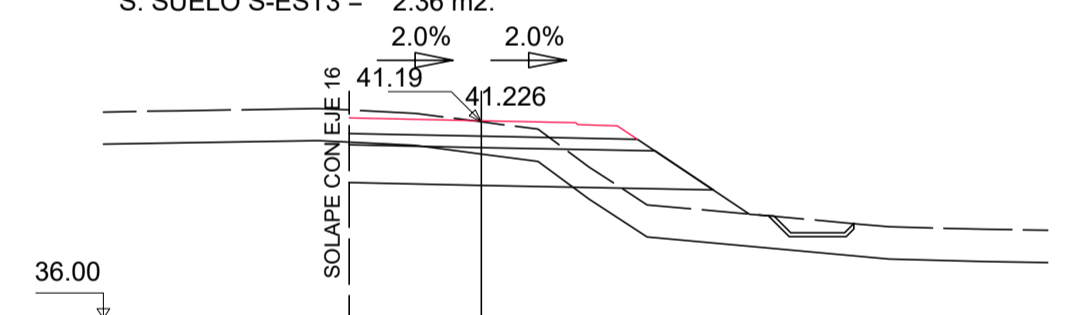

Pk=0+280
 S. FIRME = 2.94 m2.
 S. D TIERRA = 4.47 m2.
 S. SUELO ADEC = 8.87 m2.
 S. SUELO S-EST3 = 2.36 m2.
 S. TERRAPLEN = 6.33 m2.
 S. REV CUN GUARDA = 0.25 m2.
 S. VEGETAL = 11.43 m2.

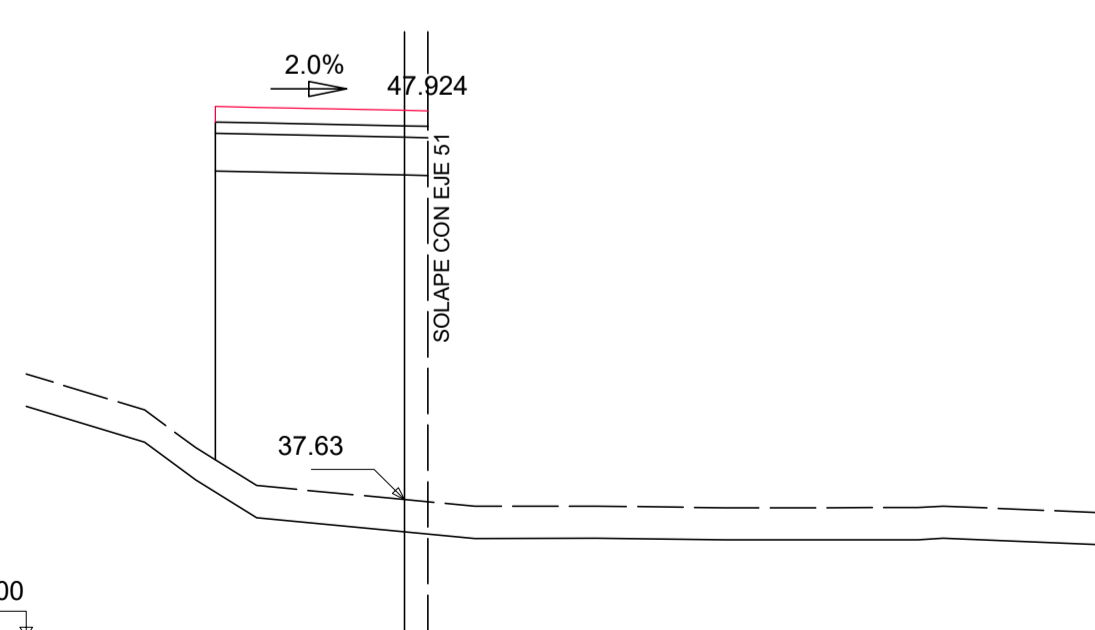

Pk=0+060
 S. FIRME = 2.31 m2.
 S. SUELO ADEC = 5.63 m2.
 S. SUELO S-EST3 = 1.69 m2.
 S. TERRAPLEN = 51.85 m2.
 S. VEGETAL = 4.78 m2.

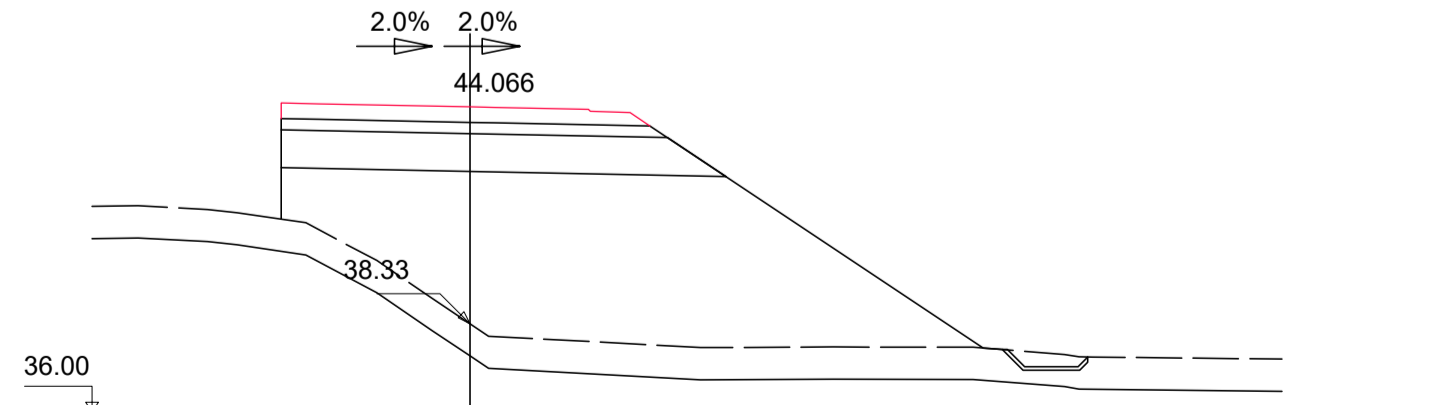

Pk=0+140
 S. FIRME = 3.81 m2.
 S. SUELO ADEC = 11.00 m2.
 S. SUELO S-EST3 = 3.00 m2.
 S. TERRAPLEN = 75.03 m2.
 S. REV CUN GUARDA = 0.25 m2.
 S. VEGETAL = 18.14 m2.

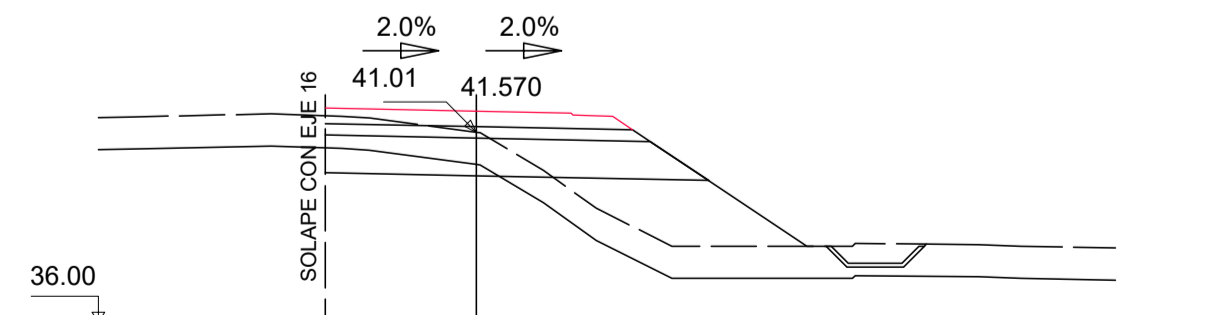

Pk=0+220
 S. FIRME = 3.14 m2.
 S. D TIERRA = 2.17 m2.
 S. SUELO ADEC = 9.37 m2.
 S. SUELO S-EST3 = 2.51 m2.
 S. TERRAPLEN = 14.70 m2.
 S. REV CUN GUARDA = 0.29 m2.
 S. VEGETAL = 13.51 m2.

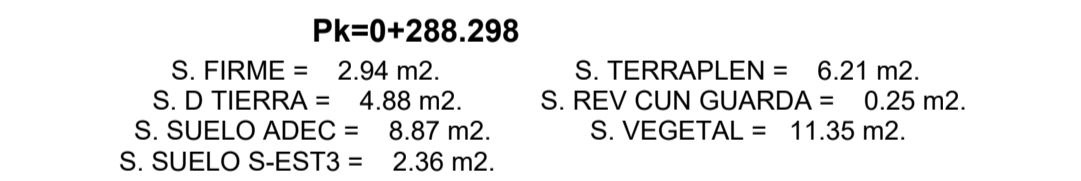

Pk=0+288.298
 S. FIRME = 2.94 m2.
 S. D TIERRA = 4.88 m2.
 S. SUELO ADEC = 8.87 m2.
 S. SUELO S-EST3 = 2.36 m2.
 S. TERRAPLEN = 6.21 m2.
 S. REV CUN GUARDA = 0.25 m2.
 S. VEGETAL = 11.35 m2.

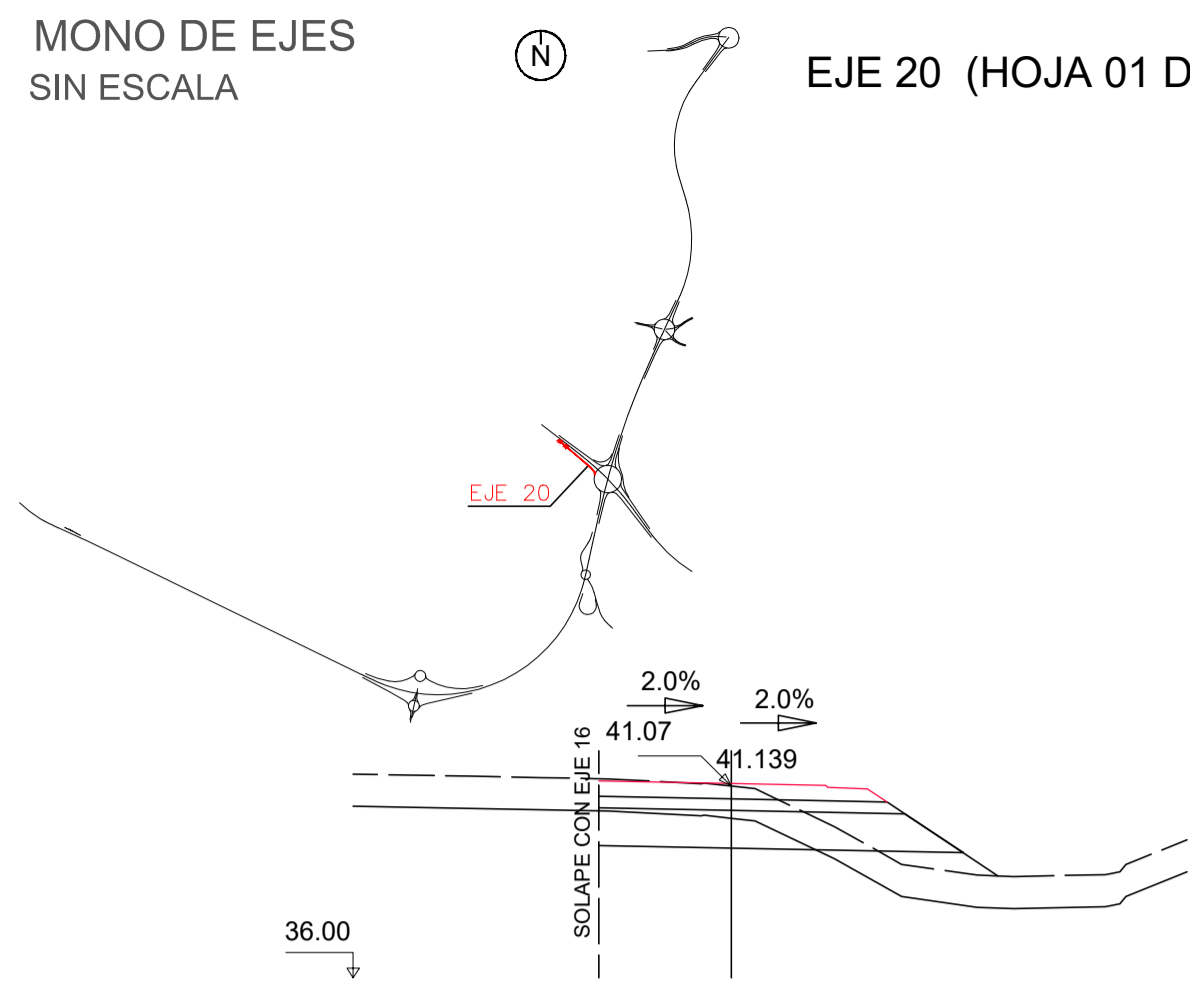

Pk=0+000
 S. FIRME = 2.94 m2.
 S. D TIERRA = 4.11 m2.
 S. SUELO ADEC = 8.87 m2.
 S. SUELO S-EST3 = 2.36 m2.
 S. TERRAPLEN = 4.46 m2.
 S. VEGETAL = 8.97 m2.

Pk=0+020
 S. FIRME = 2.95 m2.
 S. D TIERRA = 4.25 m2.
 S. SUELO ADEC = 8.90 m2.
 S. SUELO S-EST3 = 2.37 m2.
 S. TERRAPLEN = 4.61 m2.
 S. VEGETAL = 9.05 m2.

Pk=0+040
 S. FIRME = 3.03 m2.
 S. D TIERRA = 4.31 m2.
 S. SUELO ADEC = 9.10 m2.
 S. SUELO S-EST3 = 2.43 m2.
 S. TERRAPLEN = 4.46 m2.
 S. VEGETAL = 9.21 m2.

Pk=0+060
 S. FIRME = 3.16 m2.
 S. D TIERRA = 3.94 m2.
 S. SUELO ADEC = 9.42 m2.
 S. SUELO S-EST3 = 2.52 m2.
 S. TERRAPLEN = 5.50 m2.
 S. VEGETAL = 9.47 m2.

Pk=0+080
 S. FIRME = 3.24 m2.
 S. D TIERRA = 1.46 m2.
 S. SUELO ADEC = 9.61 m2.
 S. SUELO S-EST3 = 2.58 m2.
 S. TERRAPLEN = 9.95 m2.
 S. VEGETAL = 10.07 m2.

Pk=0+100
 S. FIRME = 3.32 m2.
 S. SUELO ADEC = 9.79 m2.
 S. SUELO S-EST3 = 2.64 m2.
 S. TERRAPLEN = 21.49 m2.
 S. VEGETAL = 10.89 m2.

Pk=0+120
 S. FIRME = 3.44 m2.
 S. SUELO ADEC = 10.09 m2.
 S. SUELO S-EST3 = 2.73 m2.
 S. TERRAPLEN = 38.69 m2.
 S. VEGETAL = 12.18 m2.

Pk=0+140
 S. FIRME = 3.55 m2.
 S. SUELO ADEC = 10.37 m2.
 S. SUELO S-EST3 = 2.81 m2.
 S. TERRAPLEN = 59.10 m2.
 S. VEGETAL = 13.65 m2.

Pk=0+160
 S. FIRME = 3.55 m2.
 S. SUELO ADEC = 10.37 m2.
 S. SUELO S-EST3 = 2.81 m2.
 S. TERRAPLEN = 79.21 m2.
 S. VEGETAL = 14.89 m2.

Pk=0+180
 S. FIRME = 3.55 m2.
 S. SUELO ADEC = 10.37 m2.
 S. SUELO S-EST3 = 2.81 m2.
 S. TERRAPLEN = 109.49 m2.
 S. VEGETAL = 17.36 m2.

Pk=0+200
 S. FIRME = 3.55 m2.
 S. SUELO ADEC = 10.37 m2.
 S. SUELO S-EST3 = 2.81 m2.
 S. TERRAPLEN = 124.99 m2.
 S. VEGETAL = 18.40 m2.

Pk=0+220
 S. FIRME = 3.55 m2.
 S. SUELO ADEC = 10.37 m2.
 S. SUELO S-EST3 = 2.81 m2.
 S. TERRAPLEN = 148.49 m2.
 S. VEGETAL = 19.94 m2.
 S. RELL ZAP MURO = 0.32 m2.
 S. MUROS = 0.26 m2.

Pk=0+240
 S. FIRME = 3.55 m2.
 S. SUELO ADEC = 10.37 m2.
 S. SUELO S-EST3 = 2.81 m2.
 S. TERRAPLEN = 182.80 m2.
 S. VEGETAL = 20.64 m2.
 S. RELL ZAP MURO = 0.22 m2.
 S. MUROS = 0.47 m2.

Pk=0+260
 S. FIRME = 3.55 m2.
 S. SUELO ADEC = 10.37 m2.
 S. SUELO S-EST3 = 2.81 m2.
 S. TERRAPLEN = 202.17 m2.
 S. VEGETAL = 18.76 m2.
 S. RELL ZAP MURO = 0.21 m2.
 S. MUROS = 1.27 m2.

Pk=0+277.277
 S. FIRME = 1.50 m2.
 S. SUELO ADEC = 5.37 m2.
 S. SUELO S-EST3 = 1.31 m2.
 S. TERRAPLEN = 118.56 m2.
 S. VEGETAL = 11.02 m2.
 S. RELL ZAP MURO = 0.37 m2.
 S. MUROS = 2.20 m2.

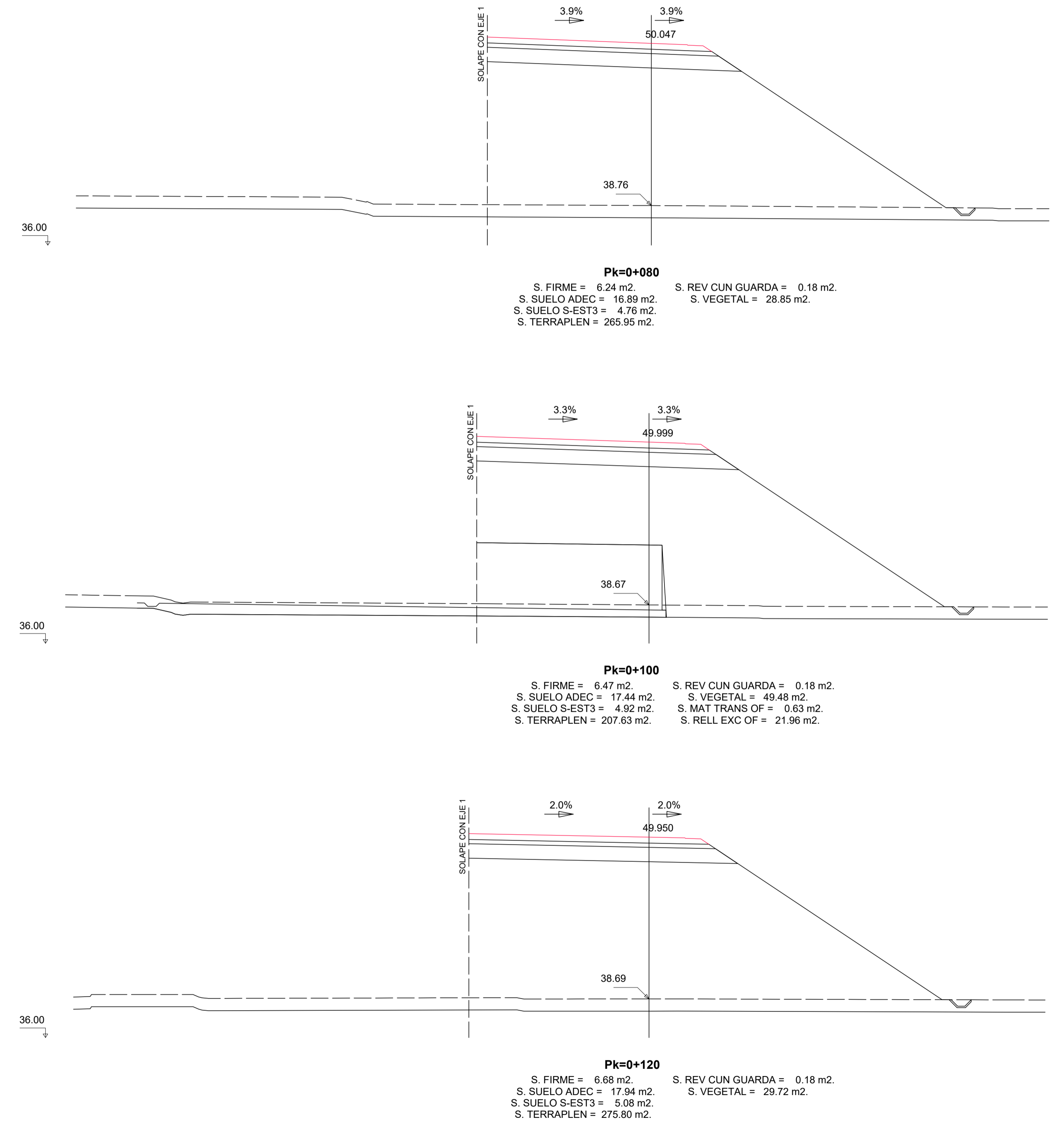
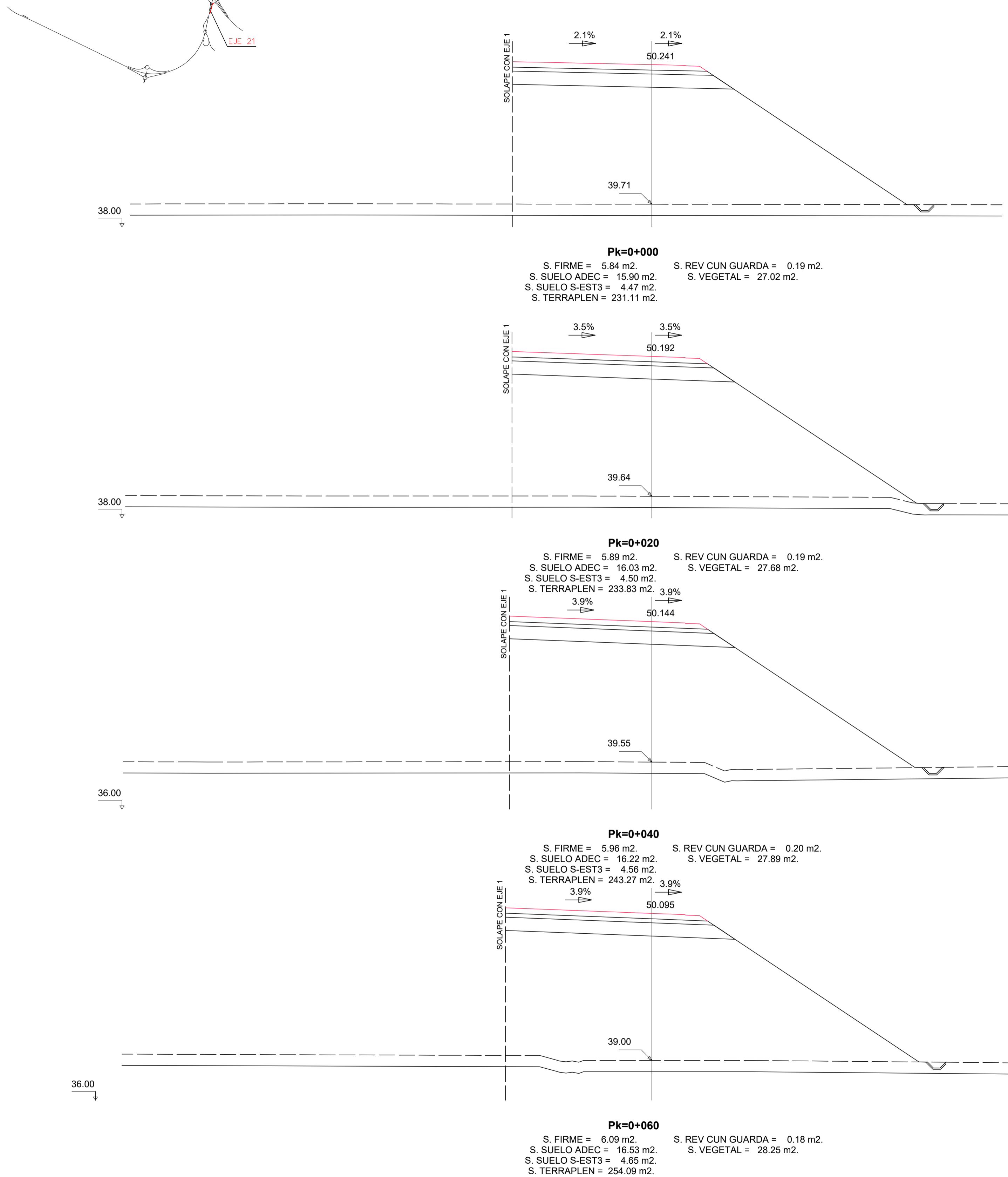

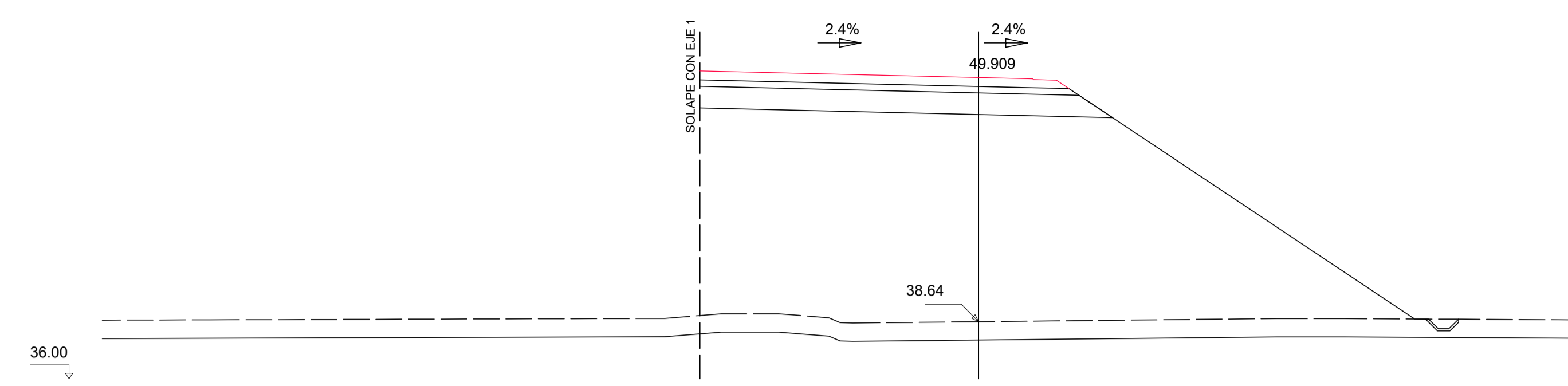

Pk=0+140
 S. FIRME = 6.81 m². S. REV CUN GUARDA = 0.18 m².
 S. SUELO ADEC = 18.28 m². S. VEGETAL = 29.77 m².
 S. SUELO S-EST3 = 5.18 m².
 S. TERRAPLEN = 275.80 m².

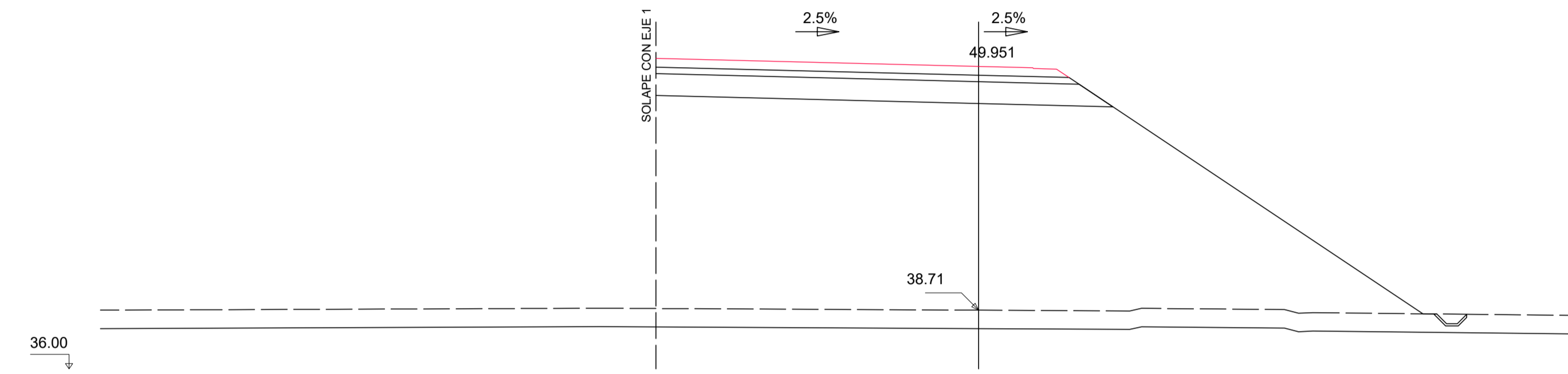

Pk=0+160
 S. FIRME = 7.65 m². S. REV CUN GUARDA = 0.18 m².
 S. SUELO ADEC = 20.32 m². S. VEGETAL = 31.83 m².
 S. SUELO S-EST3 = 5.79 m².
 S. TERRAPLEN = 300.61 m².

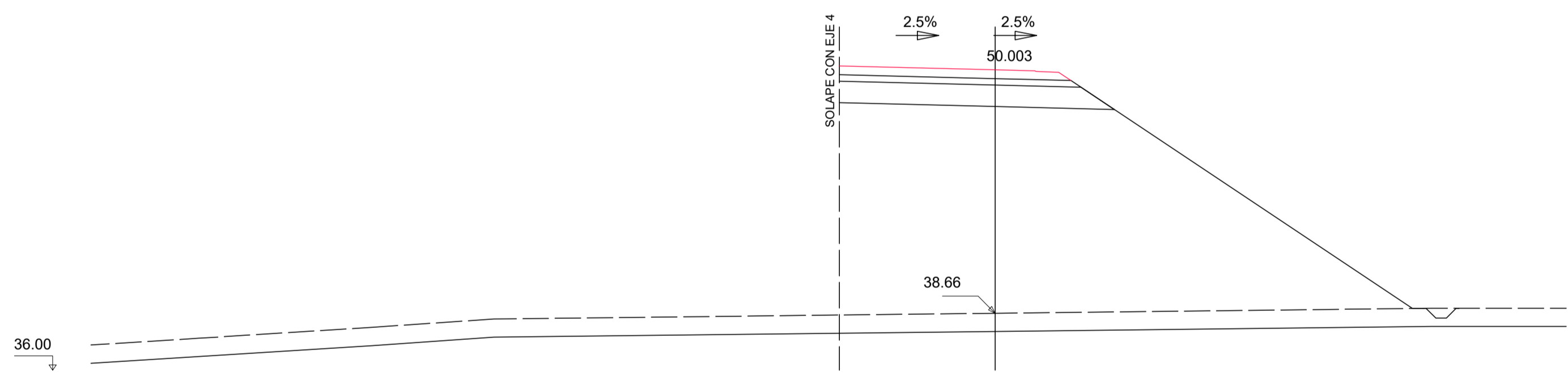

Pk=0+180
 S. FIRME = 4.26 m². S. VEGETAL = 23.18 m².
 S. SUELO ADEC = 12.05 m².
 S. SUELO S-EST3 = 3.31 m².
 S. TERRAPLEN = 212.87 m².

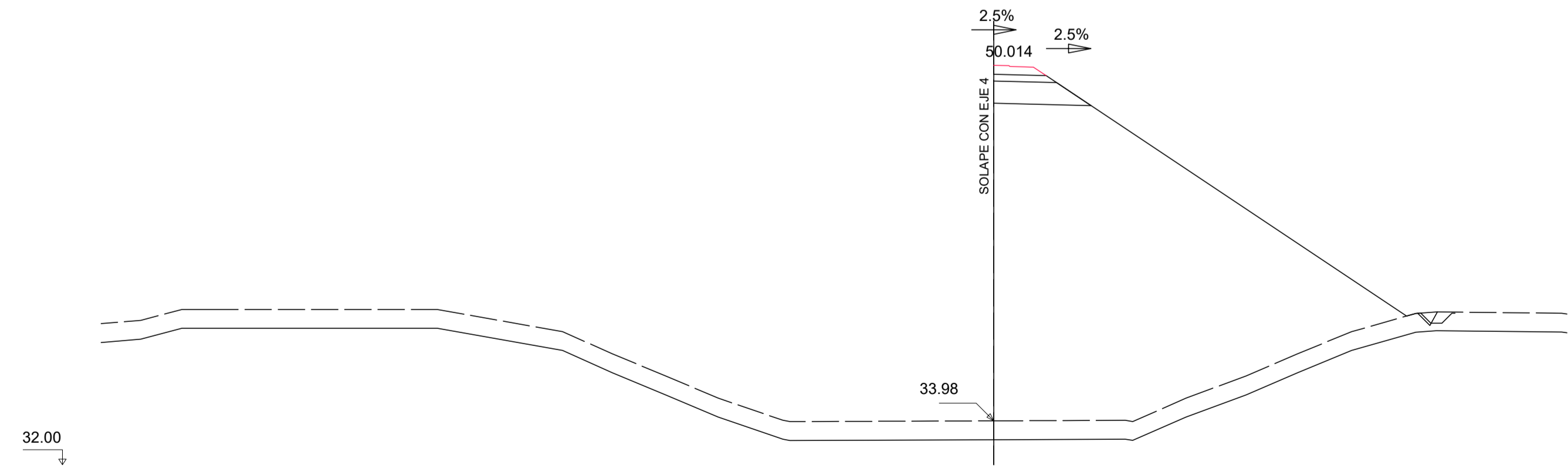

Pk=0+192.985
 S. FIRME = 0.80 m². S. REV CUN GUARDA = 0.07 m².
 S. SUELO ADEC = 3.60 m². S. VEGETAL = 17.00 m².
 S. SUELO S-EST3 = 0.78 m².
 S. TERRAPLEN = 183.43 m².

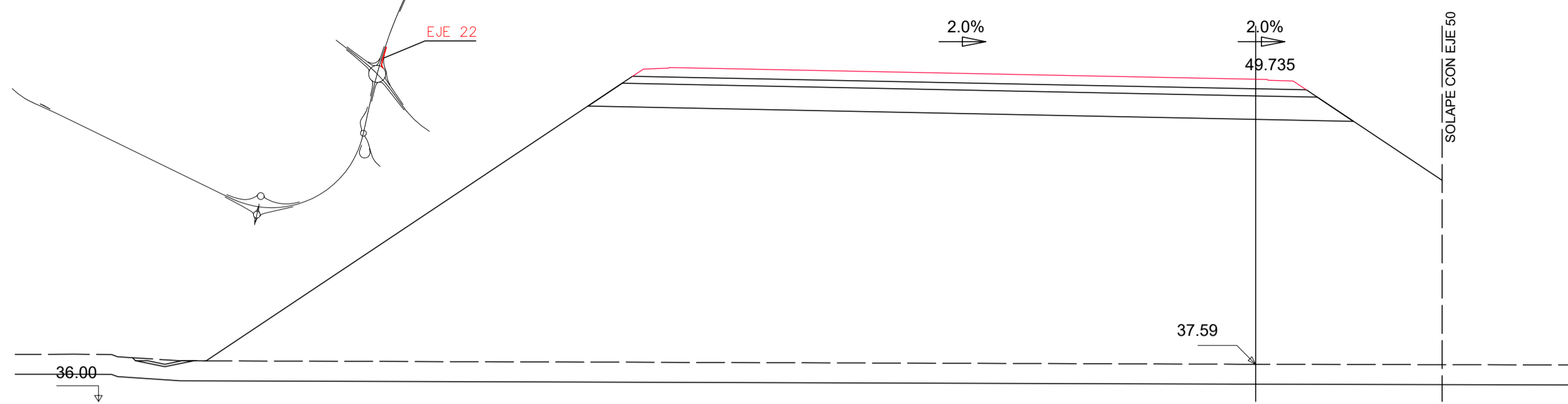

Pk=0+000
 S. FIRME = 11.42 m2. S. REV CUN GUARDA = 0.20 m2.
 S. SUELO ADEC = 31.13 m2. S. VEGETAL = 47.46 m2.
 S. SUELO S-EST3 = 8.75 m2.
 S. TERRAPLEN = 517.59 m2.

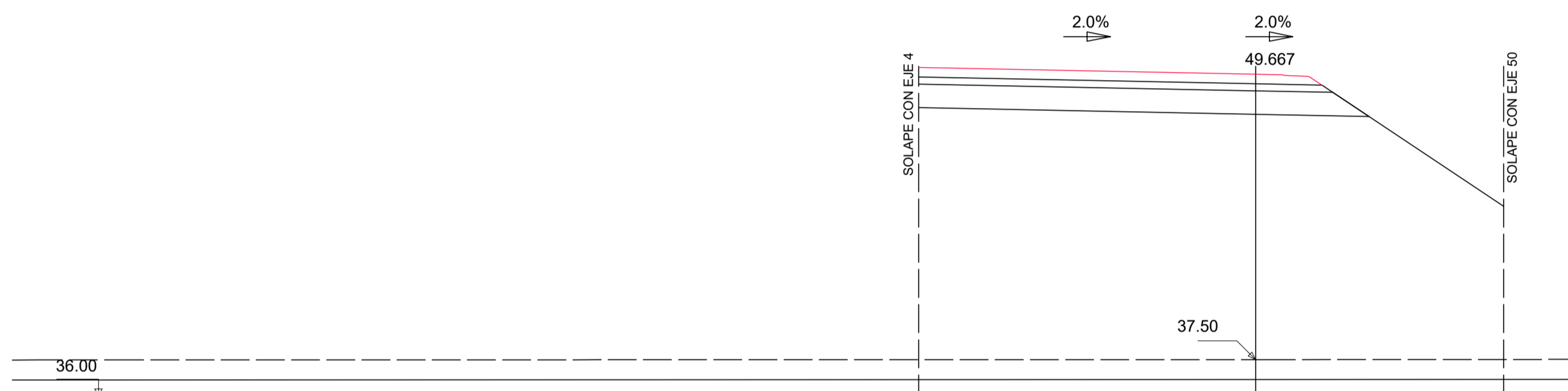

Pk=0+020
 S. FIRME = 6.88 m2. S. VEGETAL = 21.20 m2.
 S. SUELO ADEC = 18.43 m2.
 S. SUELO S-EST3 = 5.23 m2.
 S. TERRAPLEN = 272.23 m2.



Pk=0+040
 S. FIRME = 7.64 m2. S. VEGETAL = 19.82 m2.
 S. SUELO ADEC = 20.29 m2.
 S. SUELO S-EST3 = 5.79 m2.
 S. TERRAPLEN = 262.31 m2.

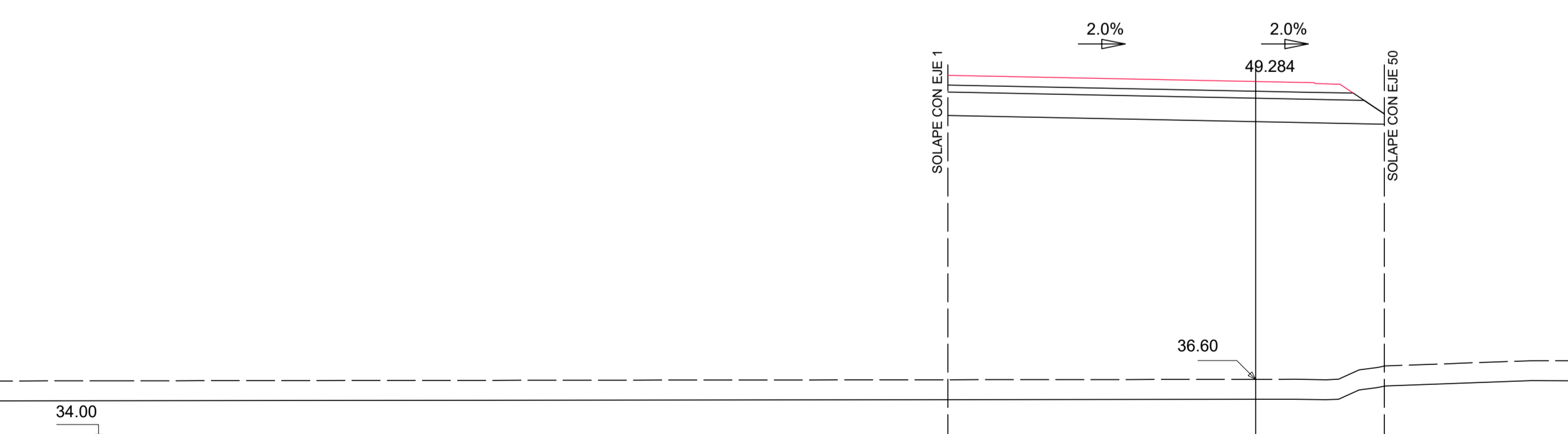

Pk=0+060
 S. FIRME = 6.92 m2. S. VEGETAL = 15.82 m2.
 S. SUELO ADEC = 18.37 m2.
 S. SUELO S-EST3 = 5.25 m2.
 S. TERRAPLEN = 220.98 m2.

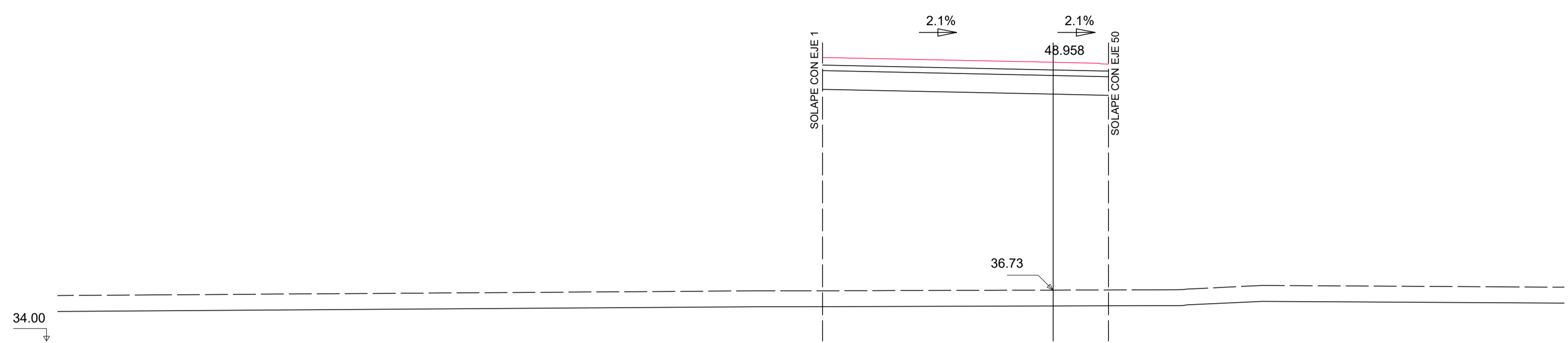

Pk=0+080
 S. FIRME = 6.27 m2. S. VEGETAL = 13.04 m2.
 S. SUELO ADEC = 15.34 m2.
 S. SUELO S-EST3 = 4.60 m2.
 S. TERRAPLEN = 176.09 m2.

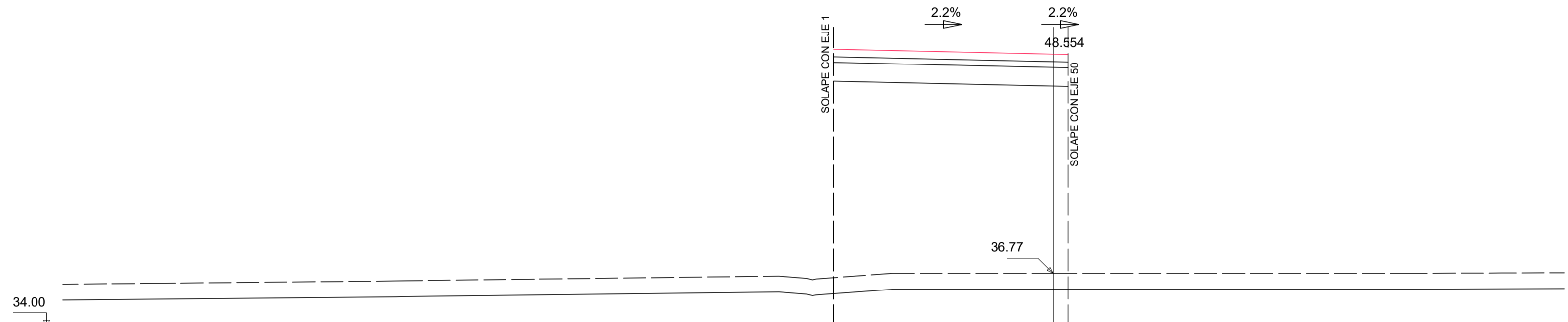

Pk=0+100
 S. FIRME = 5.15 m2. S. VEGETAL = 10.68 m2.
 S. SUELO ADEC = 12.56 m2.
 S. SUELO S-EST3 = 3.77 m2.
 S. TERRAPLEN = 139.05 m2.

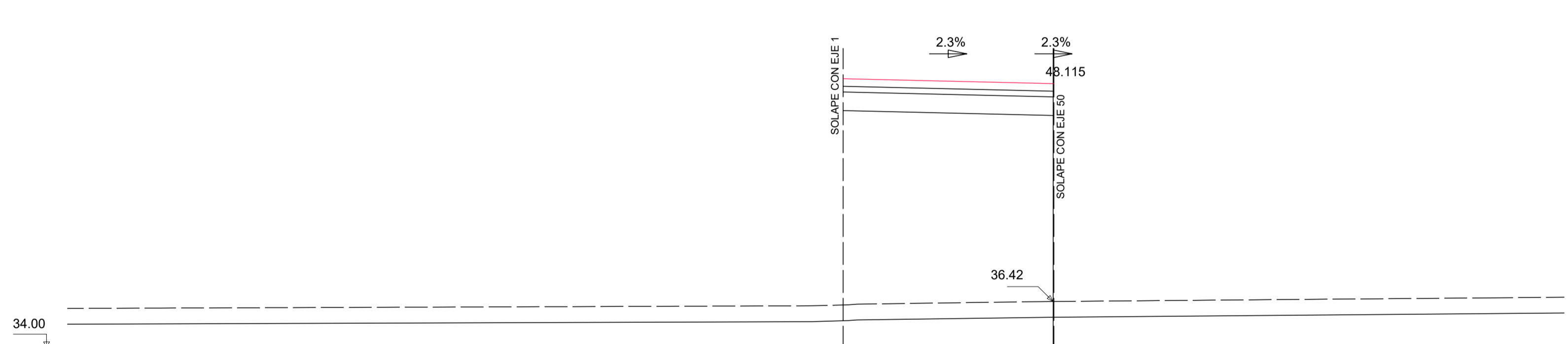

Pk=0+120
 S. FIRME = 4.64 m2. S. VEGETAL = 9.61 m2.
 S. SUELO ADEC = 11.31 m2.
 S. SUELO S-EST3 = 3.39 m2.
 S. TERRAPLEN = 124.81 m2.



Pk=0+140
 S. FIRME = 7.27 m2. S. REV CUN GUARDA = 0.20 m2.
 S. SUELO ADEC = 19.38 m2. S. VEGETAL = 31.53 m2.
 S. SUELO S-EST3 = 5.51 m2.
 S. TERRAPLEN = 293.96 m2.

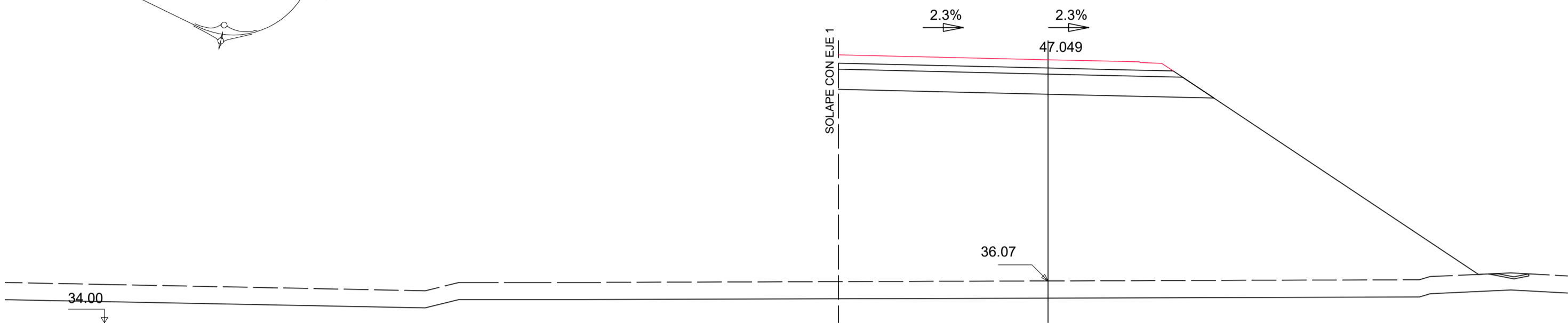
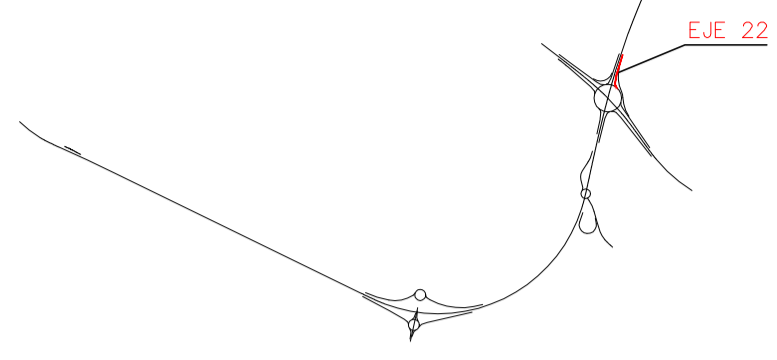

Pk=0+160
 S. FIRME = 6.64 m². S. REV CUN GUARDA = 0.18 m².
 S. SUELO ADEC = 17.85 m². S. VEGETAL = 29.11 m².
 S. SUELO S-EST3 = 5.05 m².
 S. TERRAPLEN = 262.37 m².

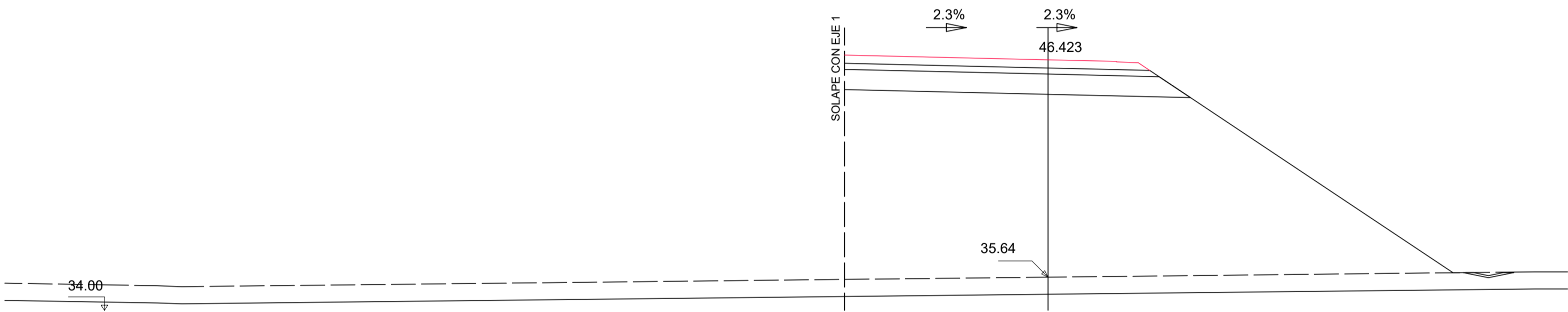

Pk=0+180
 S. FIRME = 6.04 m². S. REV CUN GUARDA = 0.20 m².
 S. SUELO ADEC = 16.38 m². S. VEGETAL = 28.23 m².
 S. SUELO S-EST3 = 4.61 m².
 S. TERRAPLEN = 241.88 m².

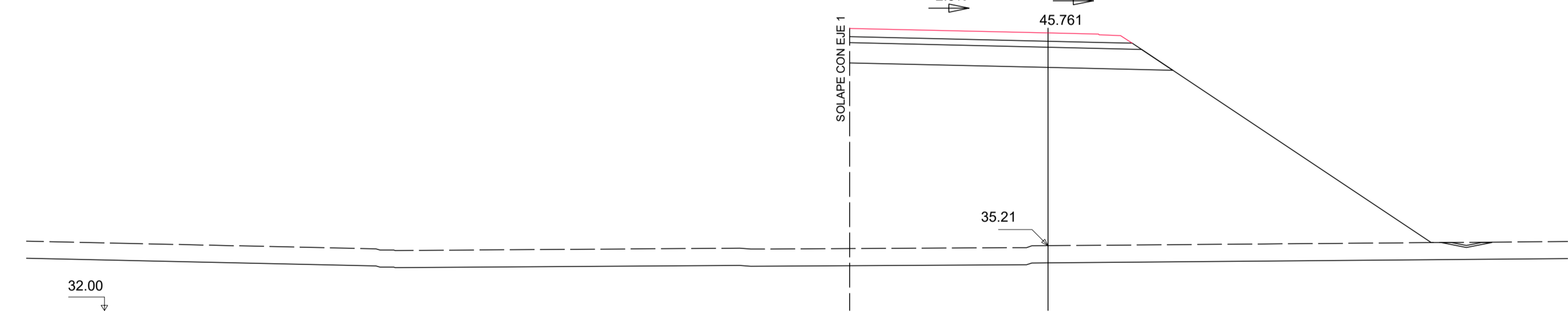

Pk=0+200
 S. FIRME = 5.58 m². S. REV CUN GUARDA = 0.20 m².
 S. SUELO ADEC = 15.25 m². S. VEGETAL = 27.09 m².
 S. SUELO S-EST3 = 4.27 m².
 S. TERRAPLEN = 225.40 m².

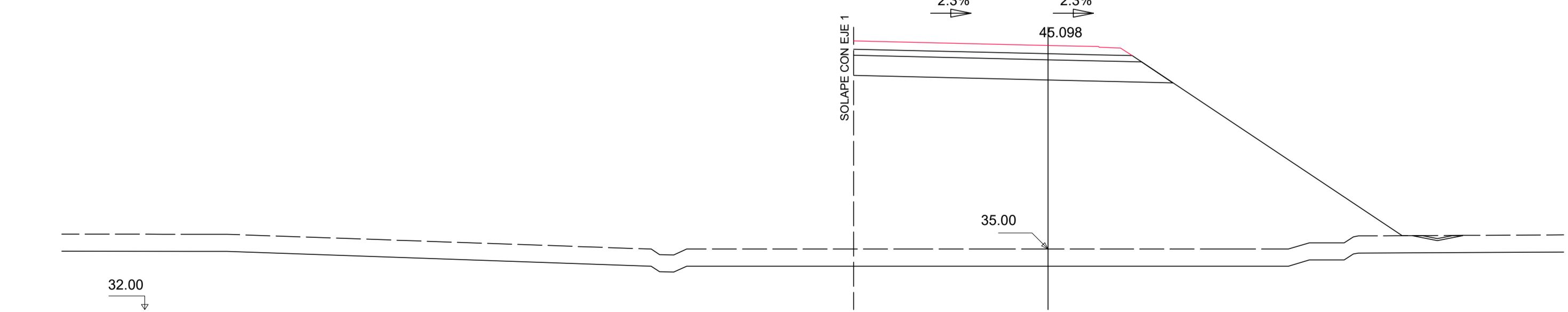

Pk=0+220
 S. FIRME = 5.50 m². S. REV CUN GUARDA = 0.20 m².
 S. SUELO ADEC = 15.06 m². S. VEGETAL = 25.69 m².
 S. SUELO S-EST3 = 4.21 m².
 S. TERRAPLEN = 206.99 m².

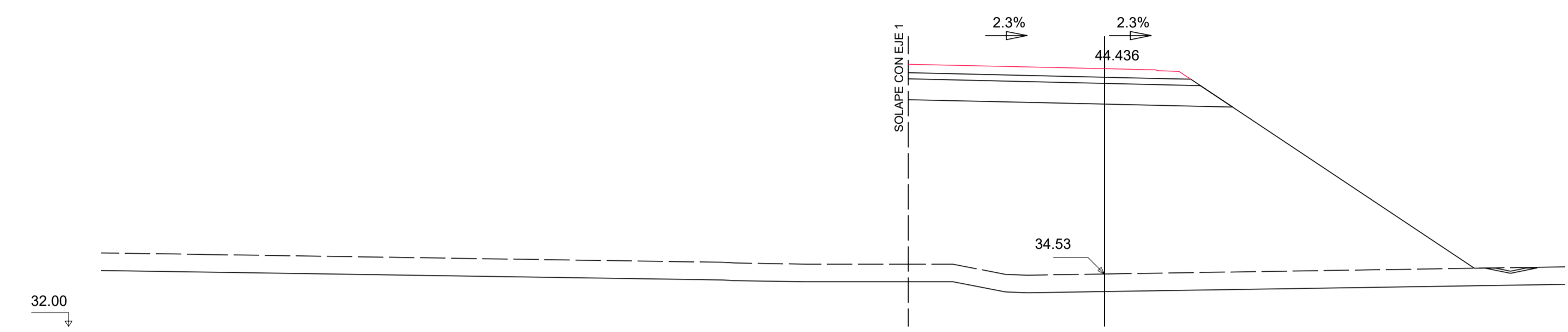

Pk=0+240
 S. FIRME = 5.42 m². S. REV CUN GUARDA = 0.20 m².
 S. SUELO ADEC = 14.89 m². S. VEGETAL = 25.81 m².
 S. SUELO S-EST3 = 4.16 m².
 S. TERRAPLEN = 199.13 m².

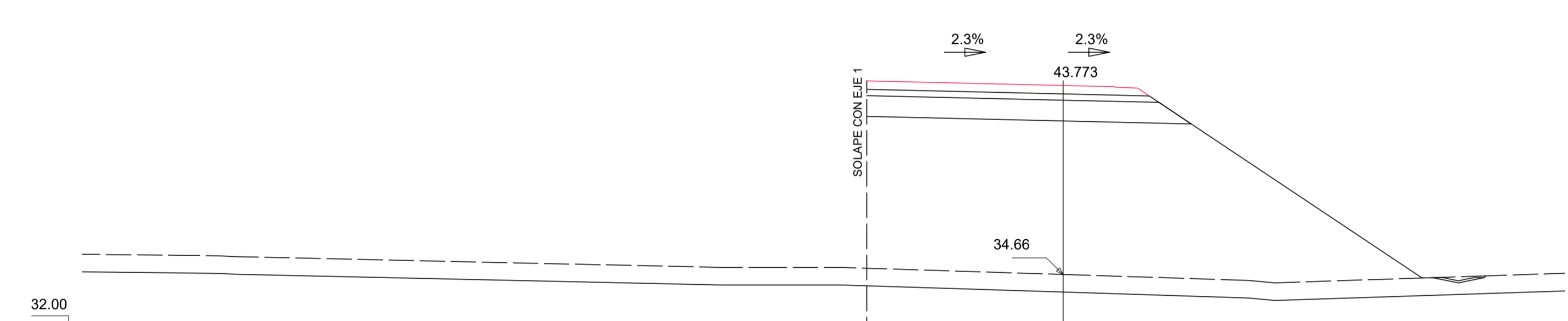

Pk=0+260
 S. FIRME = 5.42 m². S. REV CUN GUARDA = 0.20 m².
 S. SUELO ADEC = 14.88 m². S. VEGETAL = 25.40 m².
 S. SUELO S-EST3 = 4.16 m².
 S. TERRAPLEN = 183.32 m².

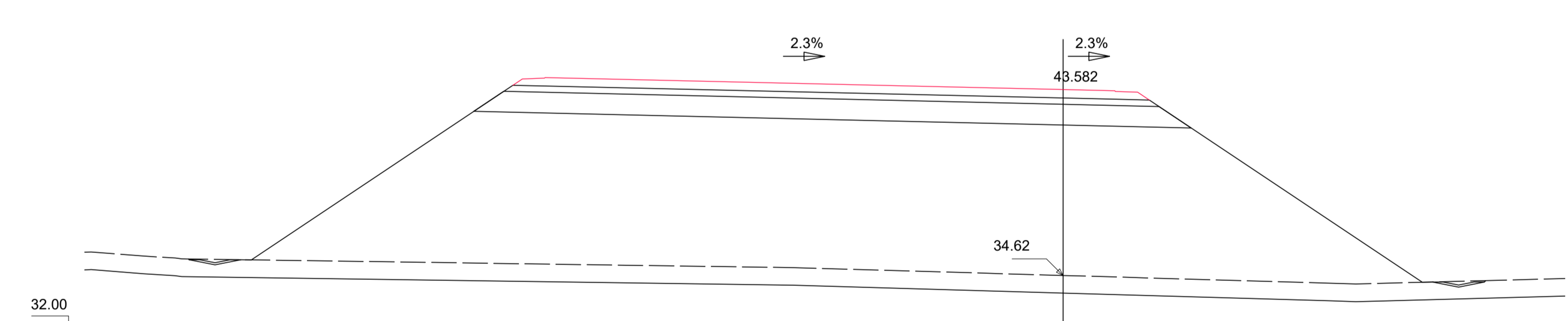

Pk=0+265.753
 S. FIRME = 12.24 m². S. REV CUN GUARDA = 0.41 m².
 S. SUELO ADEC = 33.13 m². S. VEGETAL = 53.23 m².
 S. SUELO S-EST3 = 9.35 m².
 S. TERRAPLEN = 383.68 m².

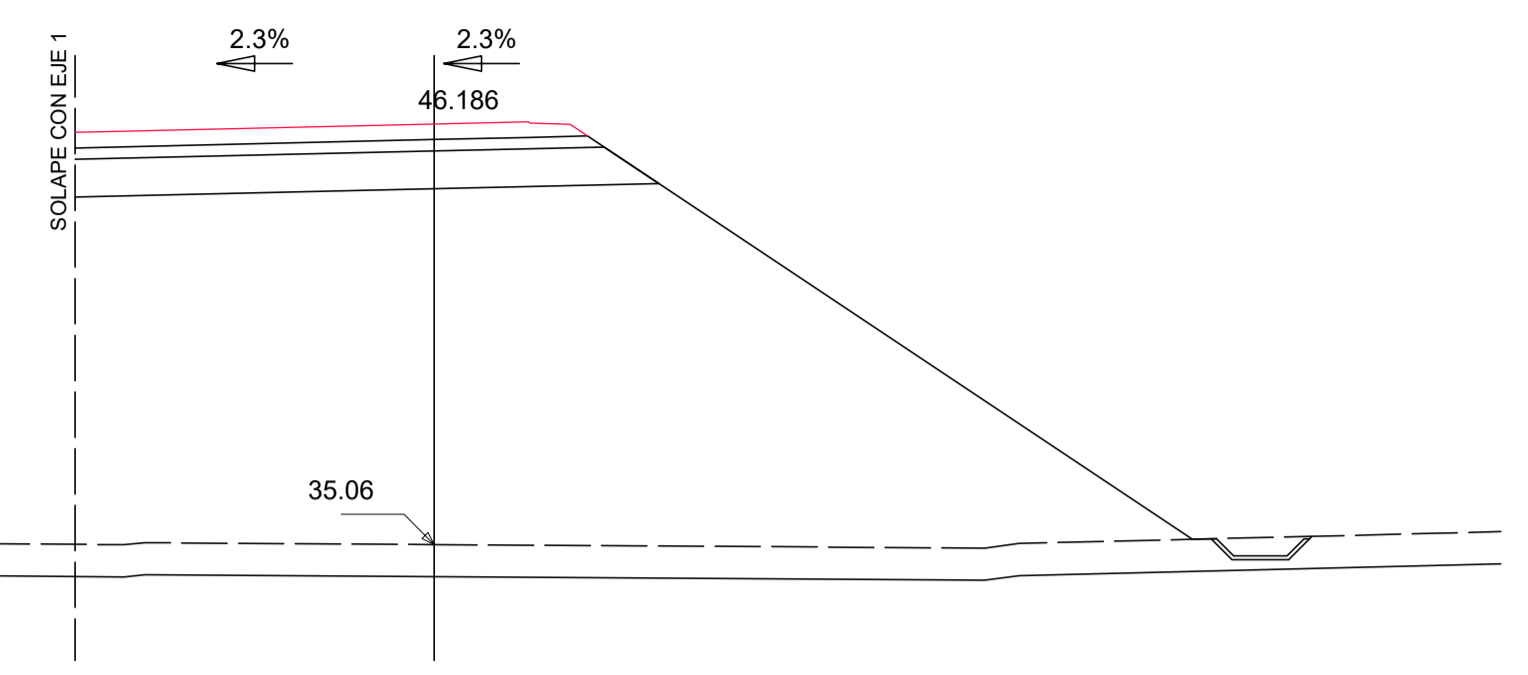
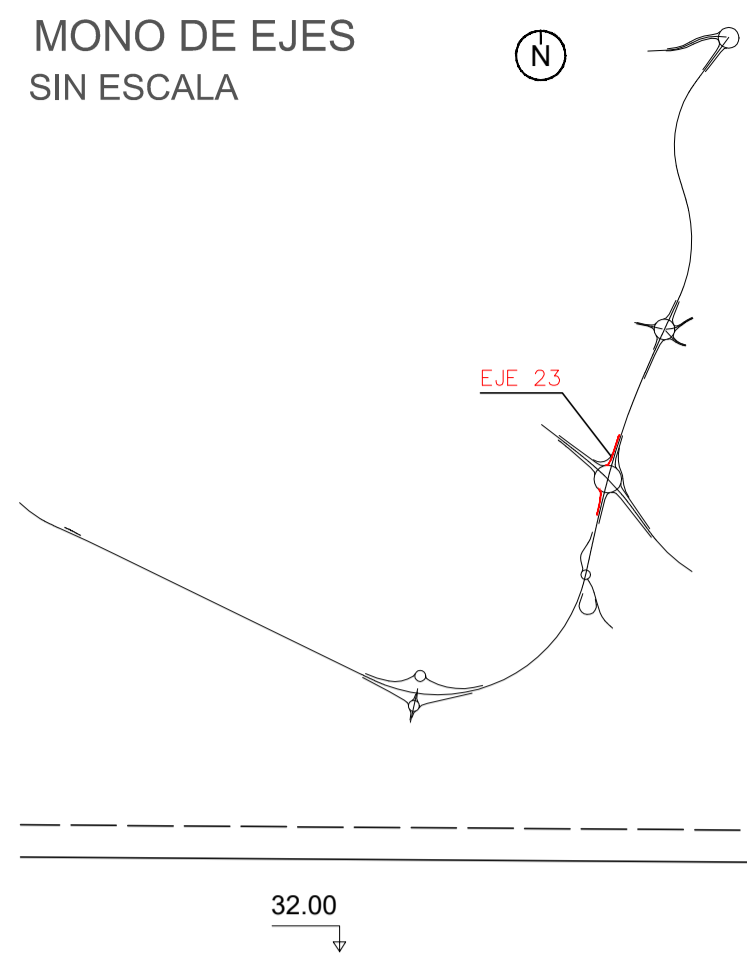

Pk=0+000
 S. FIRME = 5.38 m2. S. REV CUN GUARDA = 0.29 m2.
 S. SUELO ADEC = 14.72 m2. S. VEGETAL = 27.81 m2.
 S. SUELO S-EST3 = 4.13 m2.
 S. TERRAPLEN = 239.79 m2.

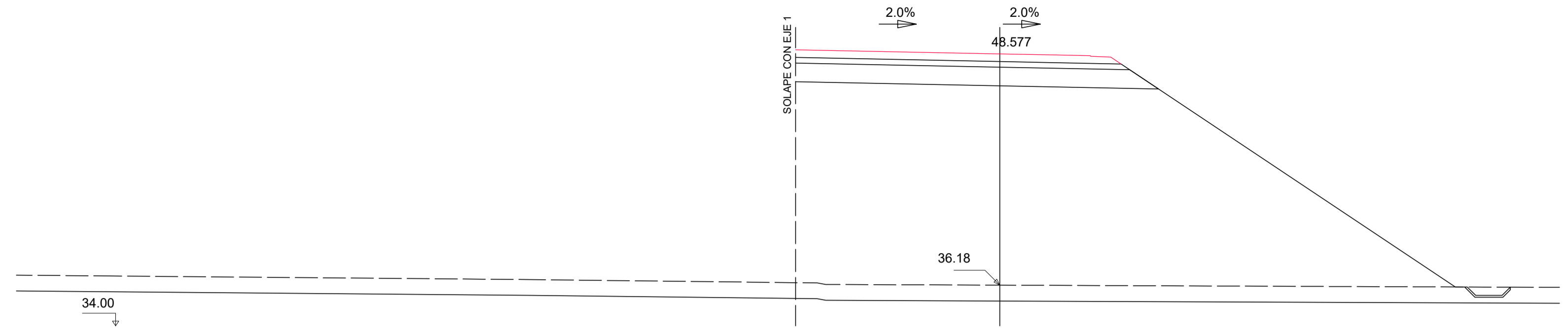

Pk=0+080
 S. FIRME = 6.99 m2. S. REV CUN GUARDA = 0.28 m2.
 S. SUELO ADEC = 18.70 m2. S. VEGETAL = 32.59 m2.
 S. SUELO S-EST3 = 5.31 m2.
 S. TERRAPLEN = 323.85 m2.

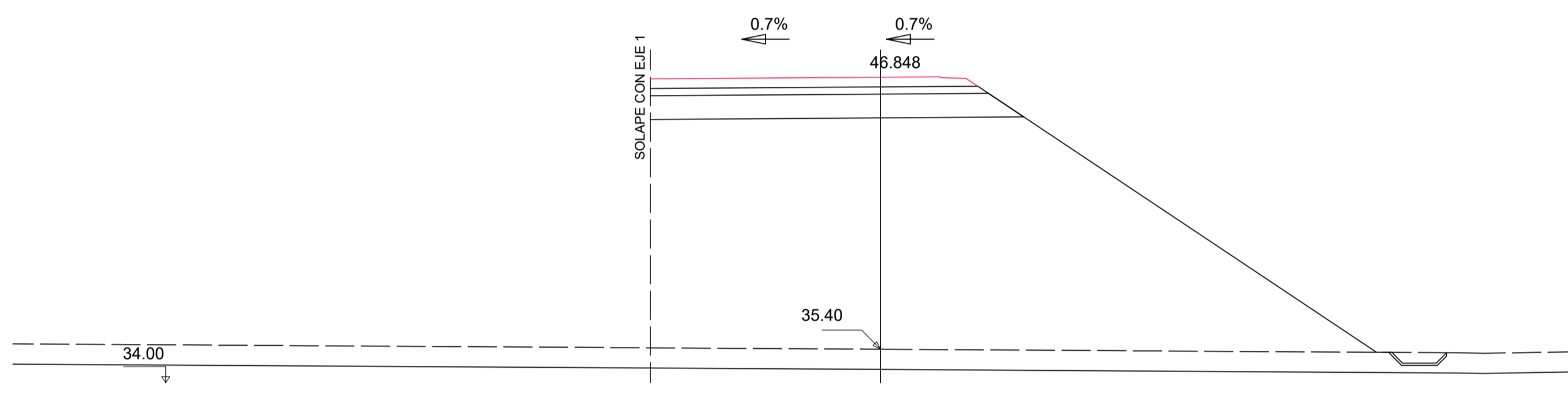

Pk=0+020
 S. FIRME = 5.47 m2. S. REV CUN GUARDA = 0.28 m2.
 S. SUELO ADEC = 14.97 m2. S. VEGETAL = 28.49 m2.
 S. SUELO S-EST3 = 4.20 m2.
 S. TERRAPLEN = 252.88 m2.

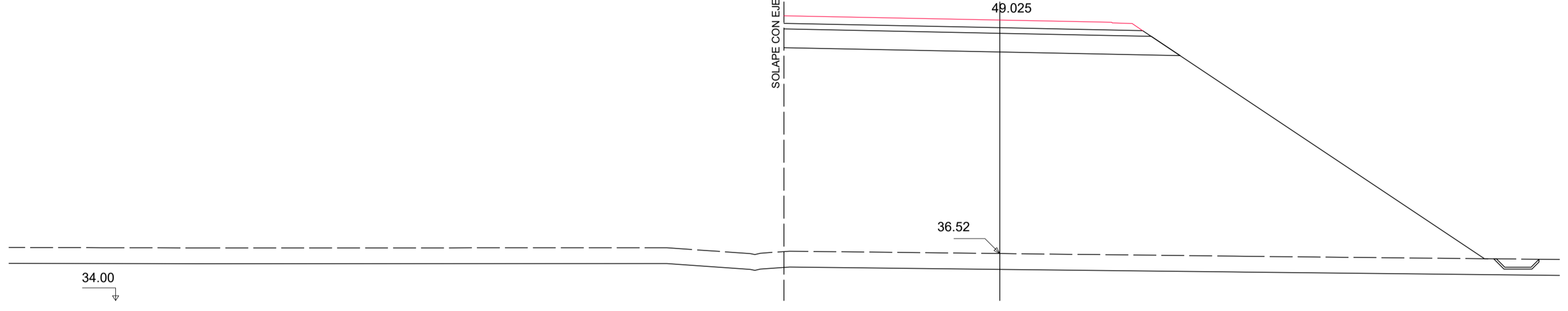

Pk=0+100
 S. FIRME = 7.72 m2. S. REV CUN GUARDA = 0.27 m2.
 S. SUELO ADEC = 20.48 m2. S. VEGETAL = 34.43 m2.
 S. SUELO S-EST3 = 5.84 m2.
 S. TERRAPLEN = 350.51 m2.

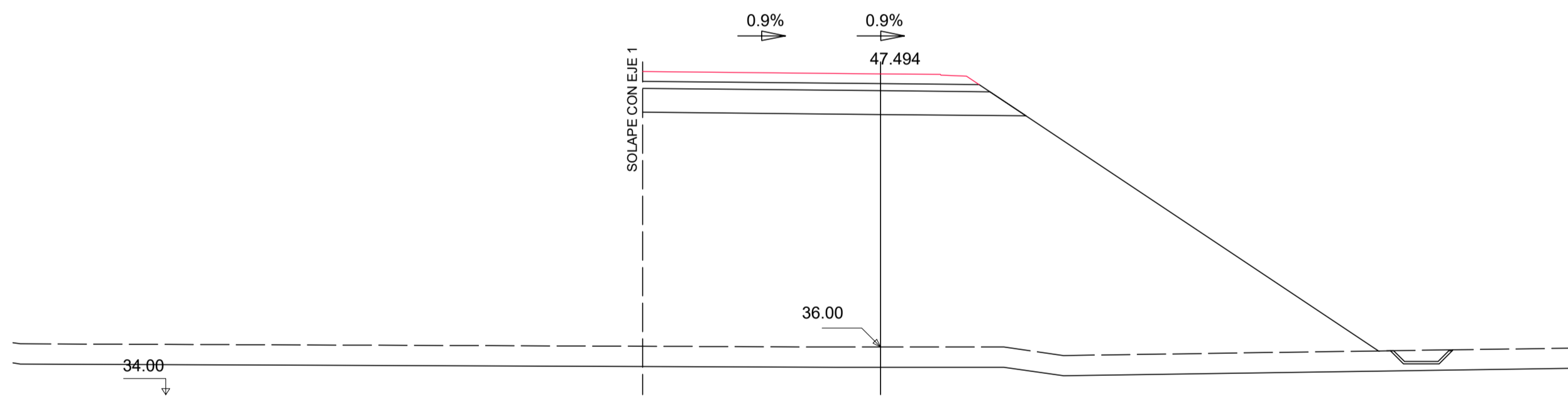

Pk=0+040
 S. FIRME = 5.63 m2. S. REV CUN GUARDA = 0.29 m2.
 S. SUELO ADEC = 15.38 m2. S. VEGETAL = 29.00 m2.
 S. SUELO S-EST3 = 4.32 m2.
 S. TERRAPLEN = 260.73 m2.

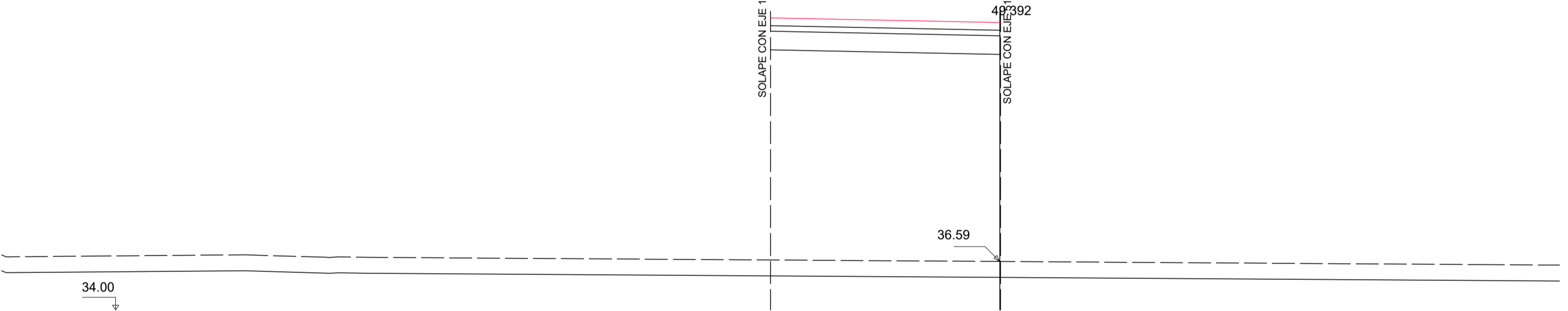

Pk=0+120
 S. FIRME = 5.06 m2. S. VEGETAL = 10.49 m2.
 S. SUELO ADEC = 12.34 m2.
 S. SUELO S-EST3 = 3.70 m2.
 S. TERRAPLEN = 148.40 m2.

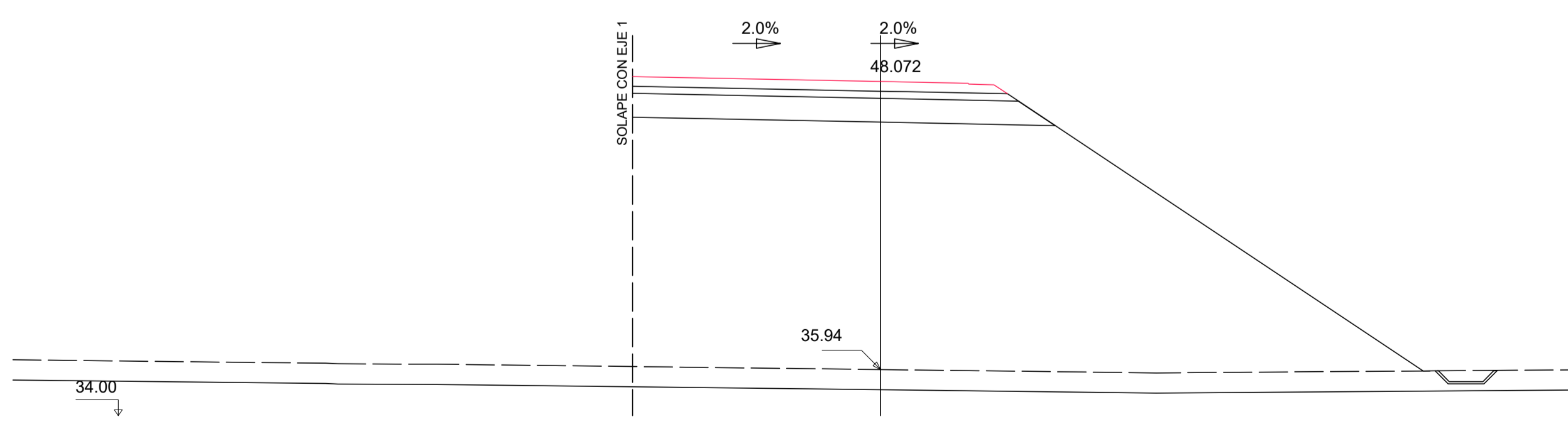

Pk=0+060
 S. FIRME = 6.30 m2. S. REV CUN GUARDA = 0.29 m2.
 S. SUELO ADEC = 17.01 m2. S. VEGETAL = 30.94 m2.
 S. SUELO S-EST3 = 4.80 m2.
 S. TERRAPLEN = 296.09 m2.



Pk=0+140
 S. FIRME = 6.37 m2. S. VEGETAL = 13.23 m2.
 S. SUELO ADEC = 15.57 m2.
 S. SUELO S-EST3 = 4.67 m2.
 S. TERRAPLEN = 190.05 m2.

MONO DE EJES
SIN ESCALA

(N)

EJE 23 (HOJA 02 DE 02)

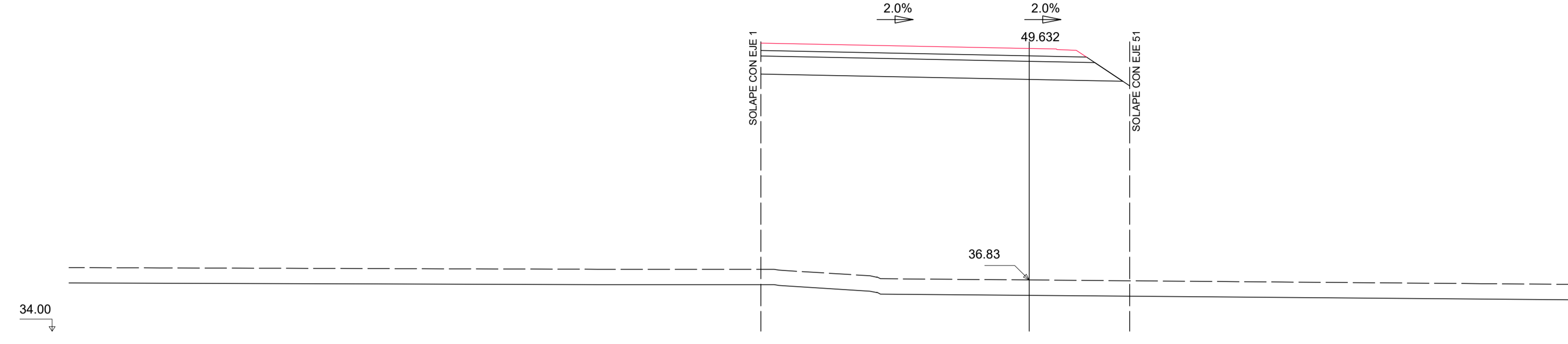
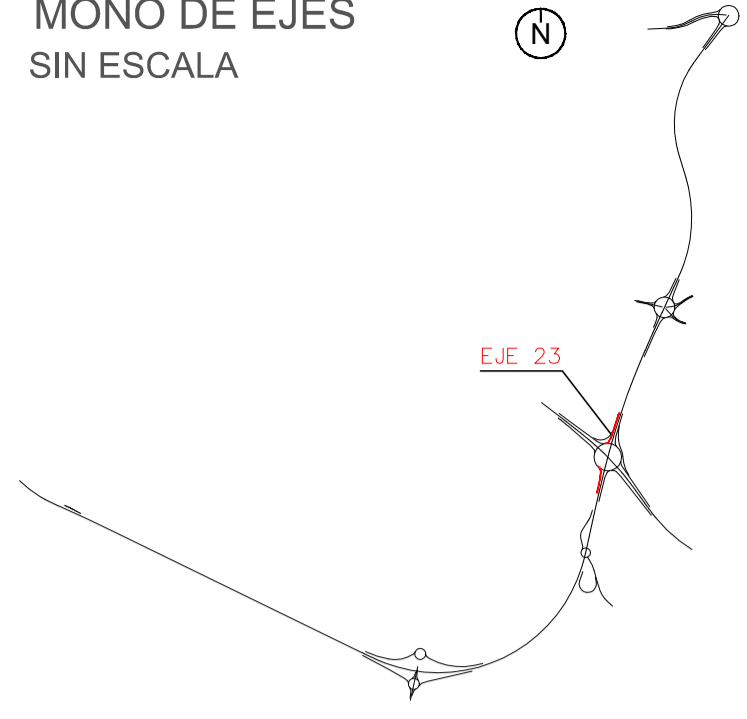

Pk=0+160
 S. FIRME = 7.21 m2. S. VEGETAL = 17.33 m2.
 S. SUELO ADEC = 19.23 m2.
 S. SUELO S-EST3 = 5.47 m2.
 S. TERRAPLEN = 242.44 m2.

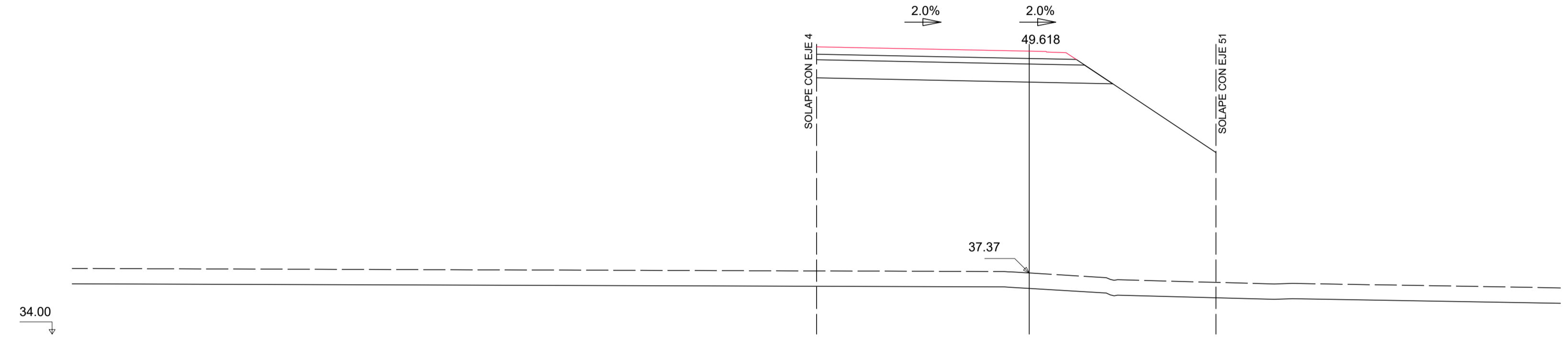

Pk=0+180
 S. FIRME = 5.71 m2. S. VEGETAL = 18.76 m2.
 S. SUELO ADEC = 15.59 m2.
 S. SUELO S-EST3 = 4.37 m2.
 S. TERRAPLEN = 243.30 m2.

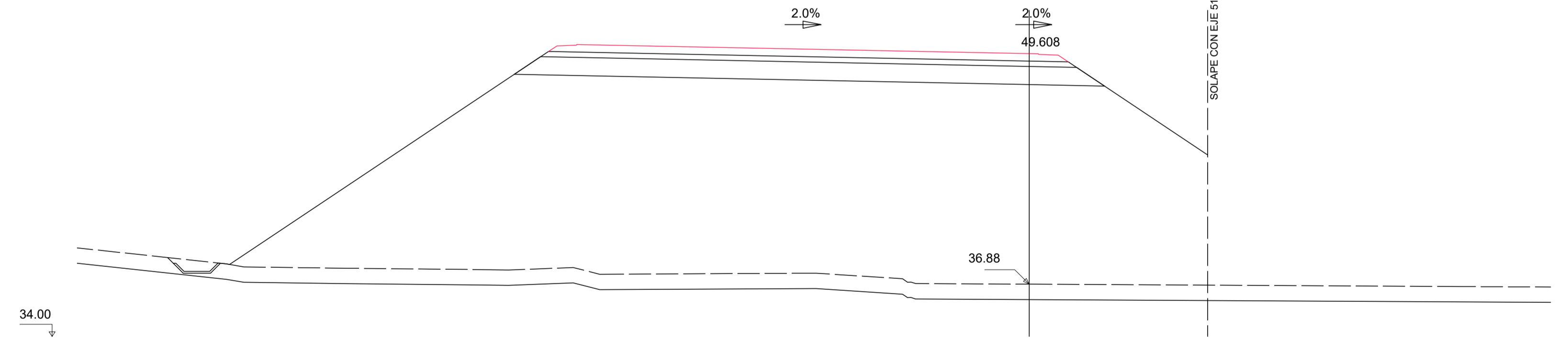

Pk=0+195.494
 S. FIRME = 11.42 m2. S. REV CUN GUARDA = 0.29 m2.
 S. SUELO ADEC = 31.12 m2. S. VEGETAL = 48.86 m2.
 S. SUELO S-EST3 = 8.75 m2.
 S. TERRAPLEN = 539.27 m2.

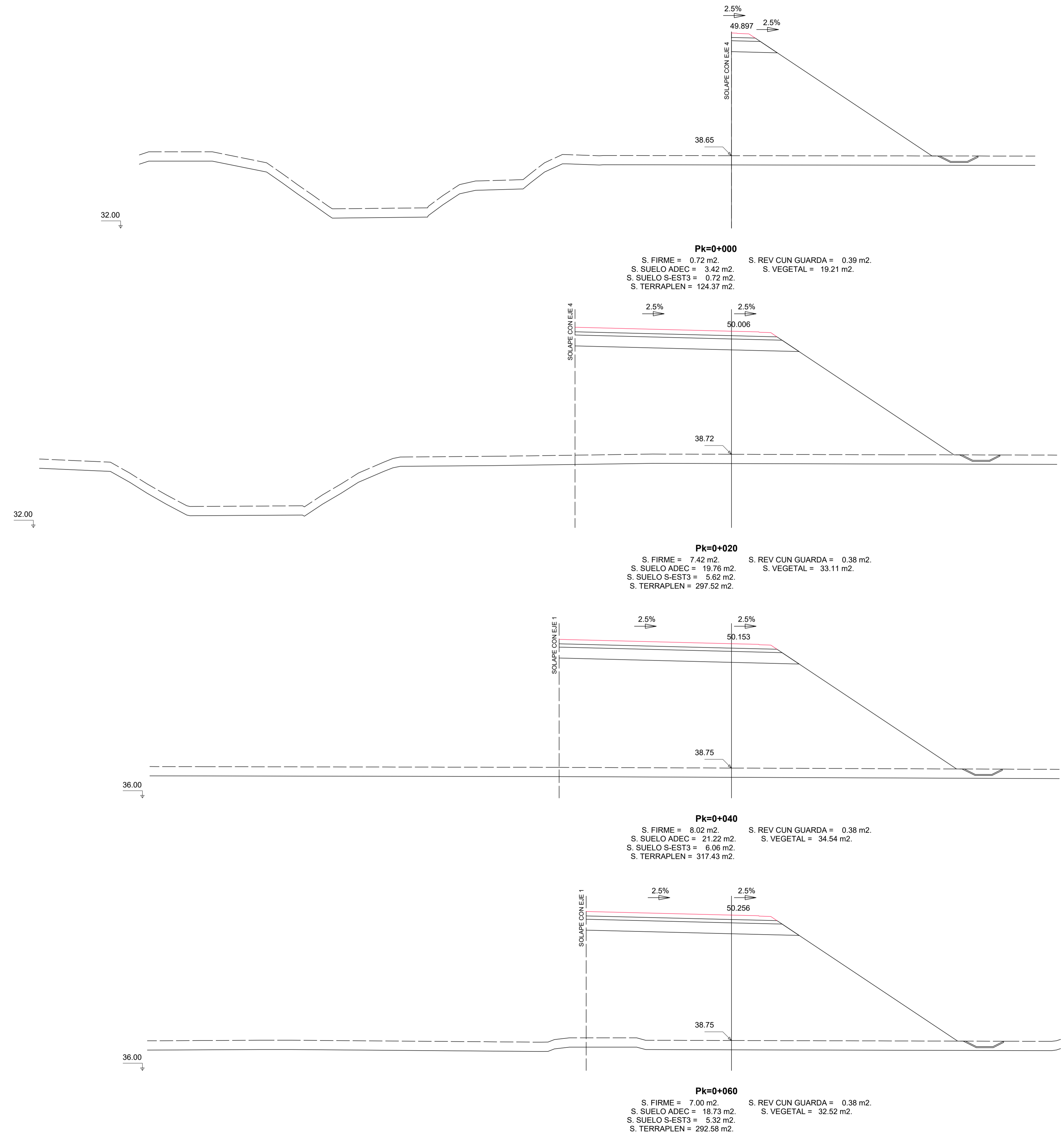

MONO DE EJES
SIN ESCALA

(N)

EJE 24 (HOJA 02 DE 02)

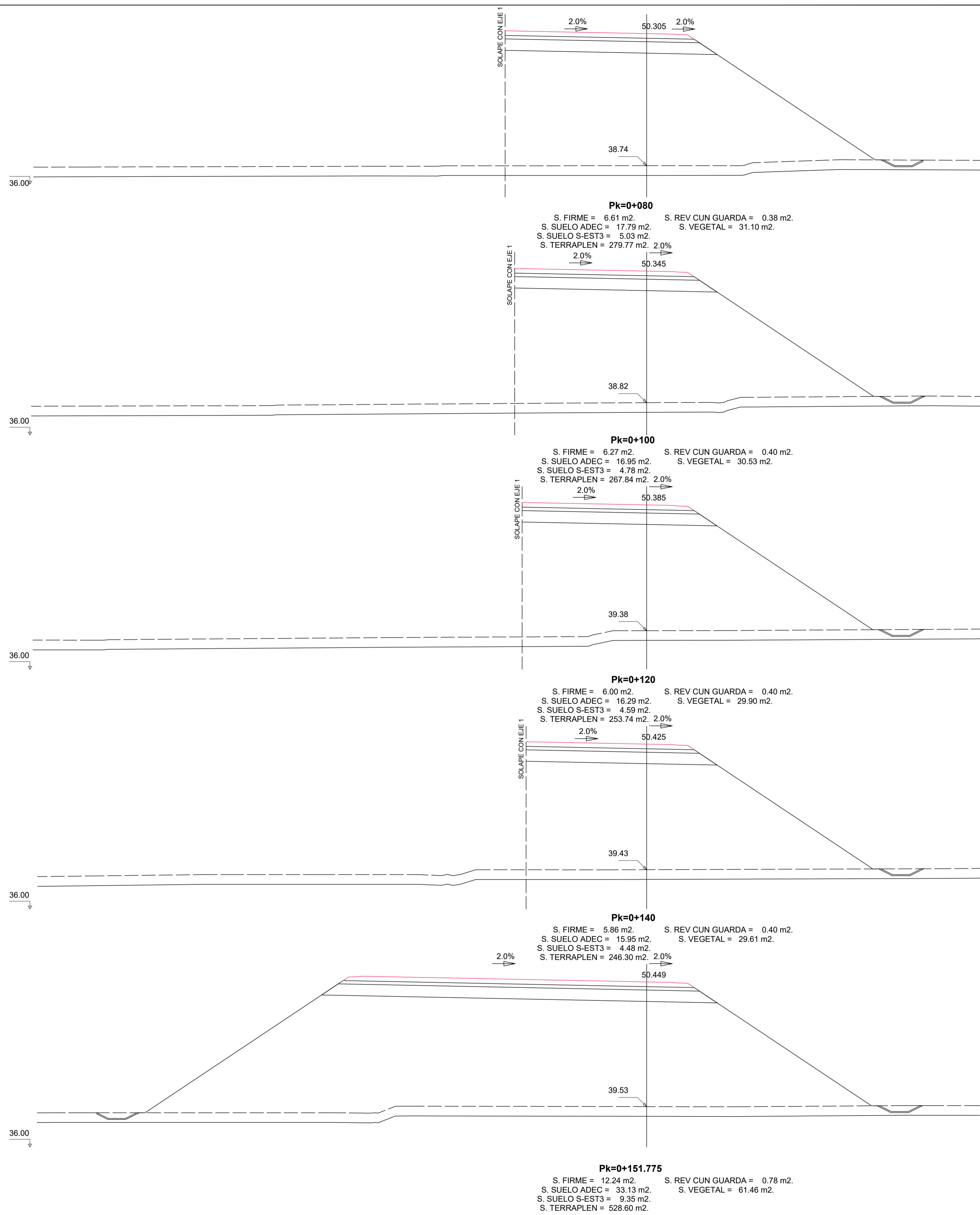

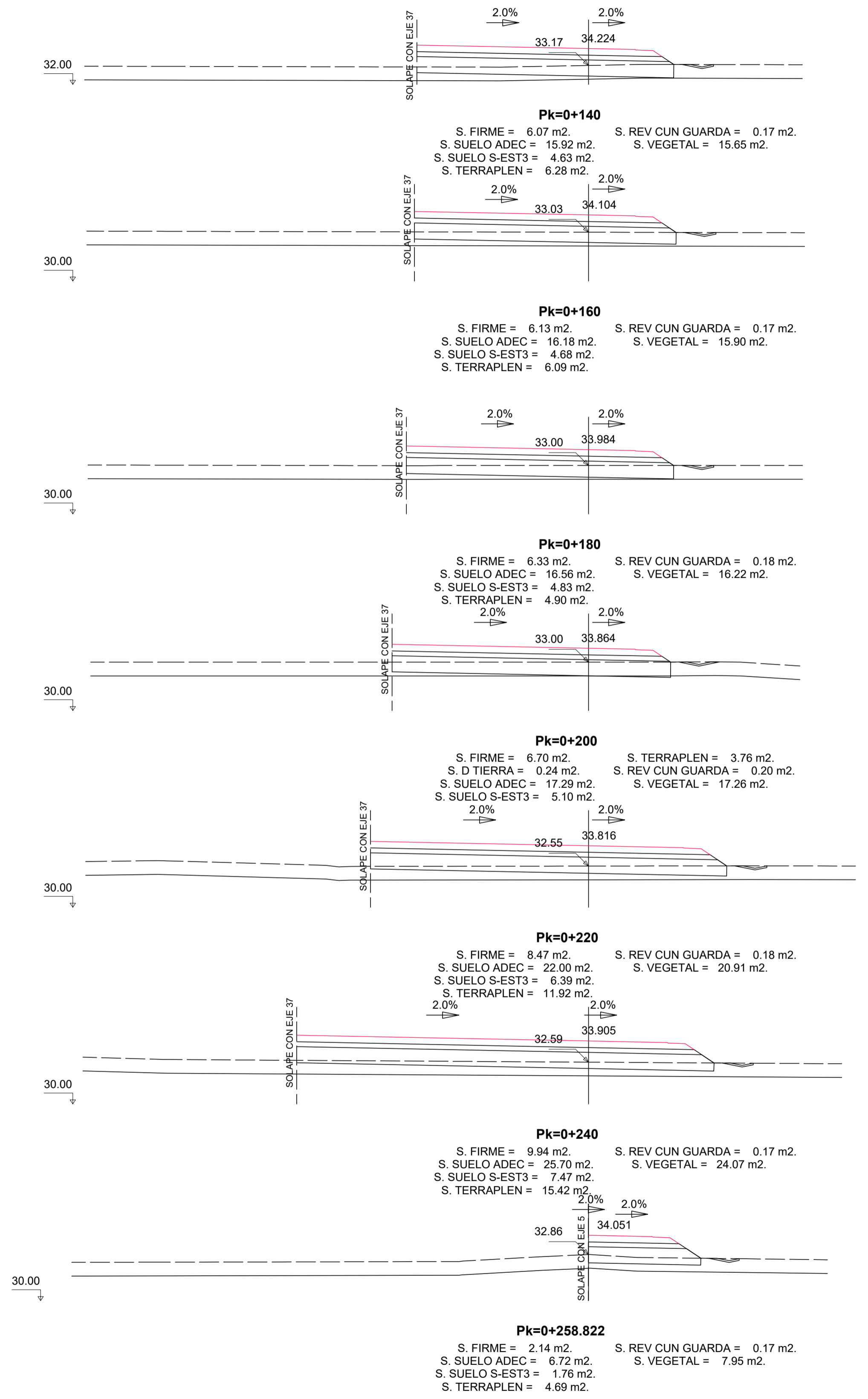
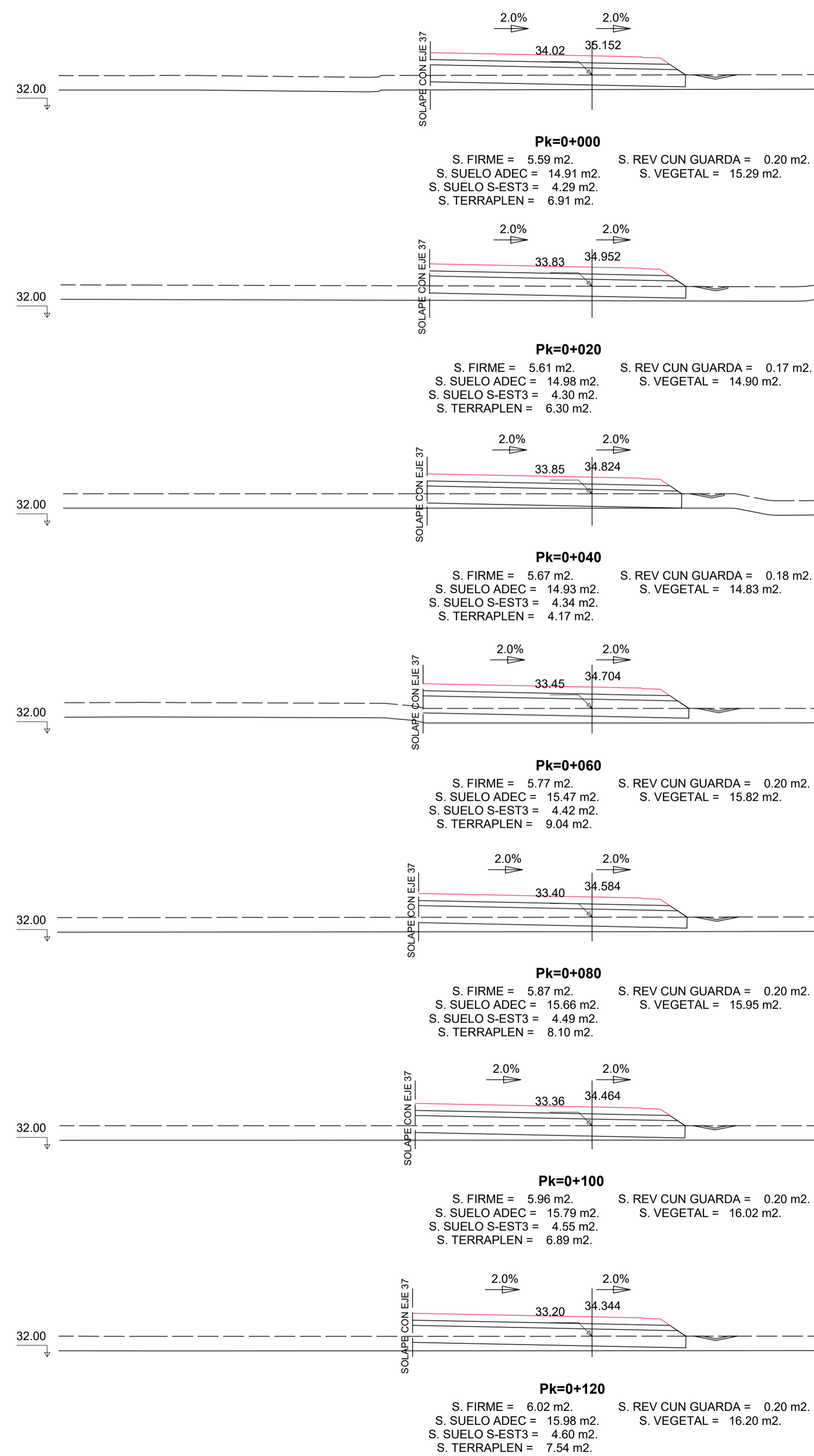
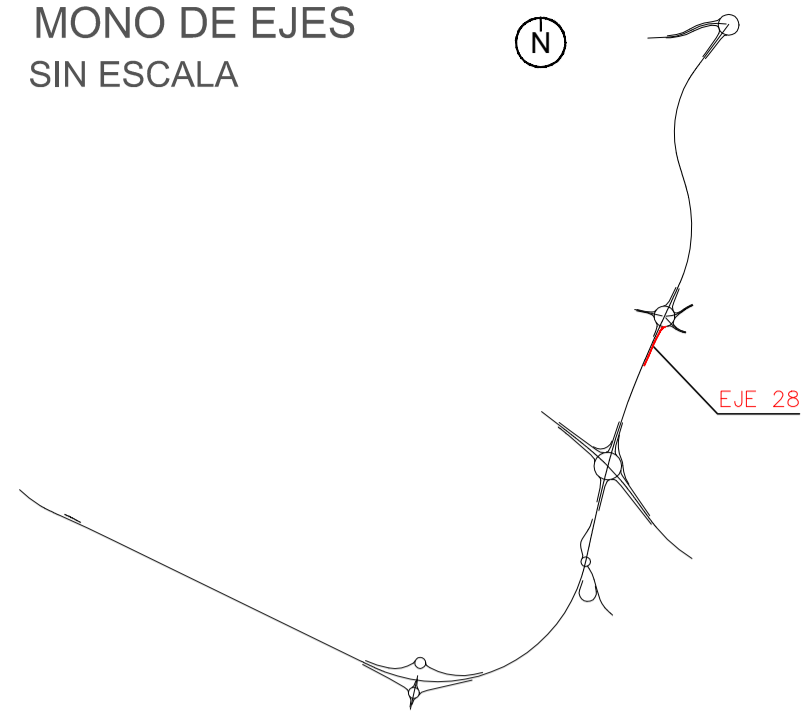

EJE 29

EJE 30

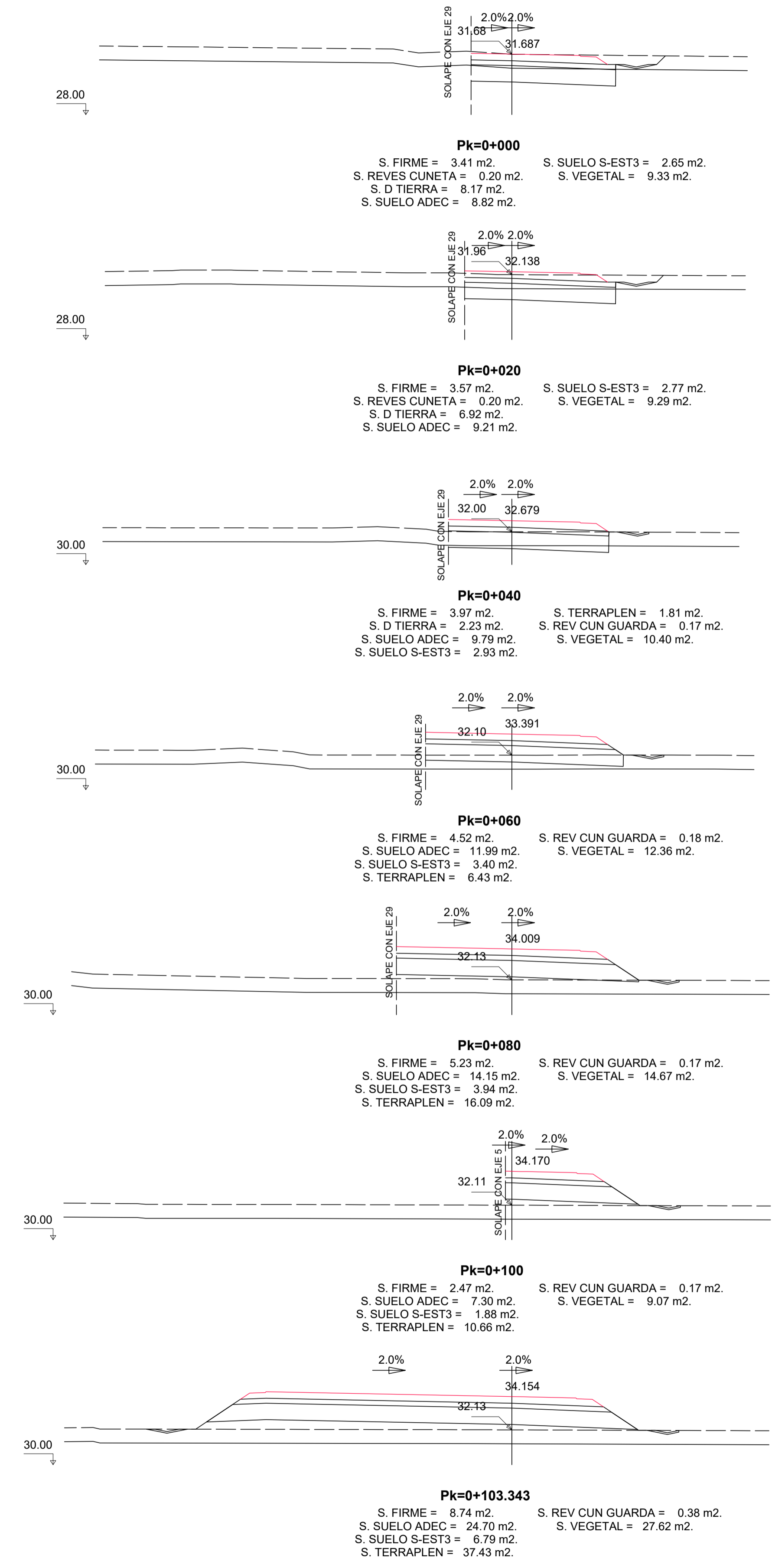
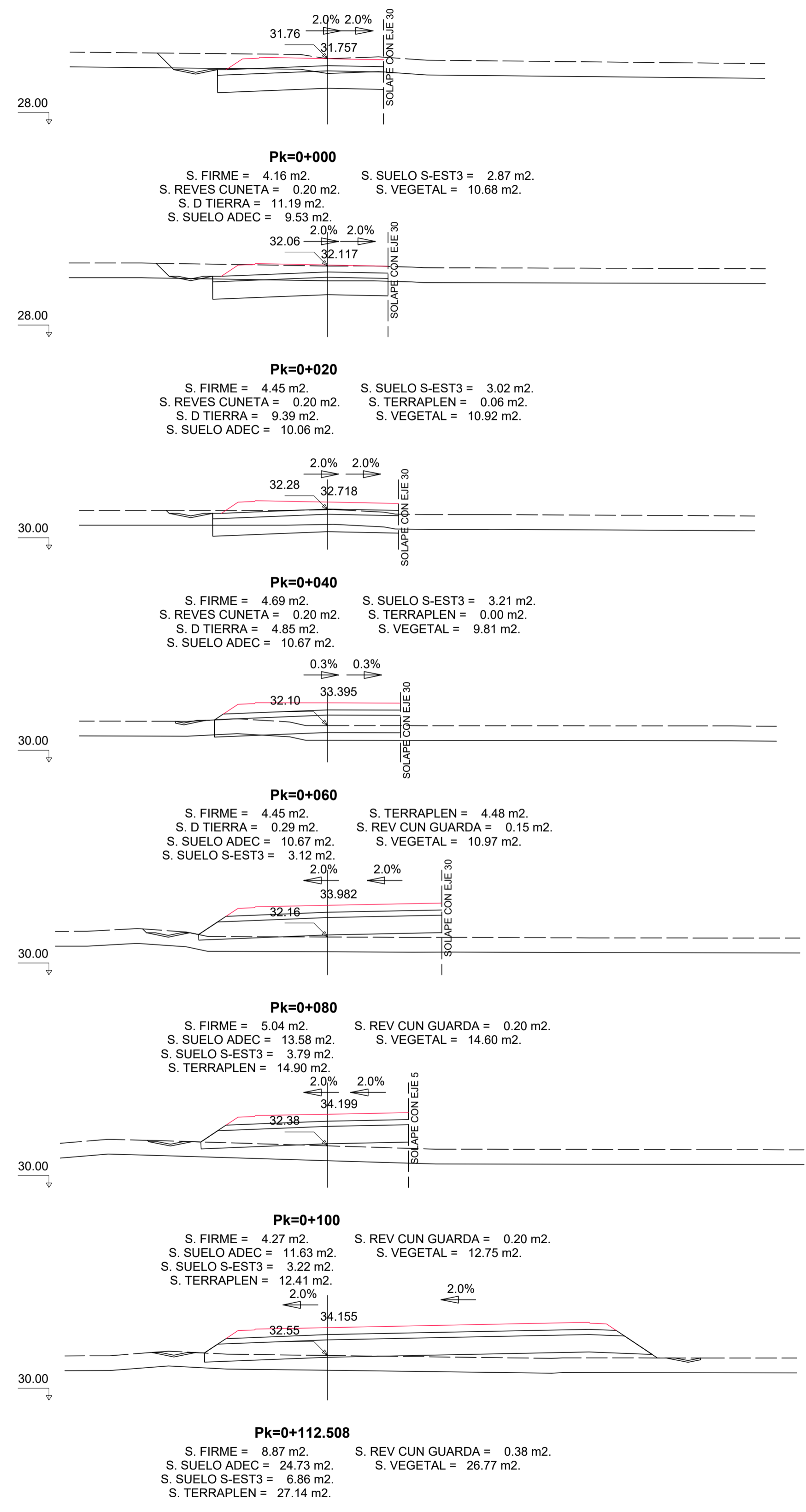
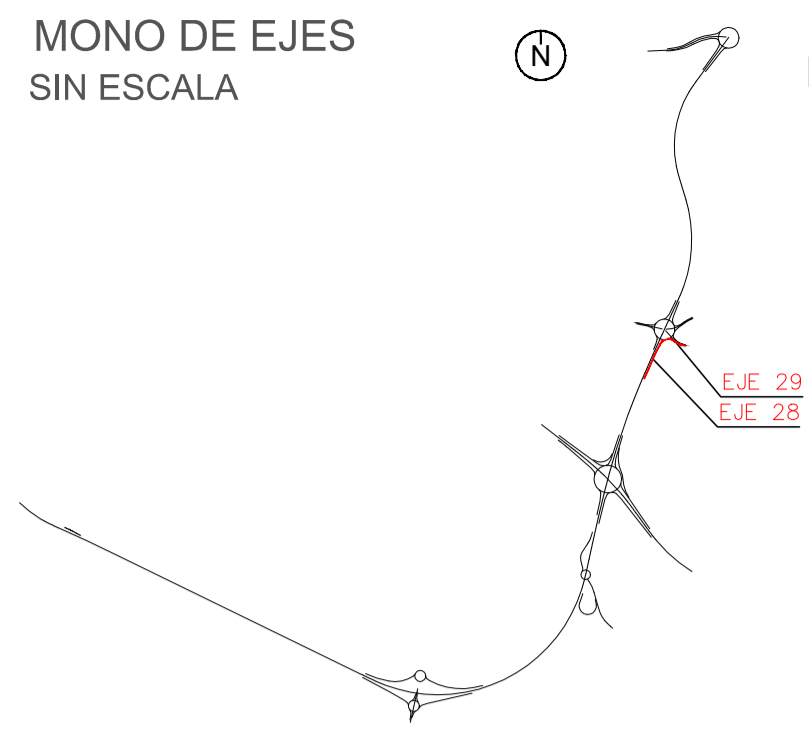



EJE 31

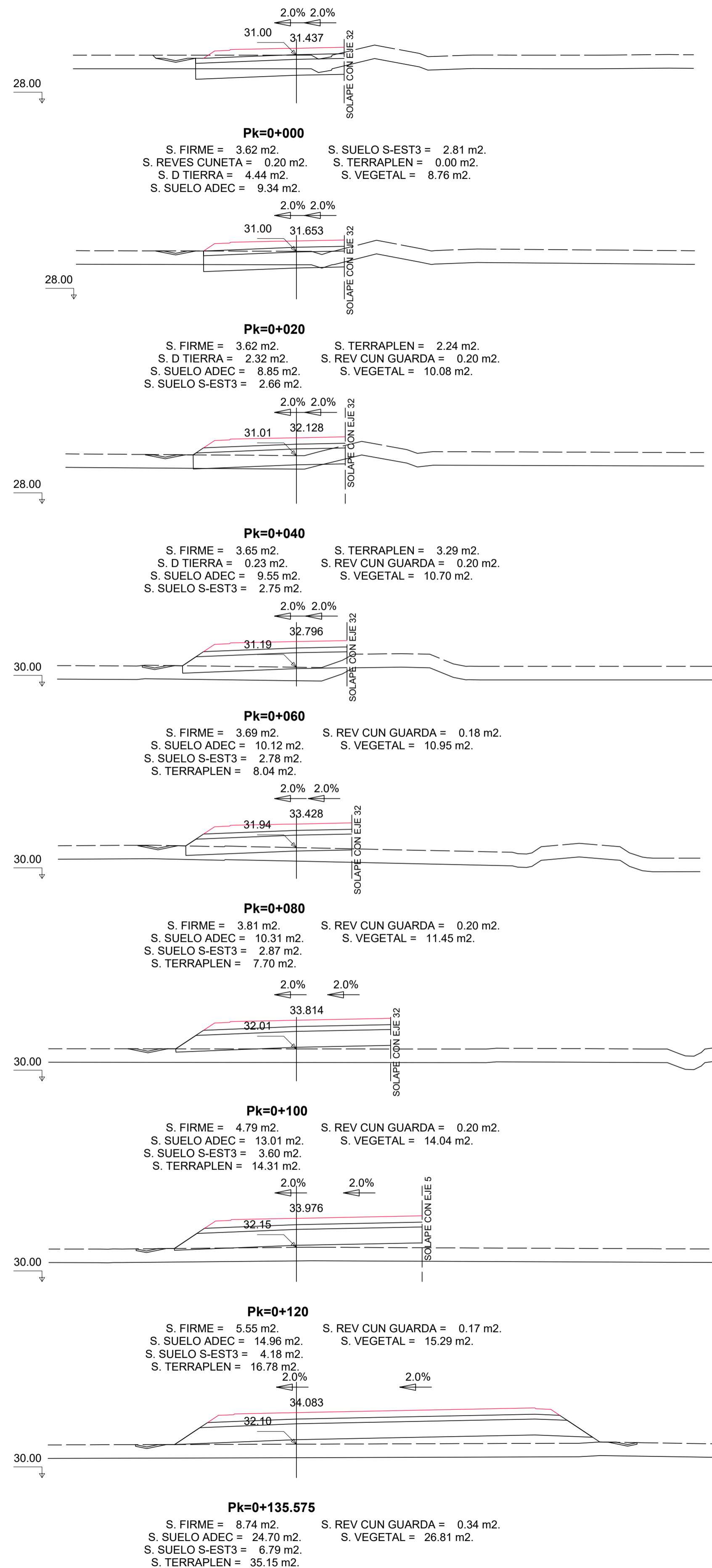

EJE 32

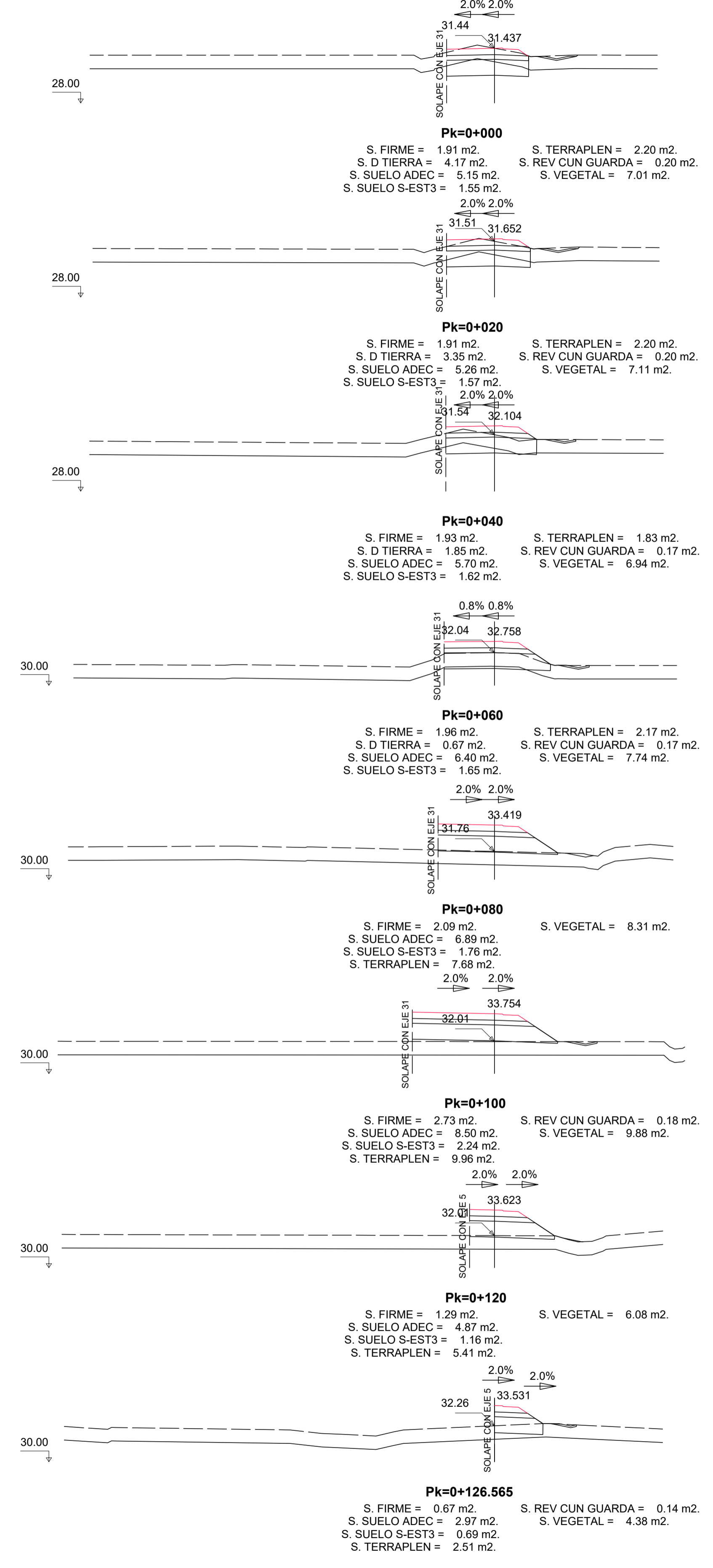

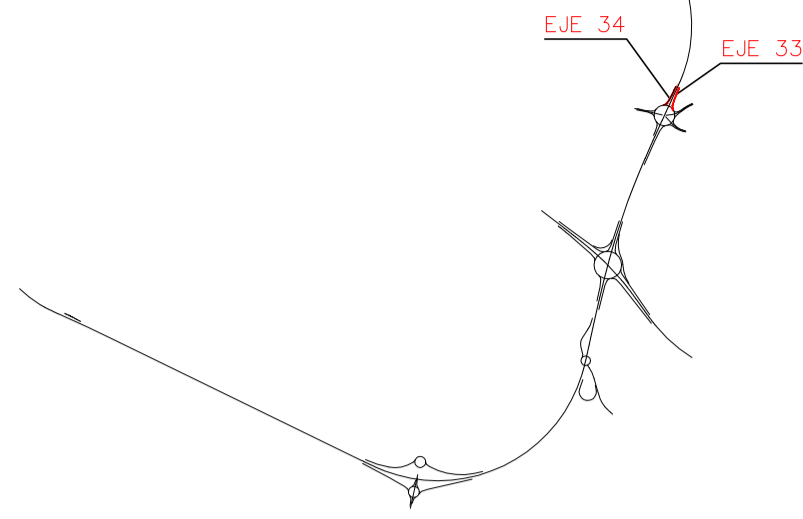

EJE 33

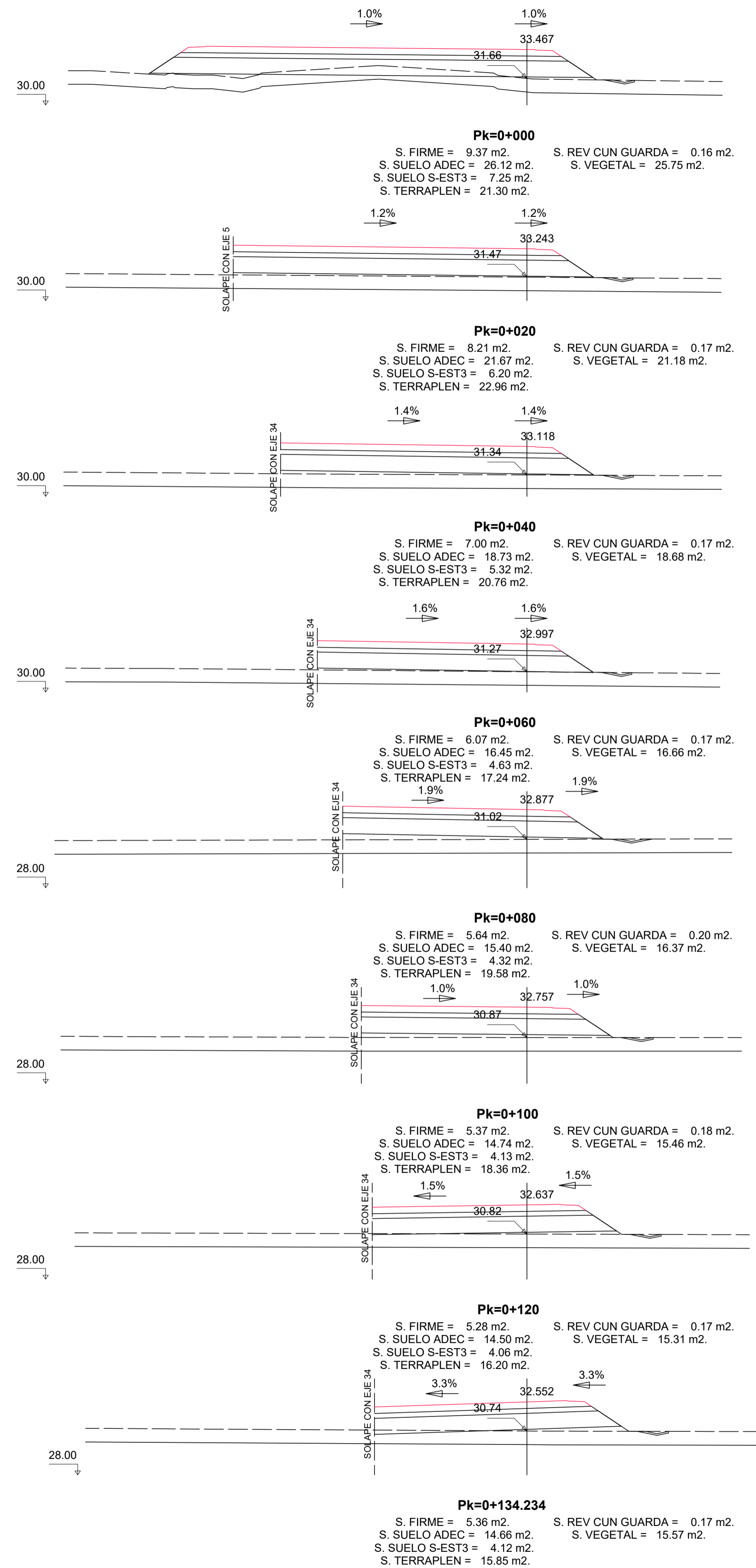

EJE 34

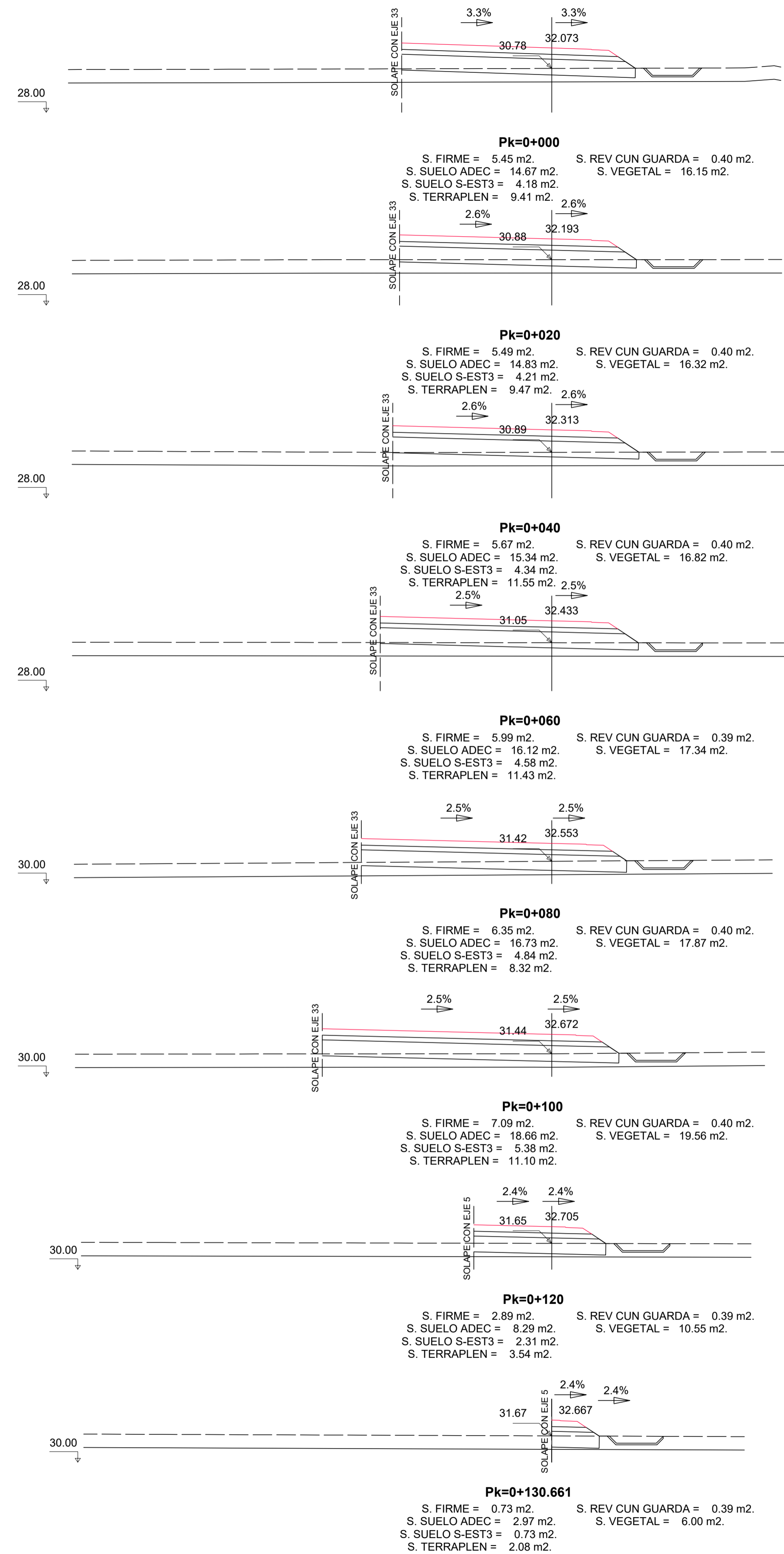

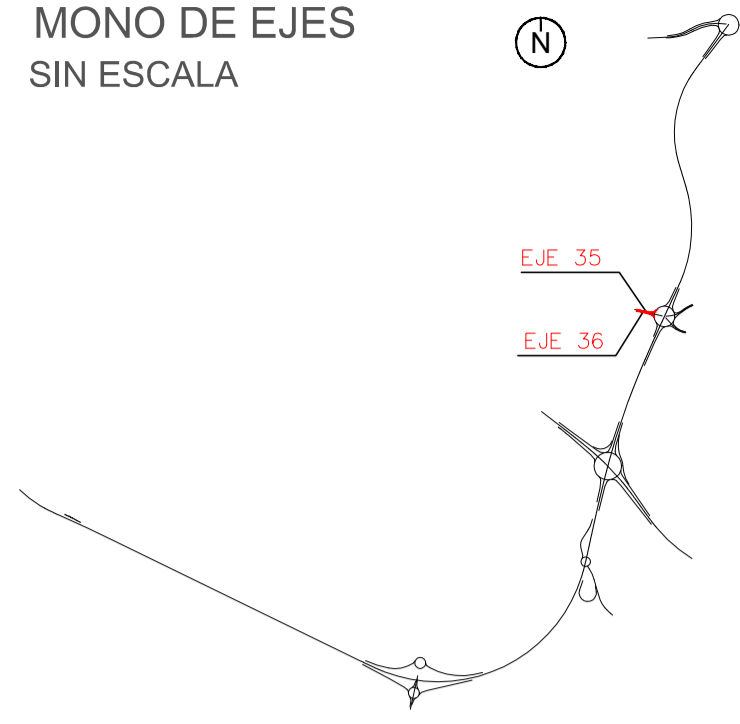

EJE 35

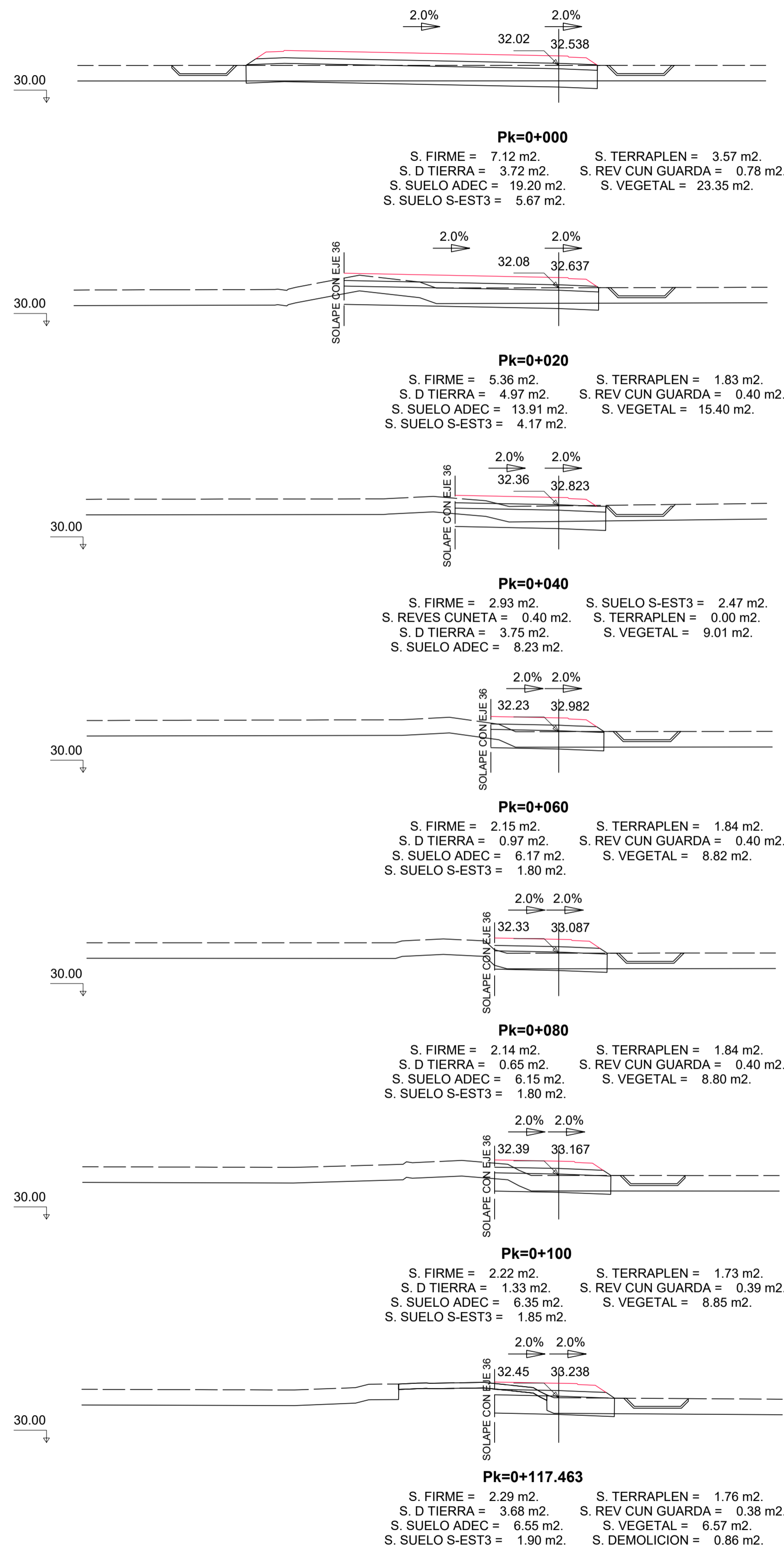

EJE 36

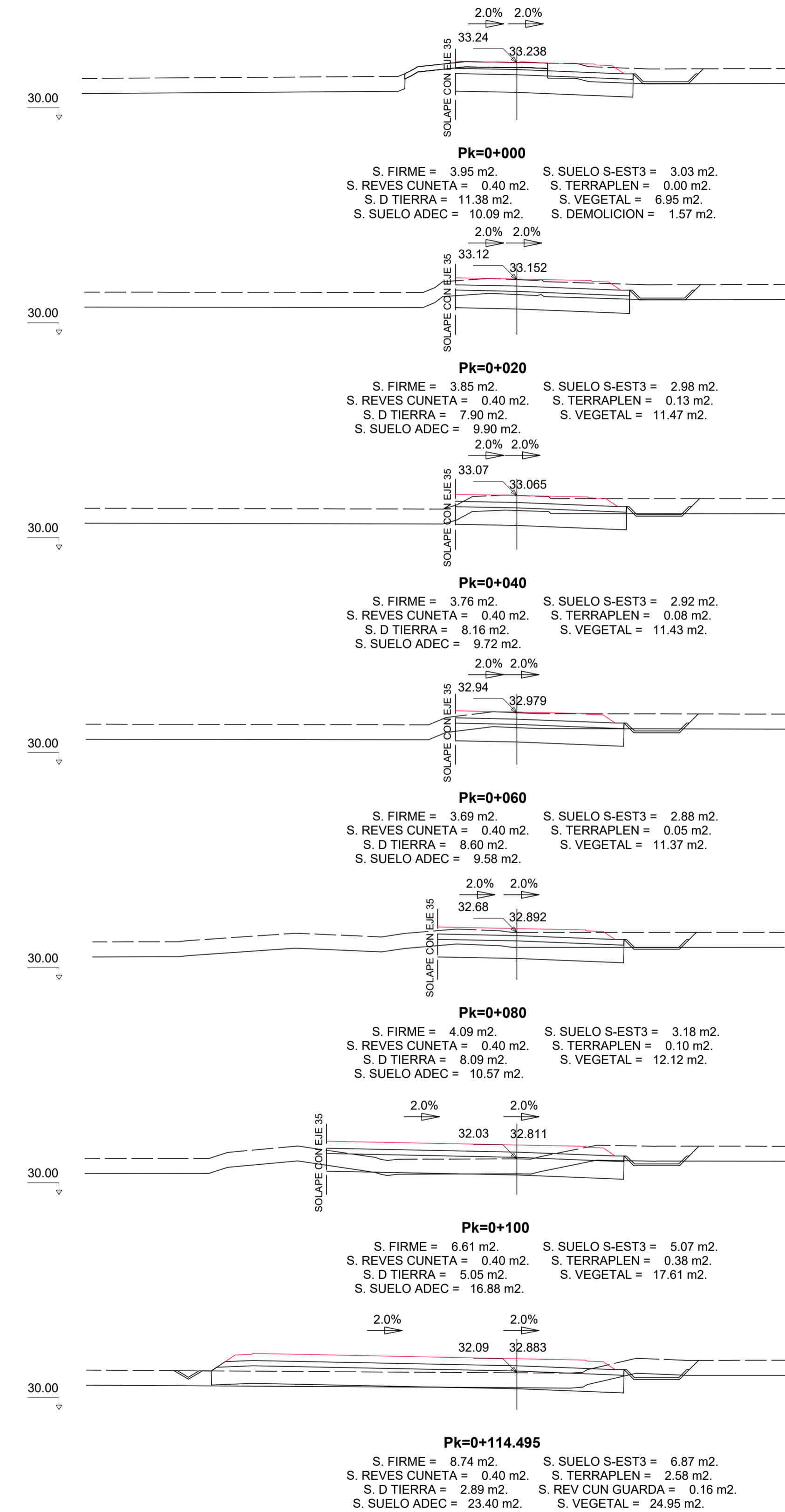

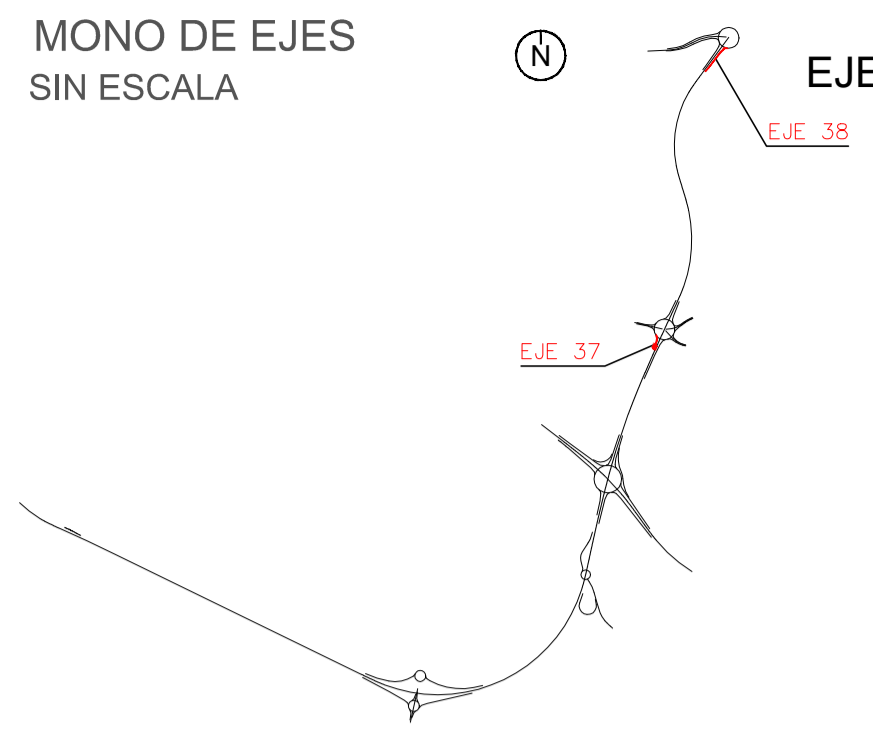

EJE 37

EJE 38

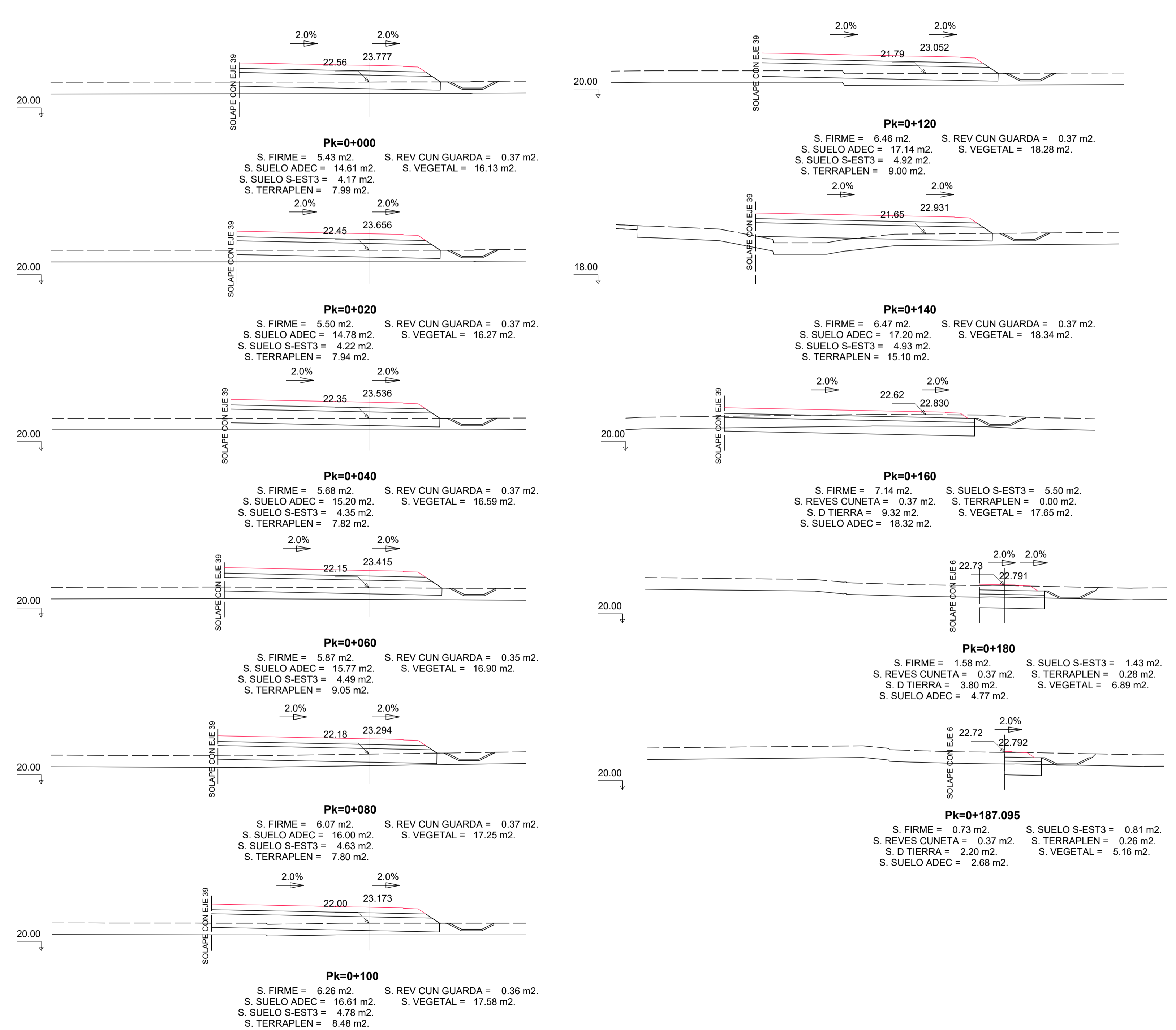
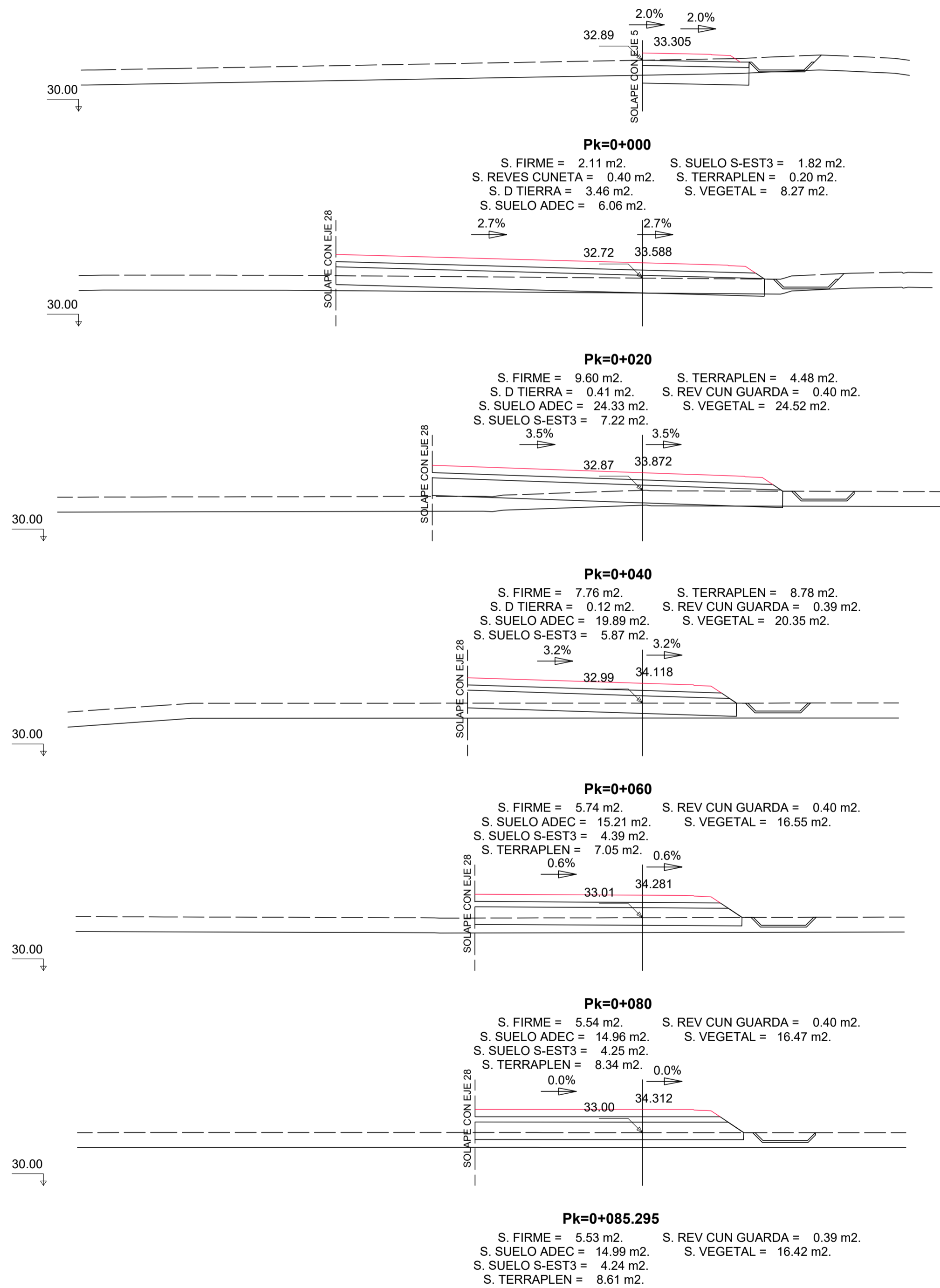

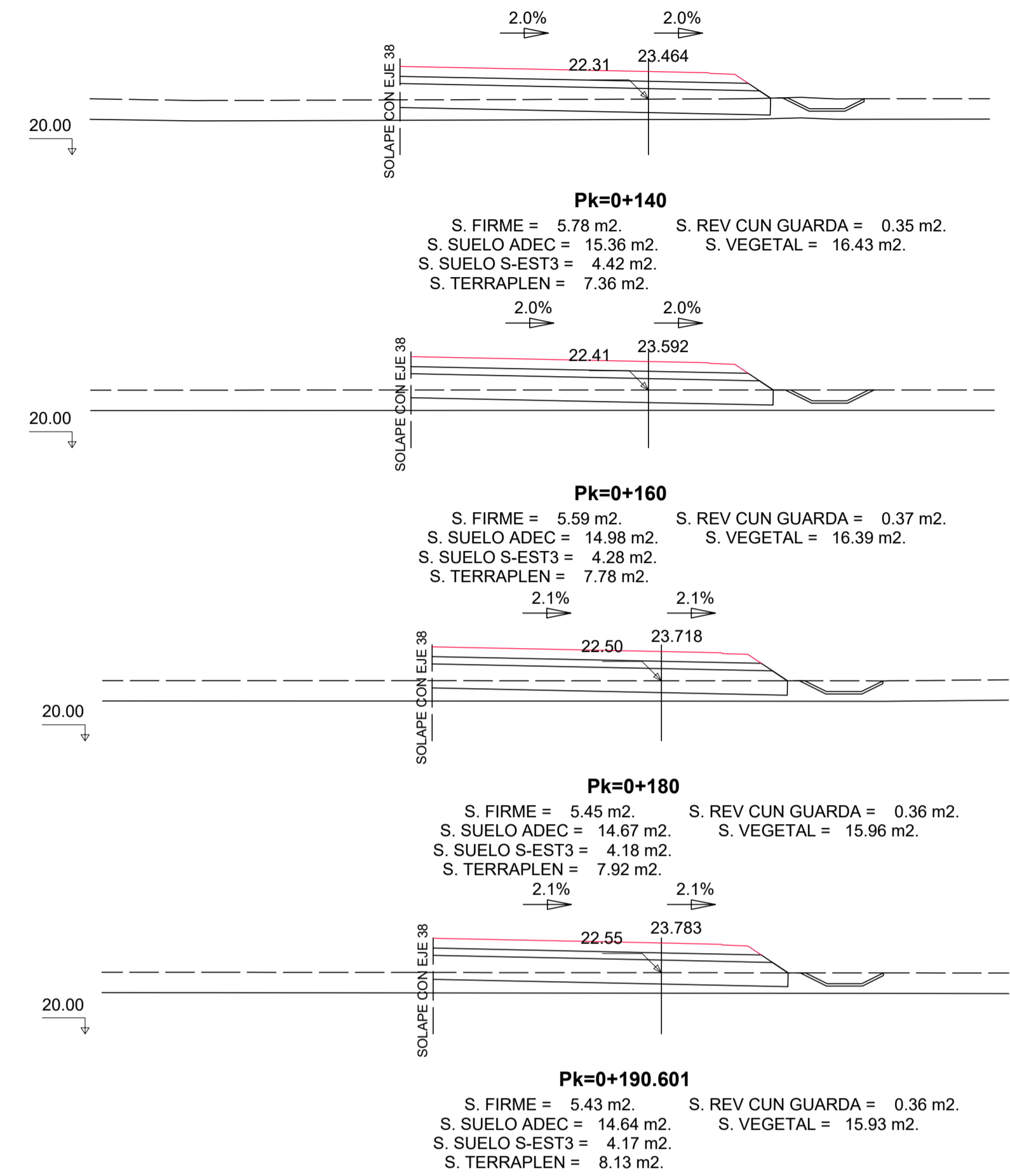
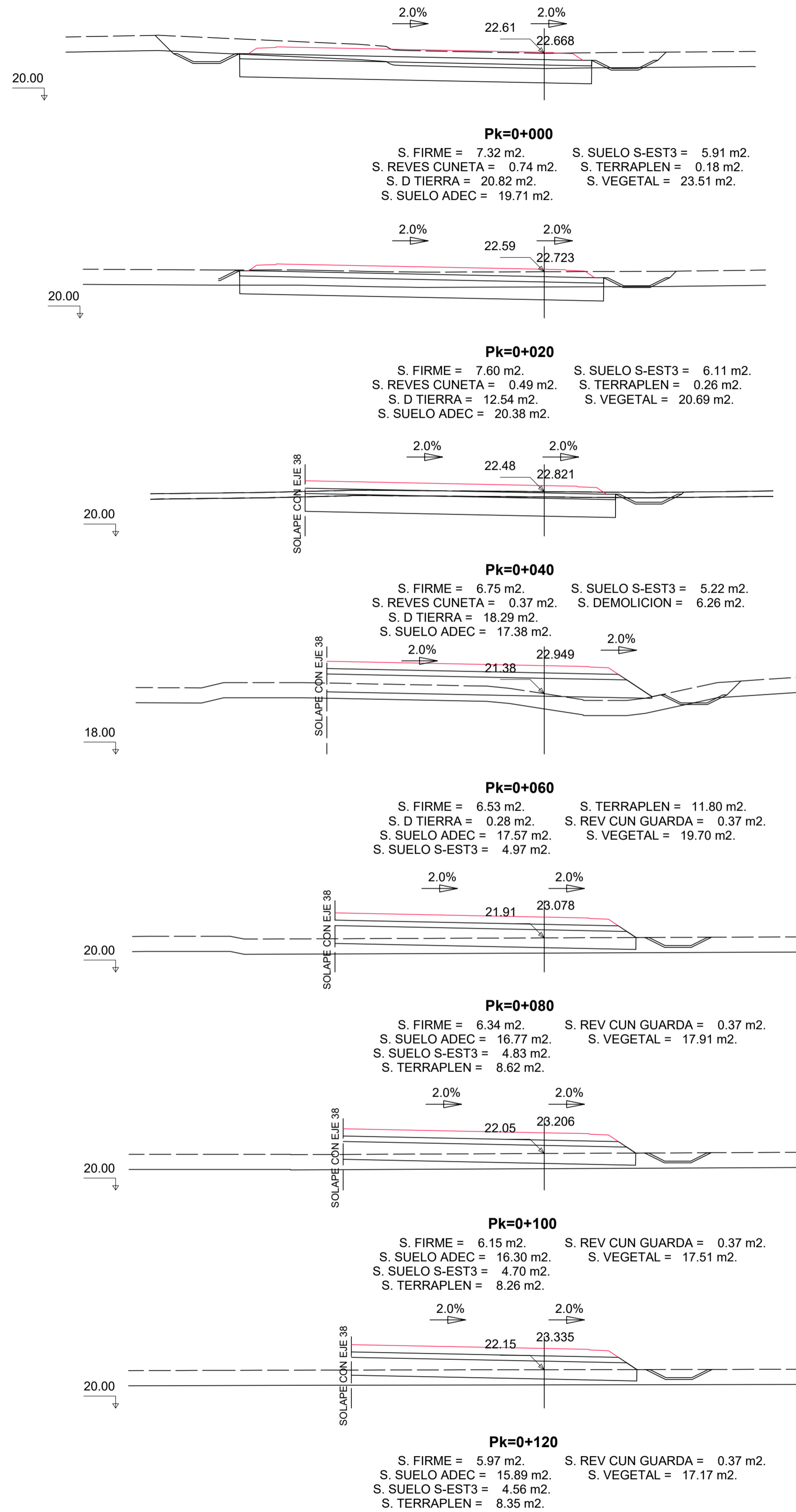
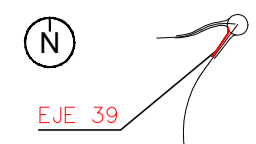

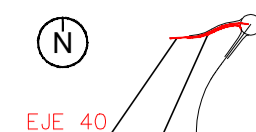

EJE 40

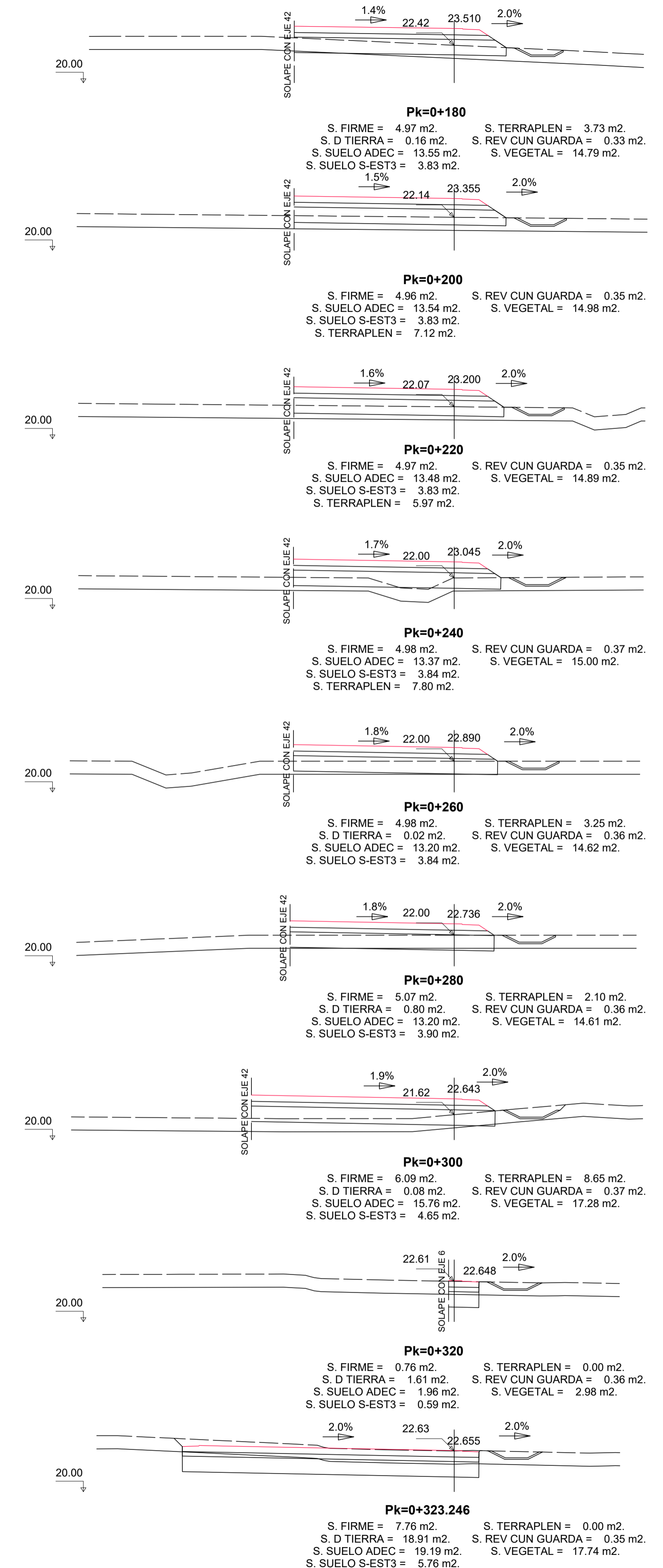
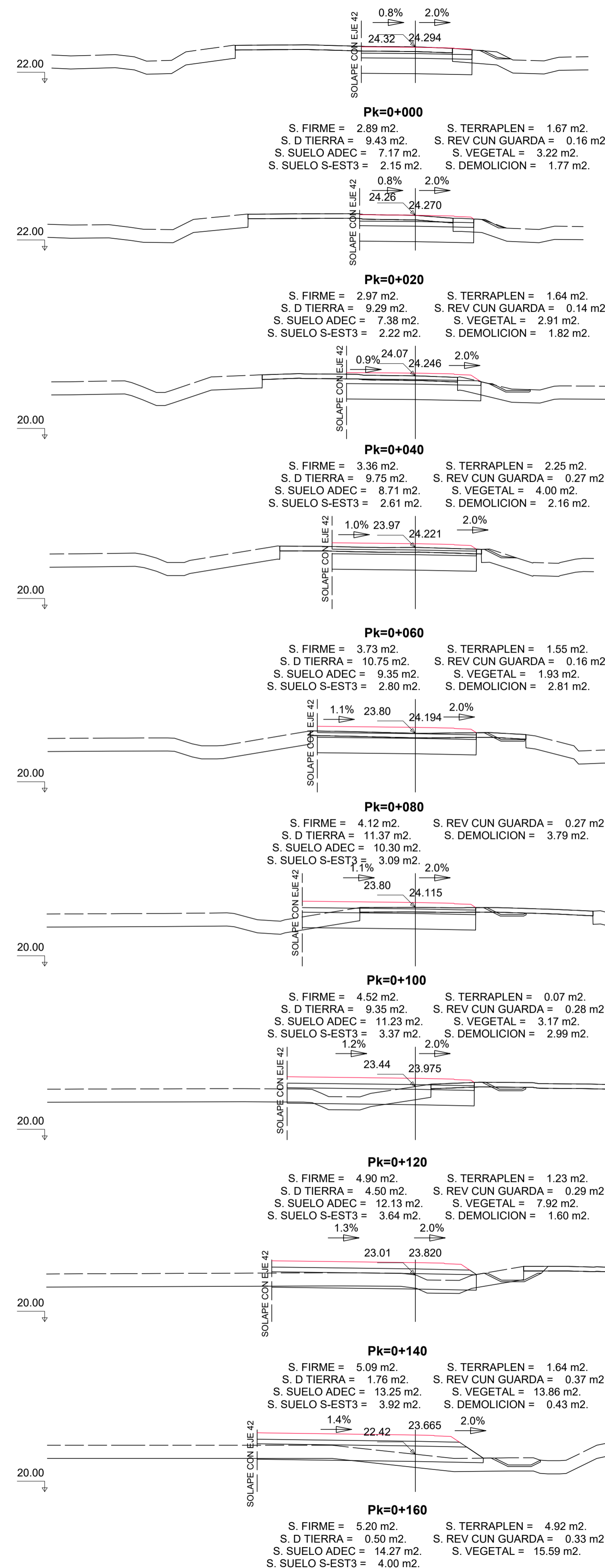
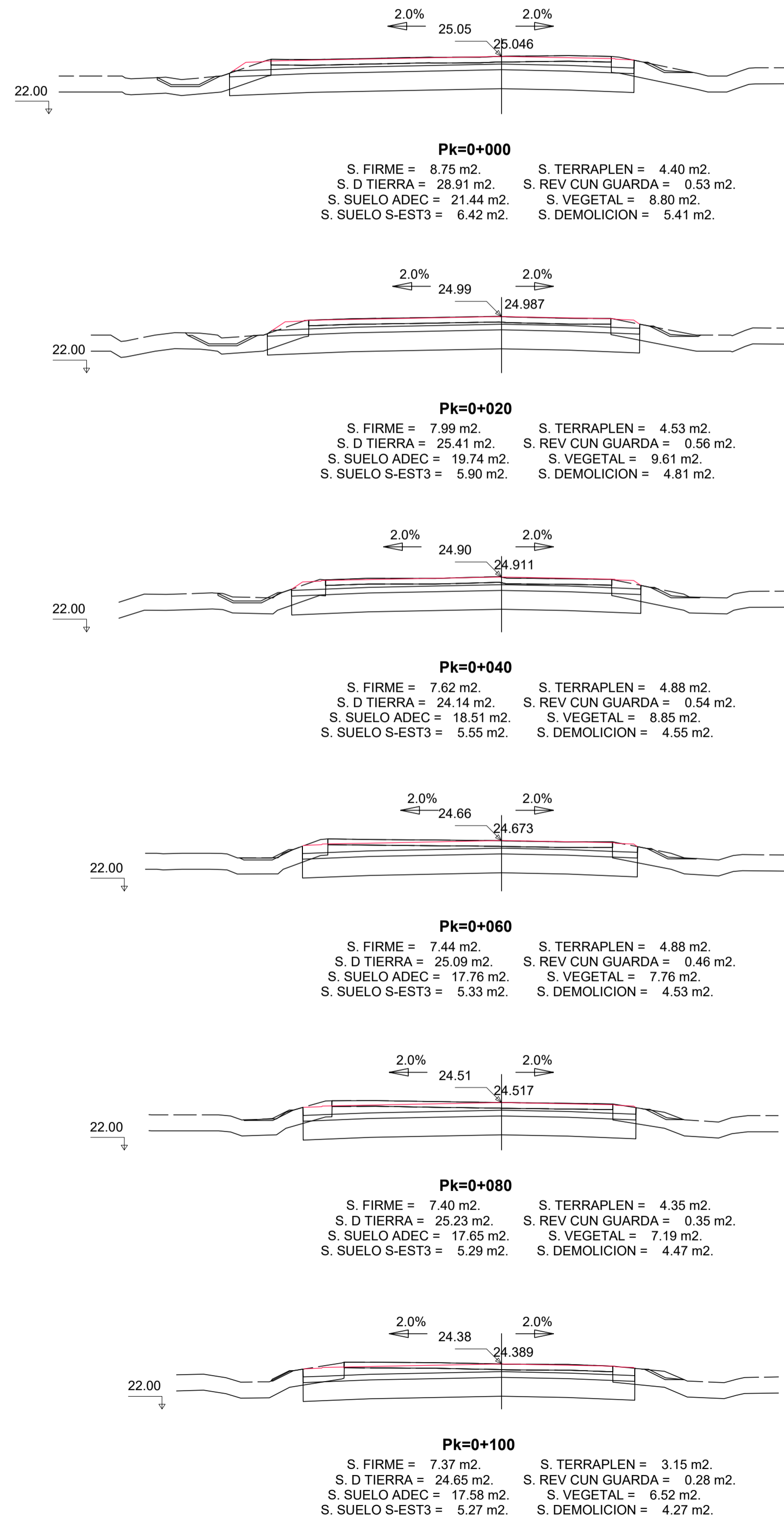

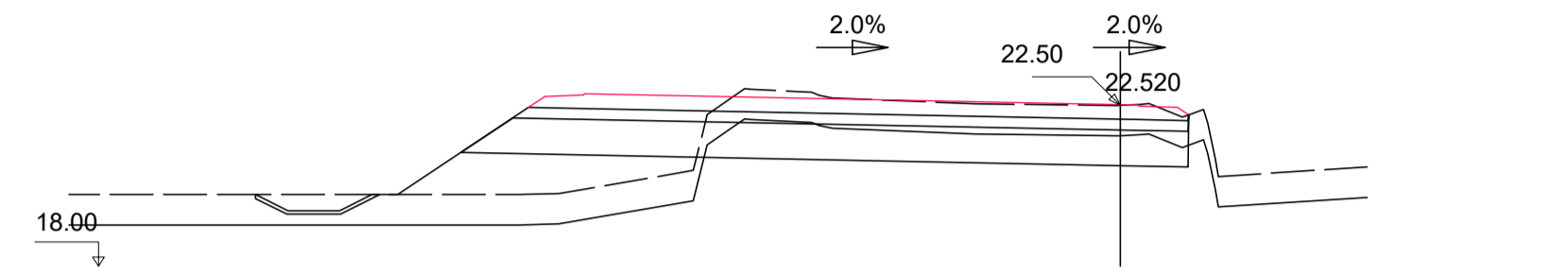

Pk=0+000
 S. FIRME = 7.30 m² S. TERRAPLEN = 16.12 m²
 S. D TIERRA = 11.47 m² S. REV CUN GUARDA = 0.36 m²
 S. SUELO ADEC = 19.63 m² S. VEGETAL = 22.20 m²
 S. SUELO S-EST3 = 5.61 m²

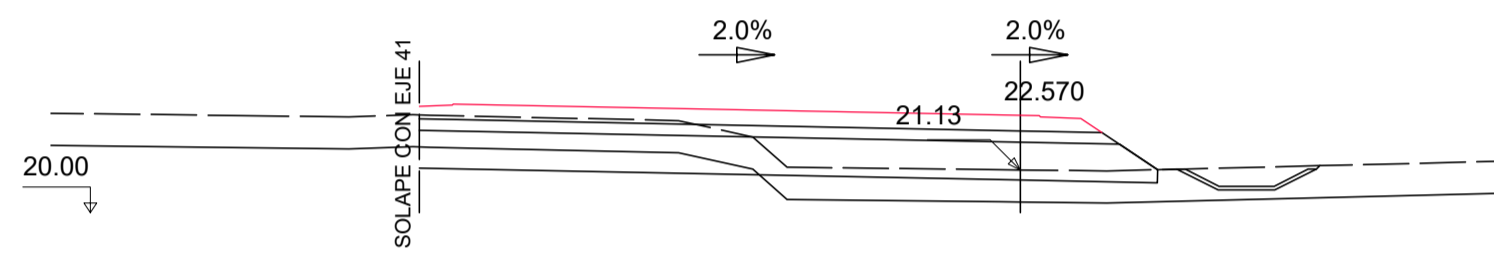

Pk=0+020
 S. FIRME = 7.18 m² S. TERRAPLEN = 8.06 m²
 S. D TIERRA = 4.45 m² S. REV CUN GUARDA = 0.37 m²
 S. SUELO ADEC = 19.20 m² S. VEGETAL = 20.25 m²
 S. SUELO S-EST3 = 5.49 m²

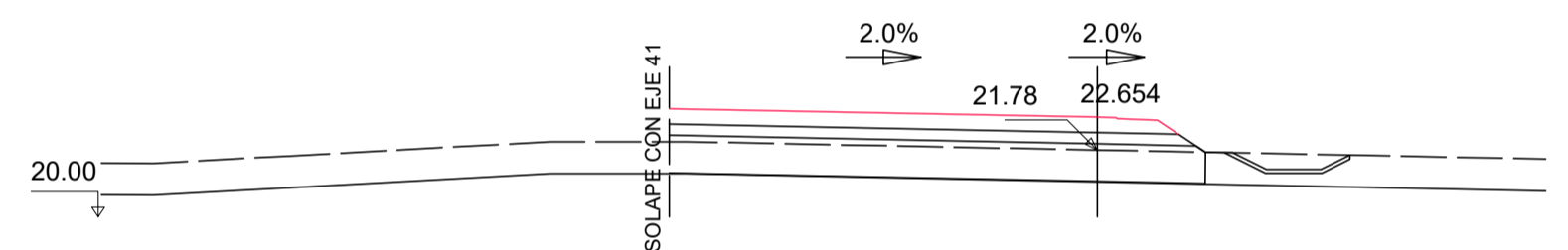

Pk=0+040
 S. FIRME = 5.39 m² S. REV CUN GUARDA = 0.34 m²
 S. SUELO ADEC = 14.25 m² S. VEGETAL = 15.40 m²
 S. SUELO S-EST3 = 4.14 m² S. TERRAPLEN = 2.19 m²

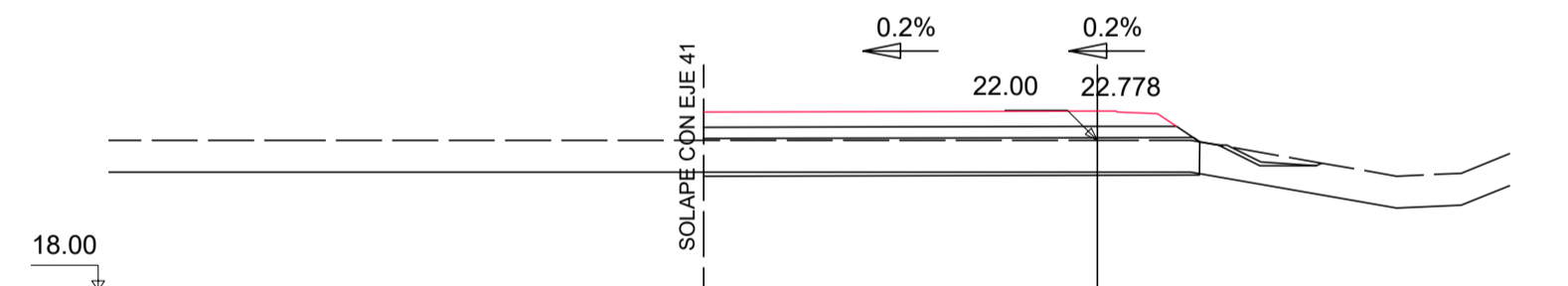

Pk=0+060
 S. FIRME = 4.98 m² S. TERRAPLEN = 2.22 m²
 S. D TIERRA = 1.19 m² S. REV CUN GUARDA = 0.19 m²
 S. SUELO ADEC = 13.19 m² S. VEGETAL = 13.98 m²
 S. SUELO S-EST3 = 3.84 m²

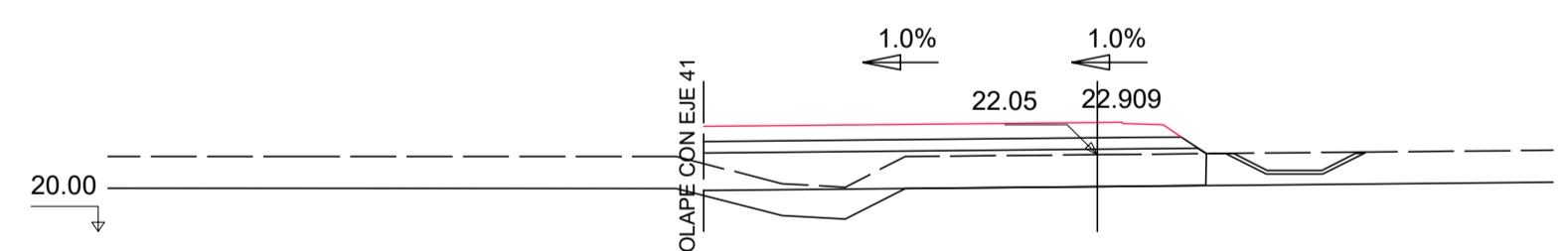

Pk=0+080
 S. FIRME = 5.03 m² S. TERRAPLEN = 4.87 m²
 S. D TIERRA = 0.01 m² S. REV CUN GUARDA = 0.37 m²
 S. SUELO ADEC = 13.36 m² S. VEGETAL = 14.97 m²
 S. SUELO S-EST3 = 3.88 m²

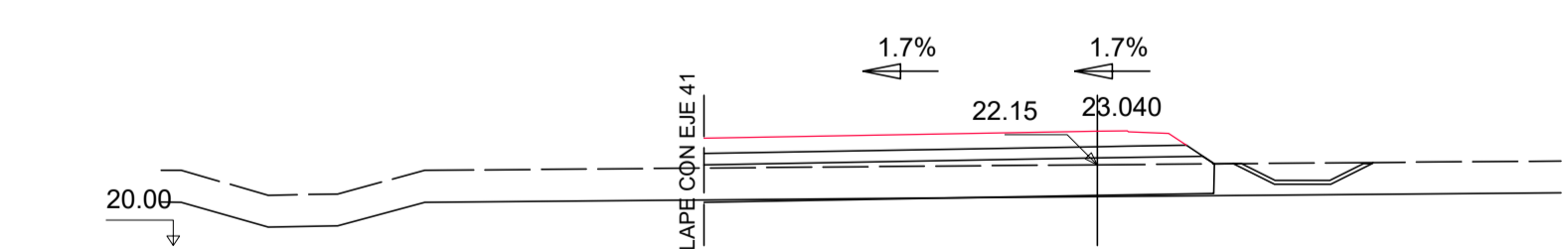

Pk=0+100
 S. FIRME = 5.08 m² S. TERRAPLEN = 2.31 m²
 S. D TIERRA = 0.22 m² S. REV CUN GUARDA = 0.37 m²
 S. SUELO ADEC = 13.55 m² S. VEGETAL = 15.15 m²
 S. SUELO S-EST3 = 3.92 m²

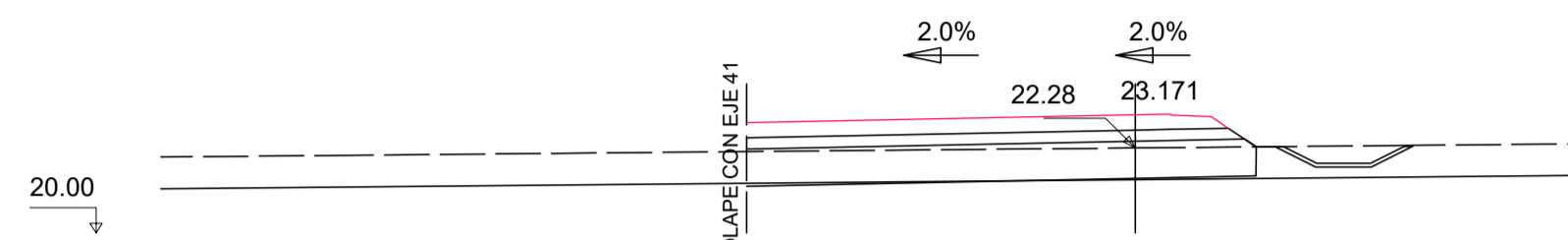

Pk=0+120
 S. FIRME = 5.14 m² S. TERRAPLEN = 2.31 m²
 S. D TIERRA = 0.31 m² S. REV CUN GUARDA = 0.37 m²
 S. SUELO ADEC = 13.70 m² S. VEGETAL = 15.27 m²
 S. SUELO S-EST3 = 3.96 m²

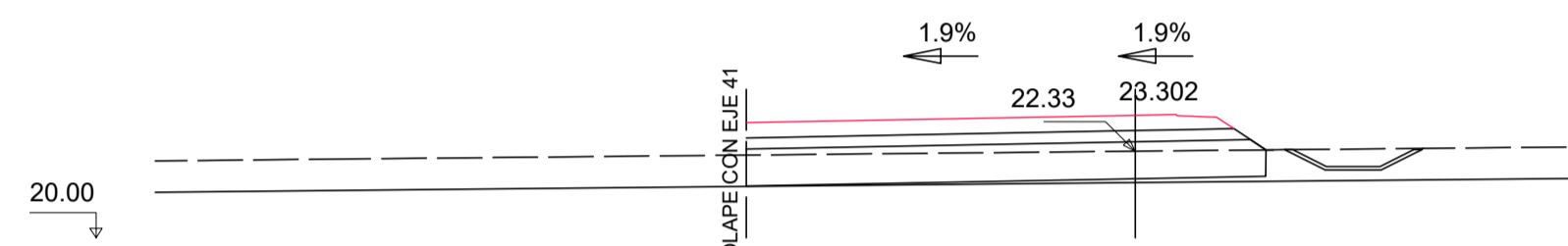

Pk=0+140
 S. FIRME = 5.20 m² S. REV CUN GUARDA = 0.37 m²
 S. SUELO ADEC = 13.93 m² S. VEGETAL = 15.50 m²
 S. SUELO S-EST3 = 4.01 m² S. TERRAPLEN = 3.17 m²

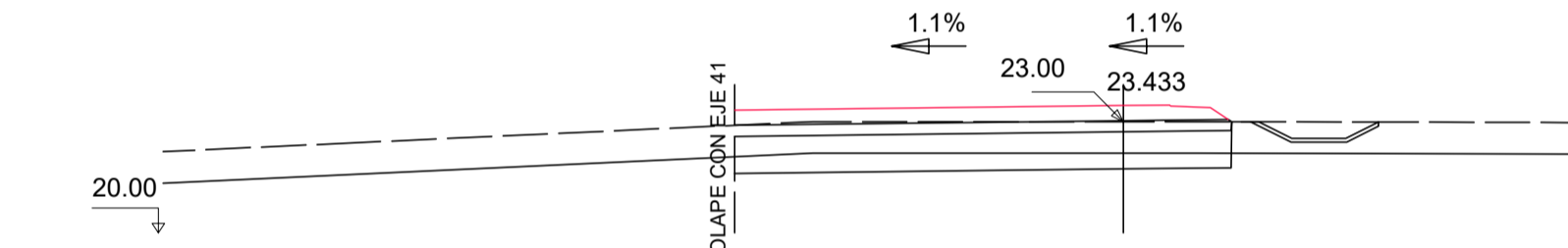

Pk=0+160
 S. FIRME = 5.28 m² S. TERRAPLEN = 1.97 m²
 S. D TIERRA = 6.19 m² S. REV CUN GUARDA = 0.36 m²
 S. SUELO ADEC = 13.39 m² S. VEGETAL = 14.75 m²
 S. SUELO S-EST3 = 4.01 m²

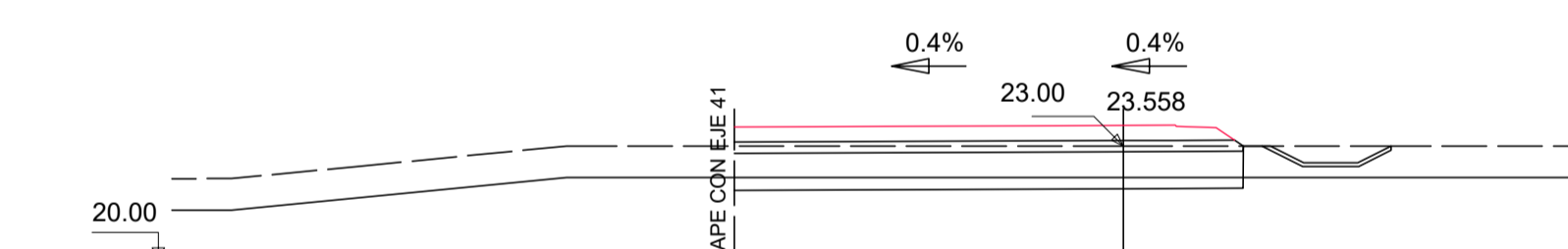

Pk=0+180
 S. FIRME = 5.35 m² S. TERRAPLEN = 1.97 m²
 S. D TIERRA = 4.33 m² S. REV CUN GUARDA = 0.36 m²
 S. SUELO ADEC = 13.71 m² S. VEGETAL = 15.04 m²
 S. SUELO S-EST3 = 4.09 m²

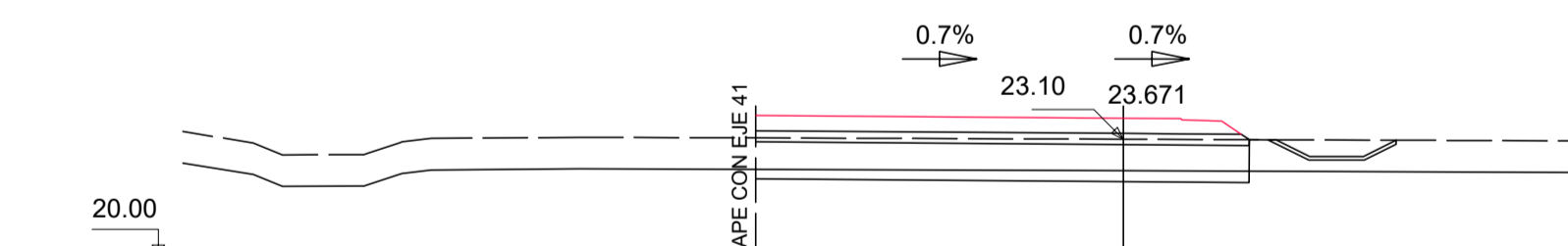

Pk=0+200
 S. FIRME = 5.19 m² S. TERRAPLEN = 1.97 m²
 S. D TIERRA = 3.73 m² S. REV CUN GUARDA = 0.36 m²
 S. SUELO ADEC = 13.29 m² S. VEGETAL = 14.66 m²
 S. SUELO S-EST3 = 3.97 m²

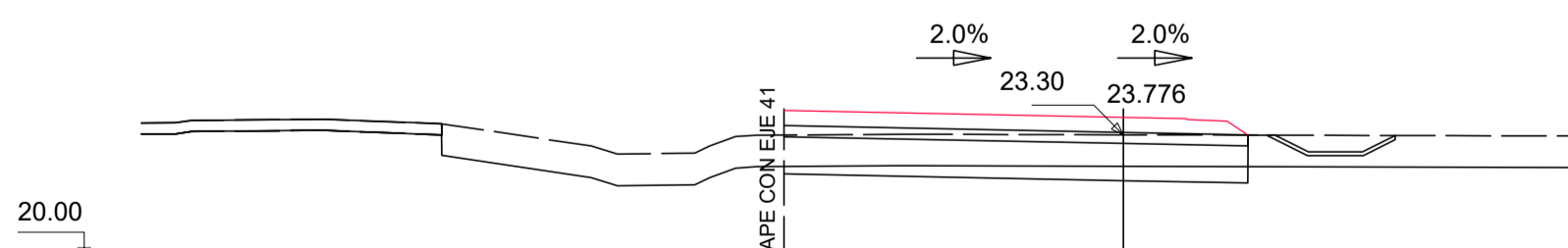

Pk=0+220
 S. FIRME = 4.95 m² S. TERRAPLEN = 1.97 m²
 S. D TIERRA = 4.15 m² S. REV CUN GUARDA = 0.36 m²
 S. SUELO ADEC = 12.50 m² S. VEGETAL = 14.00 m²
 S. SUELO S-EST3 = 3.75 m²

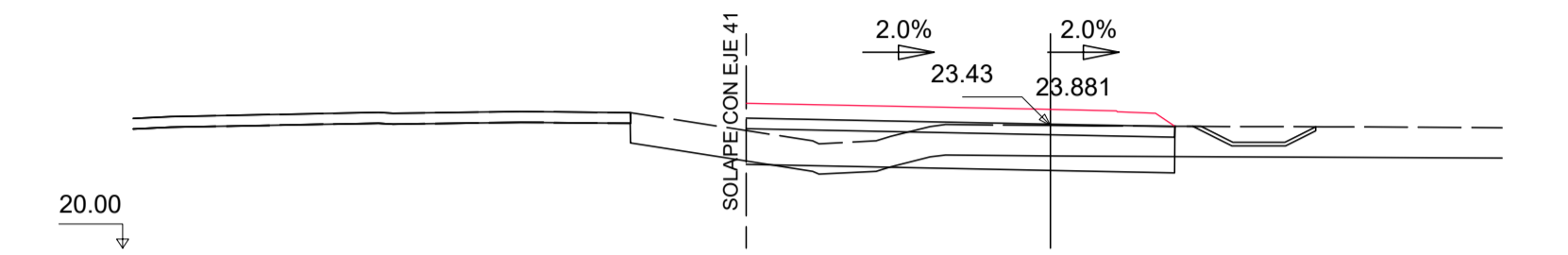

Pk=0+240
 S. FIRME = 4.76 m² S. TERRAPLEN = 2.39 m²
 S. D TIERRA = 3.04 m² S. REV CUN GUARDA = 0.36 m²
 S. SUELO ADEC = 12.01 m² S. VEGETAL = 13.57 m²
 S. SUELO S-EST3 = 3.60 m²

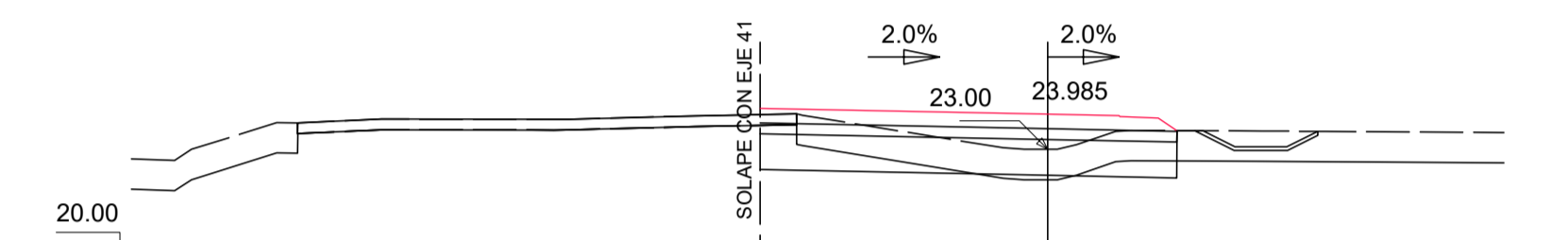

Pk=0+260
 S. FIRME = 4.63 m² S. TERRAPLEN = 2.23 m²
 S. D TIERRA = 4.10 m² S. REV CUN GUARDA = 0.36 m²
 S. SUELO ADEC = 11.68 m² S. VEGETAL = 12.41 m²
 S. SUELO S-EST3 = 3.50 m² S. DEMOLICION = 0.31 m²

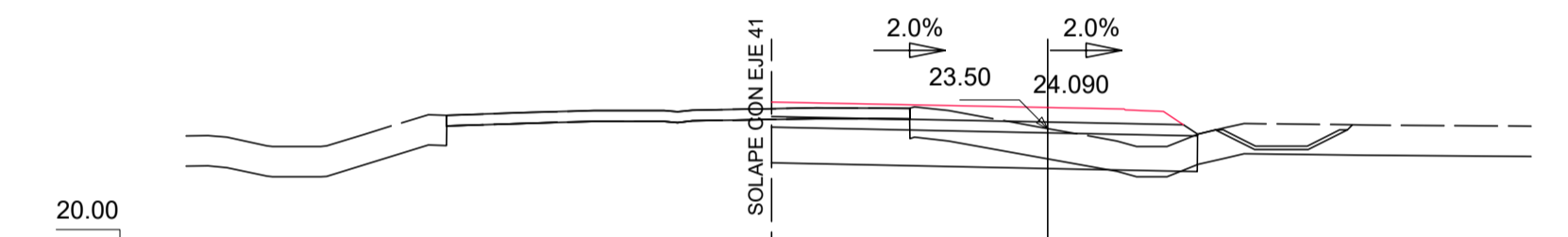

Pk=0+280
 S. FIRME = 4.56 m² S. TERRAPLEN = 1.95 m²
 S. D TIERRA = 7.40 m² S. REV CUN GUARDA = 0.37 m²
 S. SUELO ADEC = 11.93 m² S. VEGETAL = 10.54 m²
 S. SUELO S-EST3 = 3.53 m² S. DEMOLICION = 1.16 m²

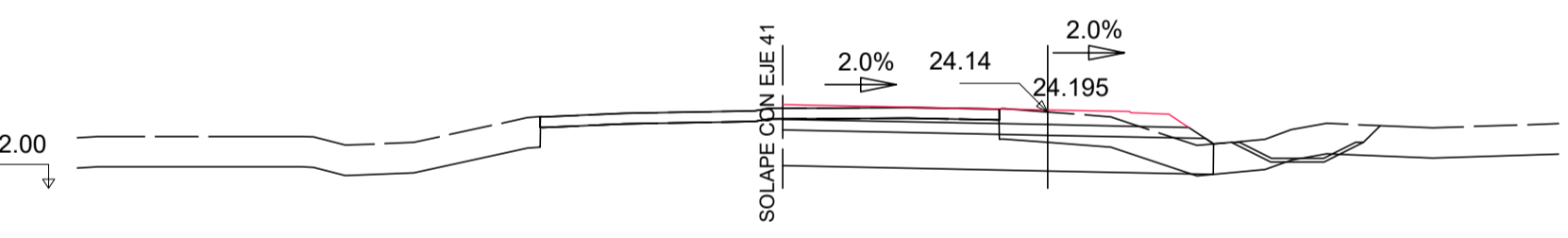

Pk=0+300
 S. FIRME = 4.49 m² S. TERRAPLEN = 1.46 m²
 S. D TIERRA = 11.77 m² S. REV CUN GUARDA = 0.37 m²
 S. SUELO ADEC = 12.05 m² S. VEGETAL = 9.07 m²
 S. SUELO S-EST3 = 3.48 m² S. DEMOLICION = 1.82 m²

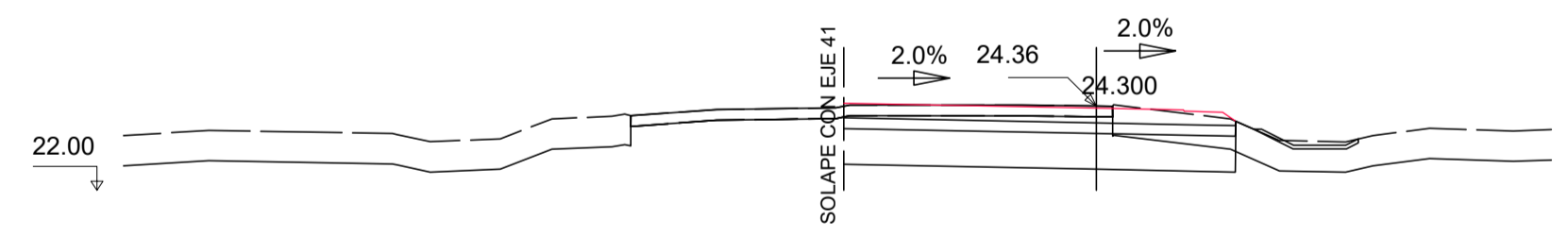

Pk=0+320
 S. FIRME = 4.40 m² S. TERRAPLEN = 2.49 m²
 S. D TIERRA = 13.47 m² S. REV CUN GUARDA = 0.30 m²
 S. SUELO ADEC = 10.98 m² S. VEGETAL = 5.85 m²
 S. SUELO S-EST3 = 3.29 m² S. DEMOLICION = 2.26 m²

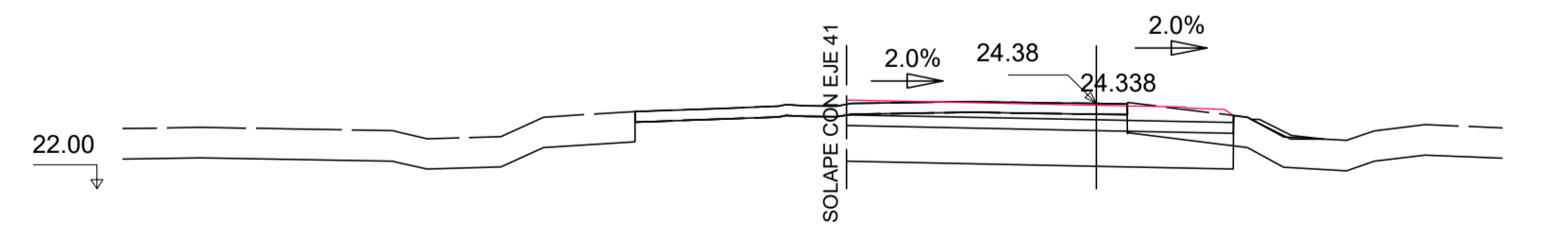

Pk=0+327.266
 S. FIRME = 4.37 m² S. TERRAPLEN = 2.14 m²
 S. D TIERRA = 13.53 m² S. REV CUN GUARDA = 0.16 m²
 S. SUELO ADEC = 10.85 m² S. VEGETAL = 4.68 m²
 S. SUELO S-EST3 = 3.25 m² S. DEMOLICION = 2.36 m²

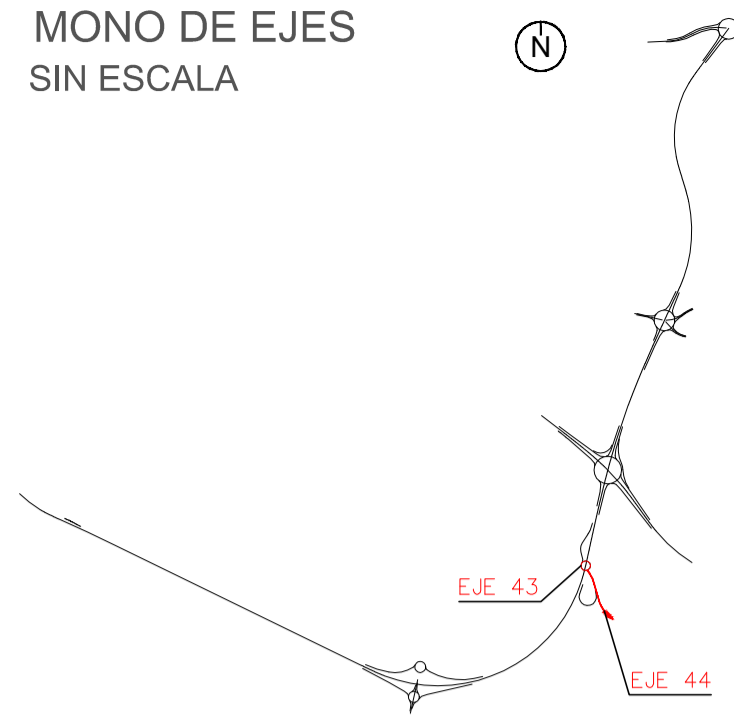

EJE 43

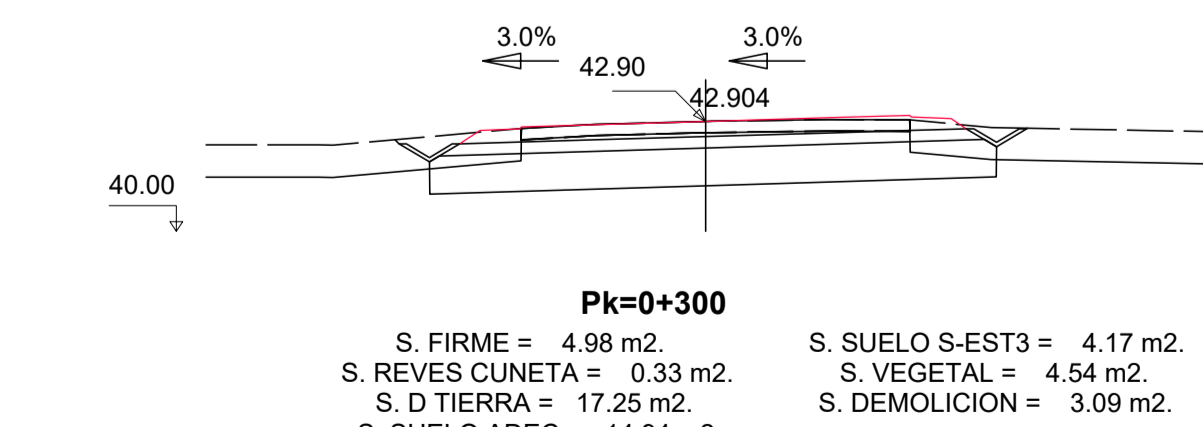
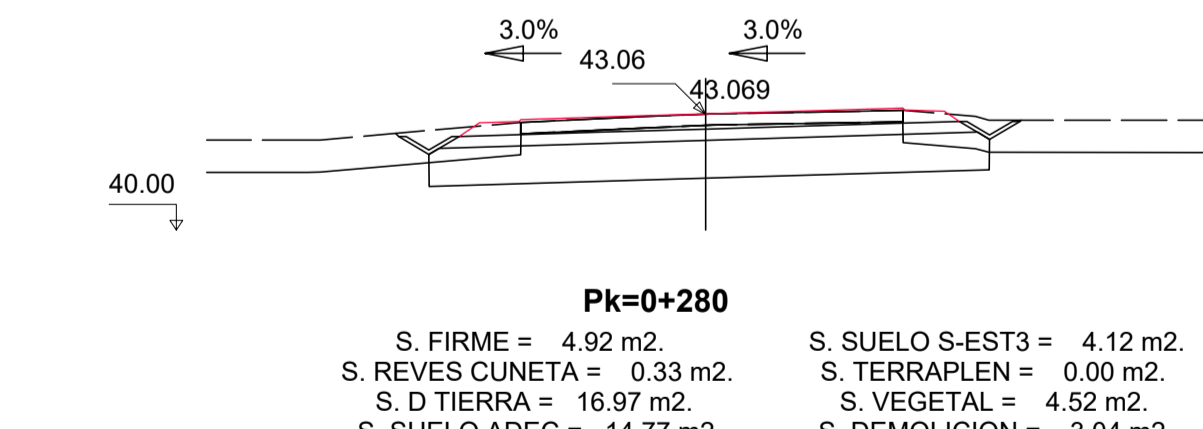
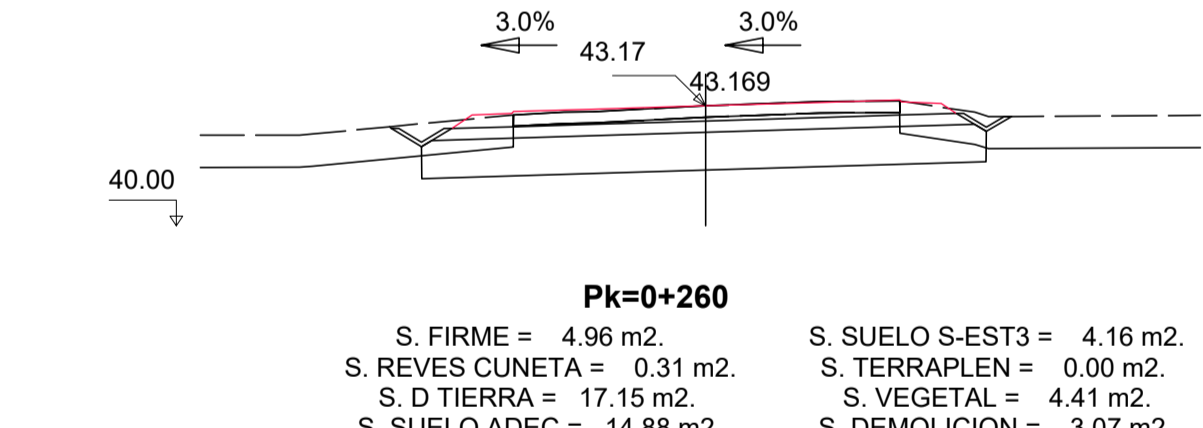
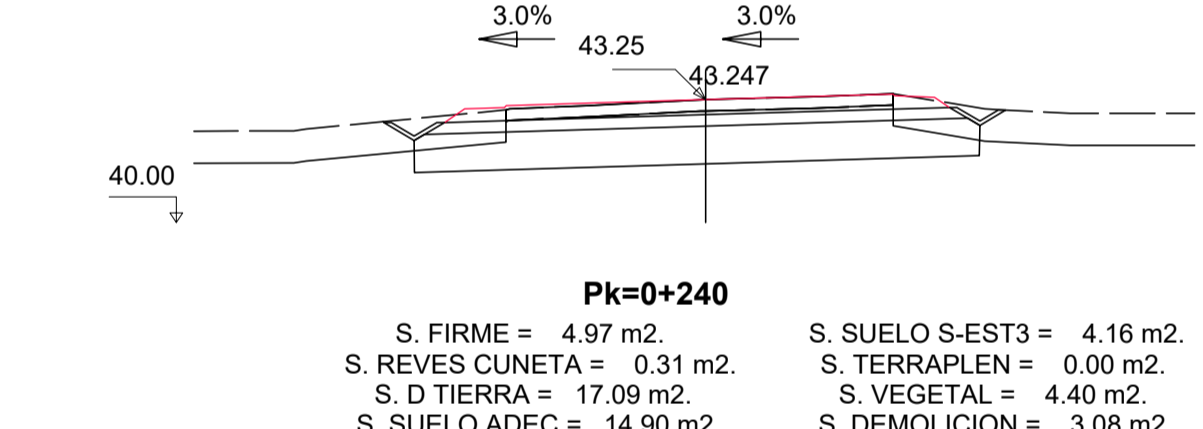
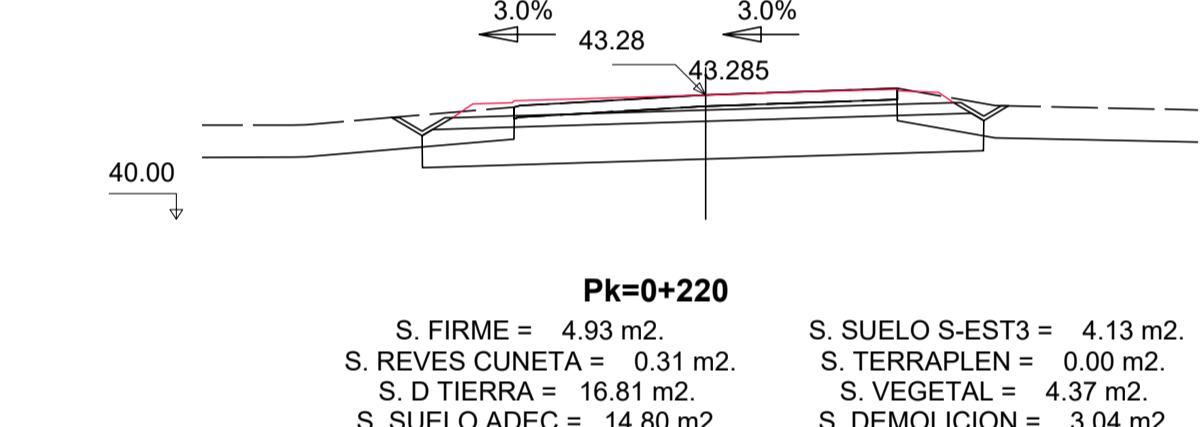
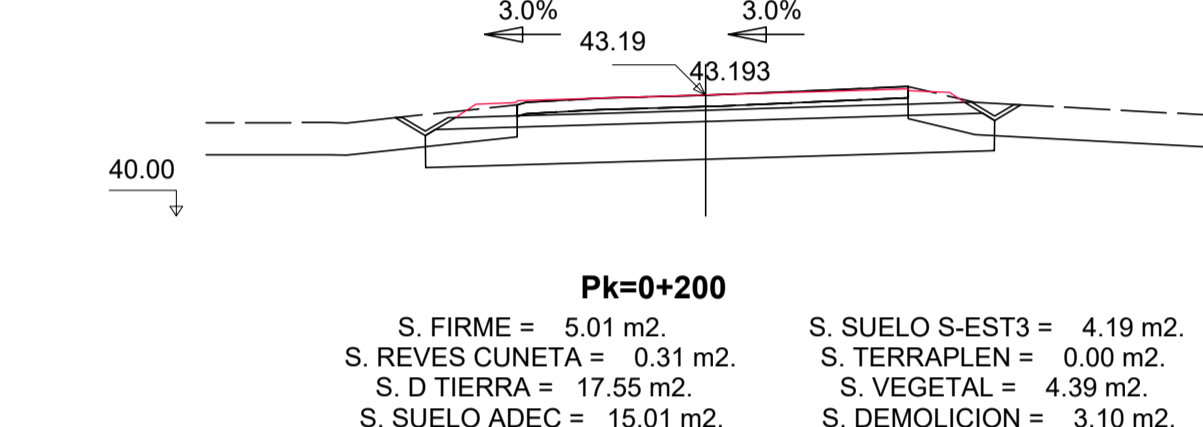
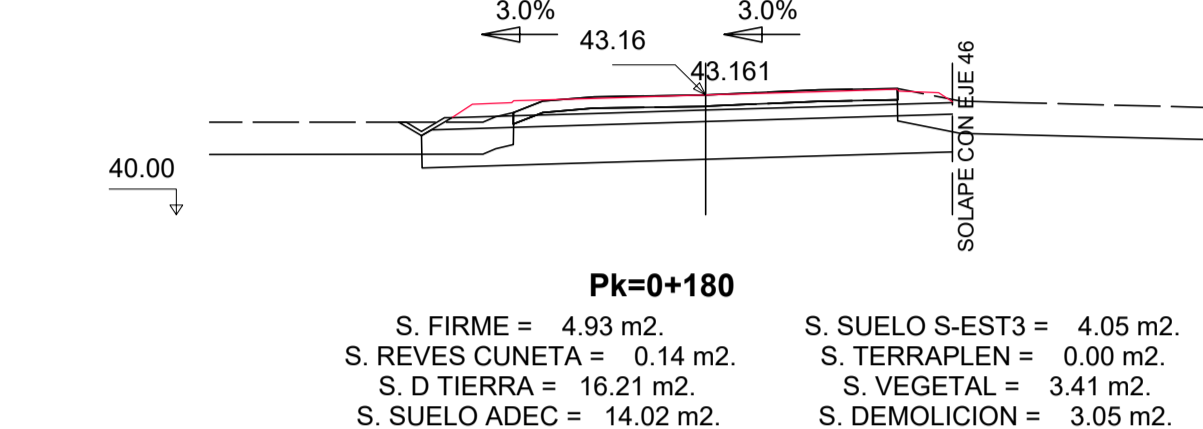
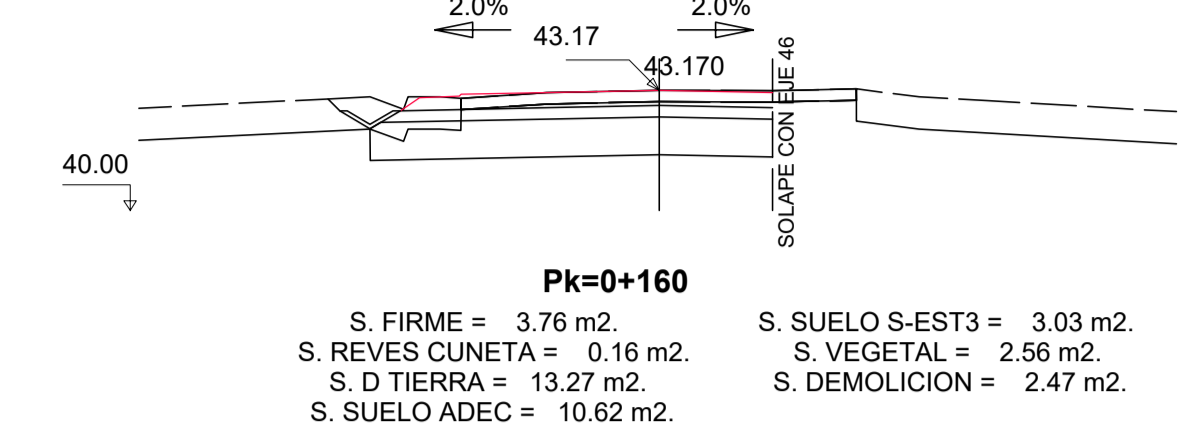
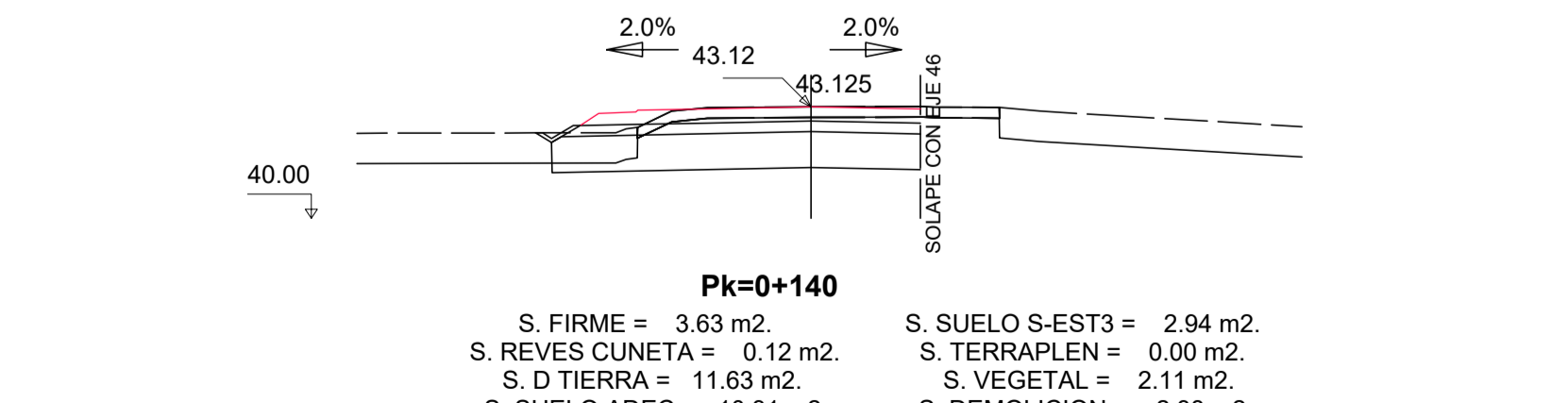
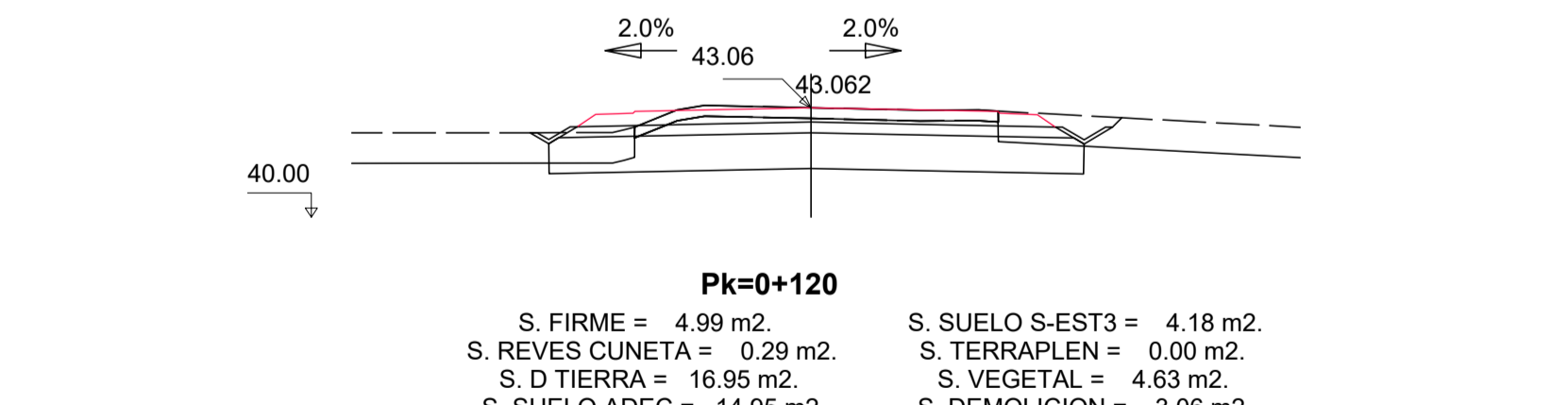
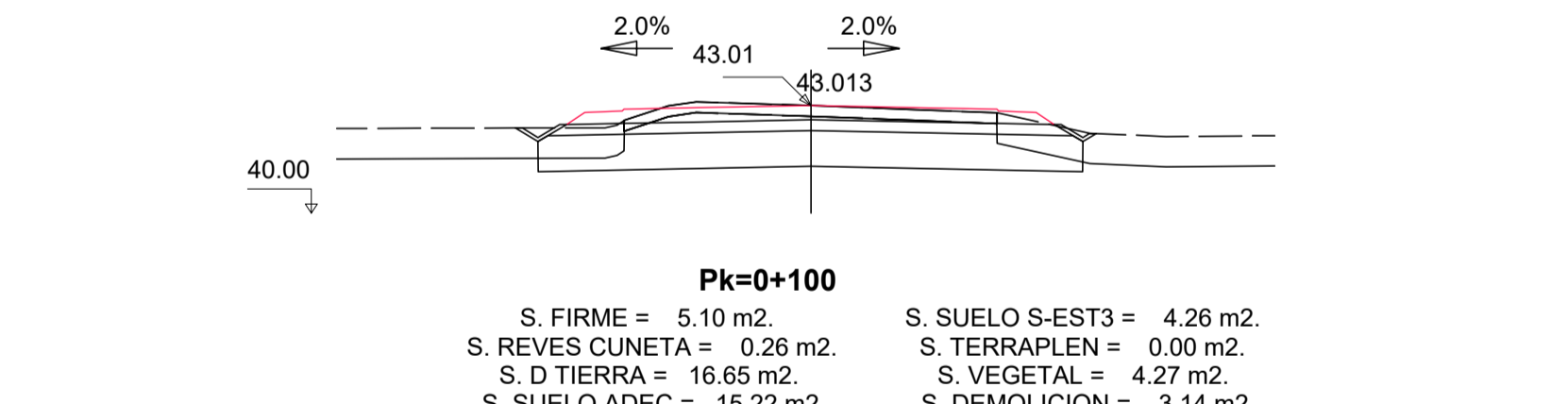
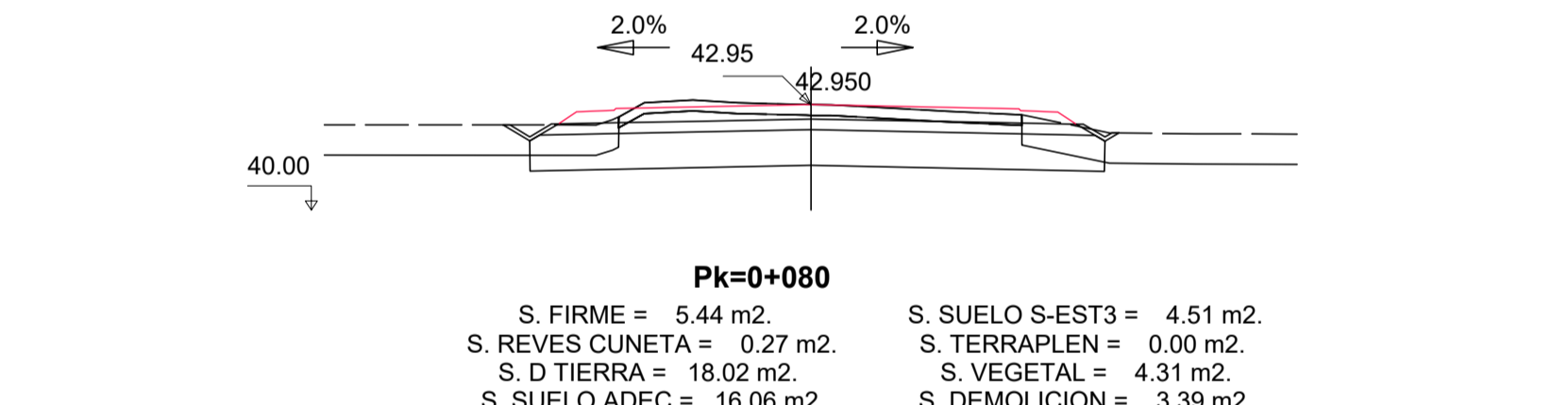
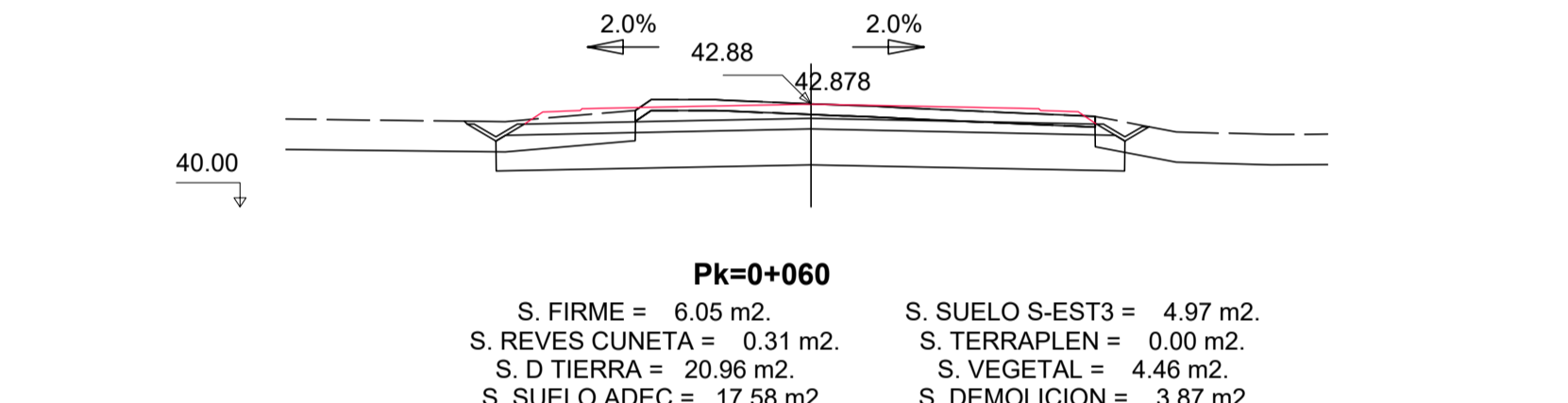
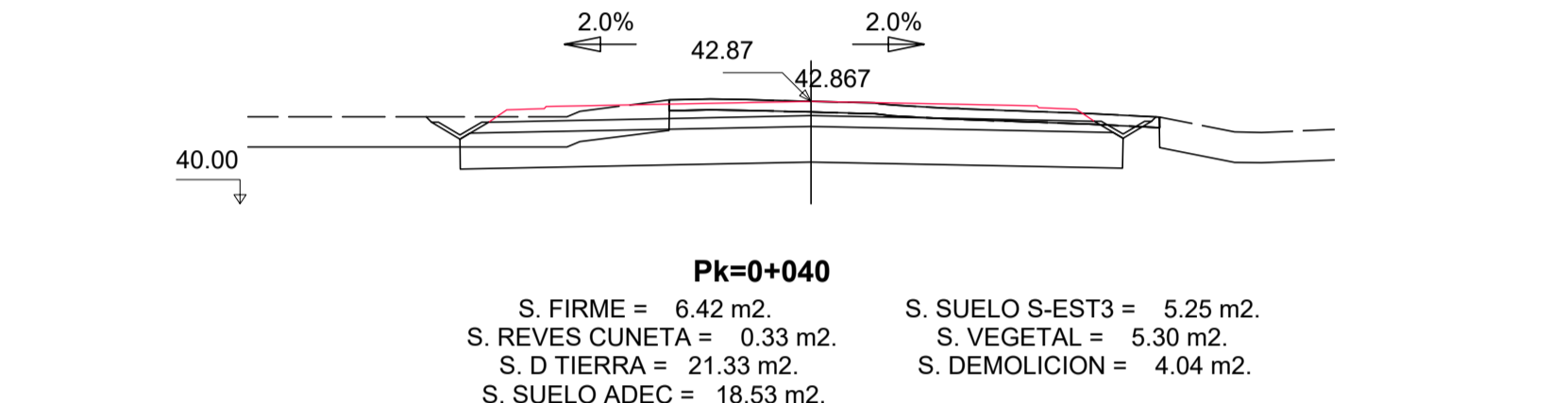
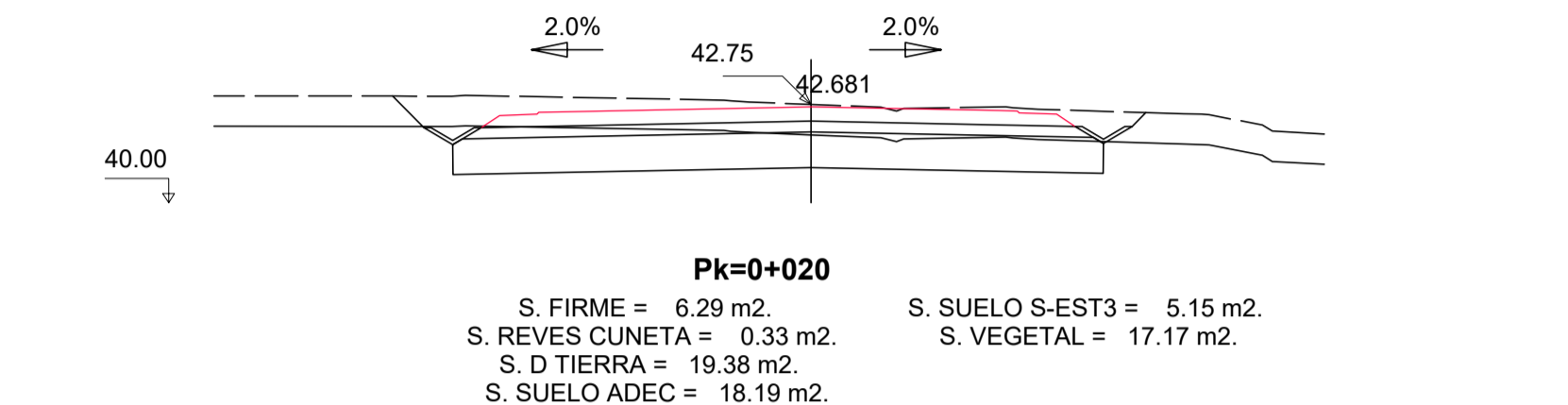
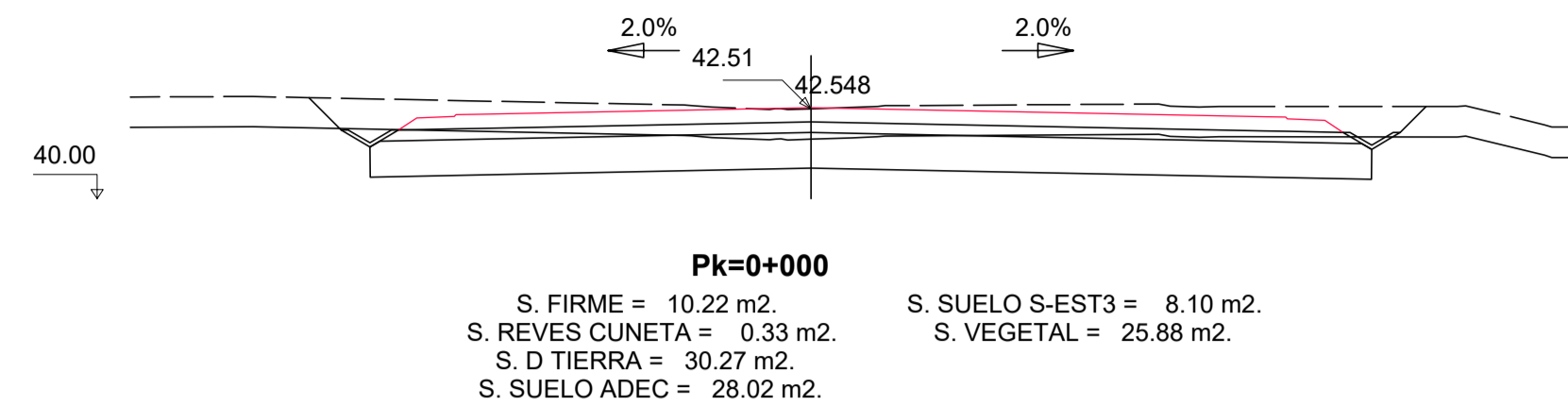
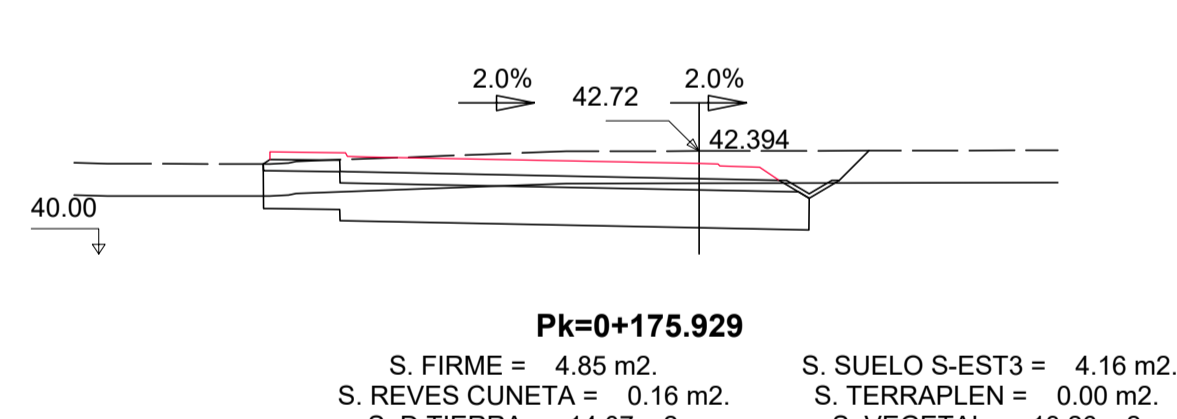
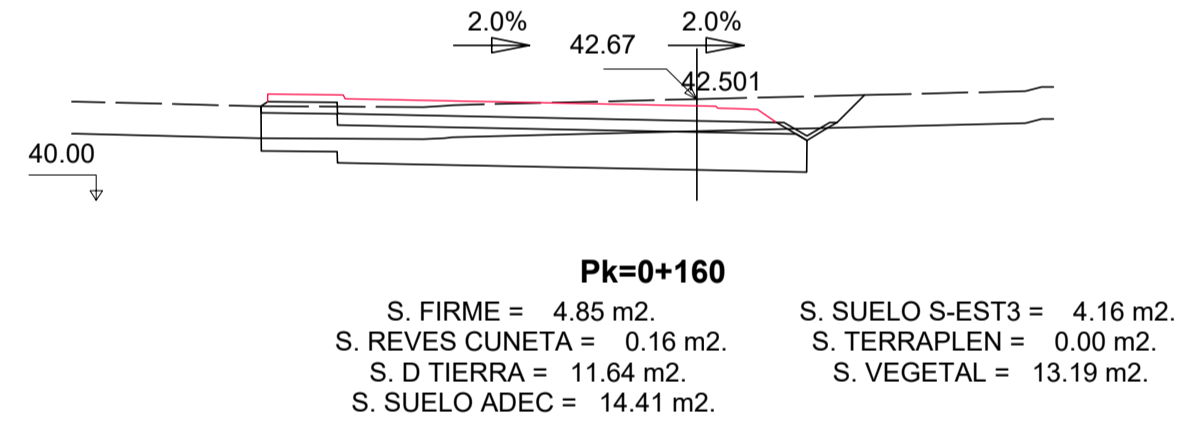
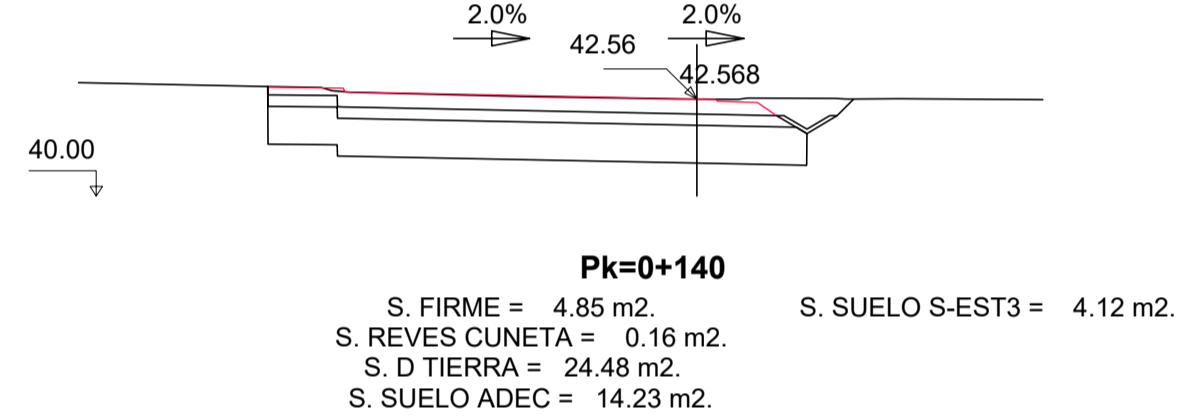
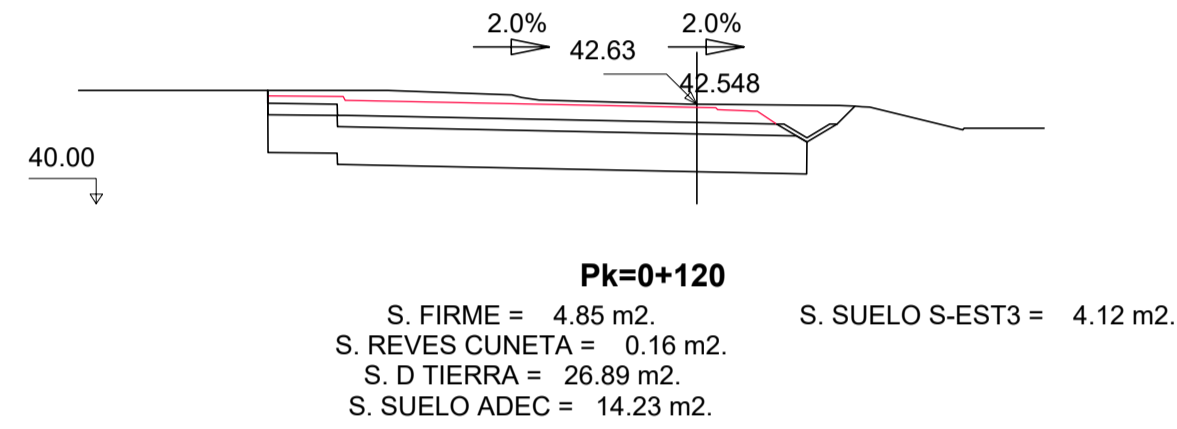
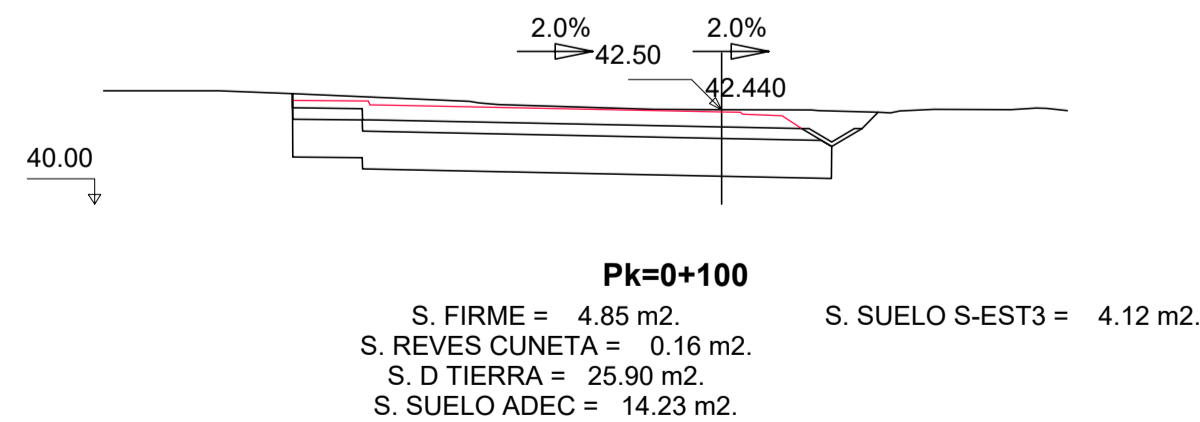
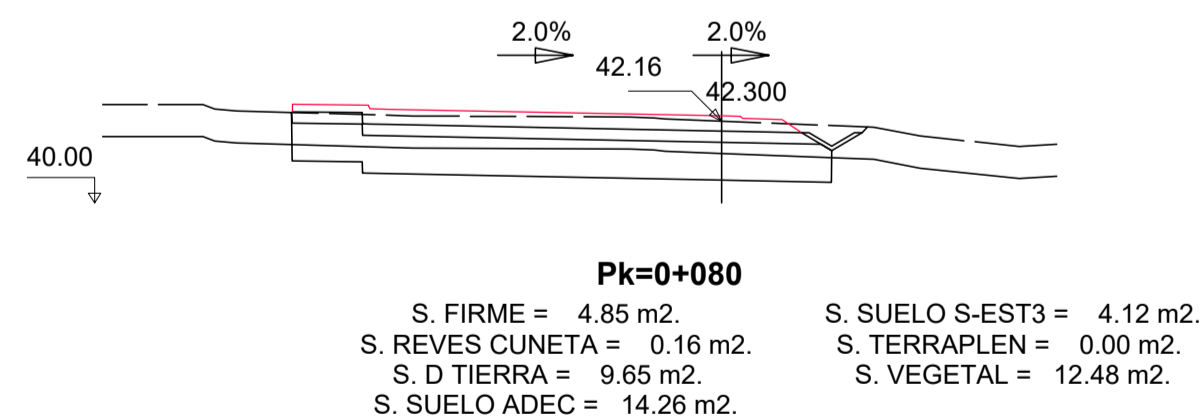
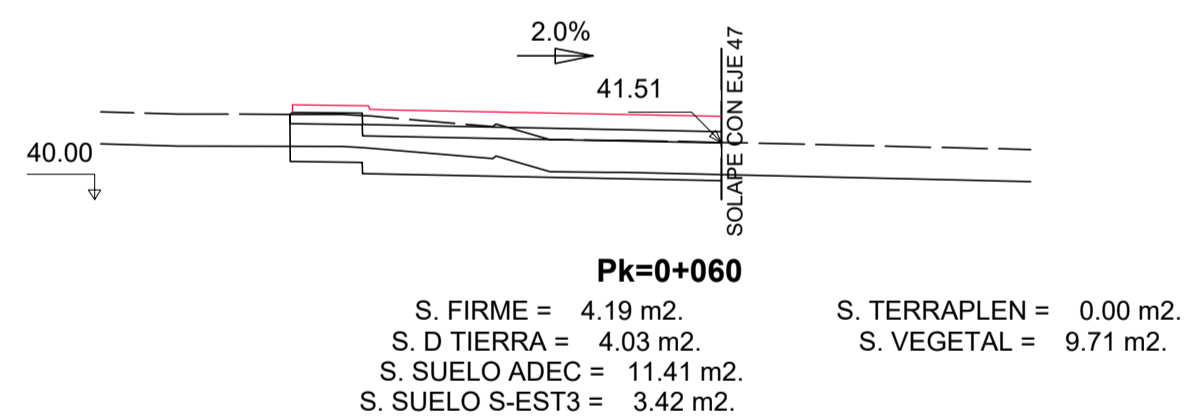
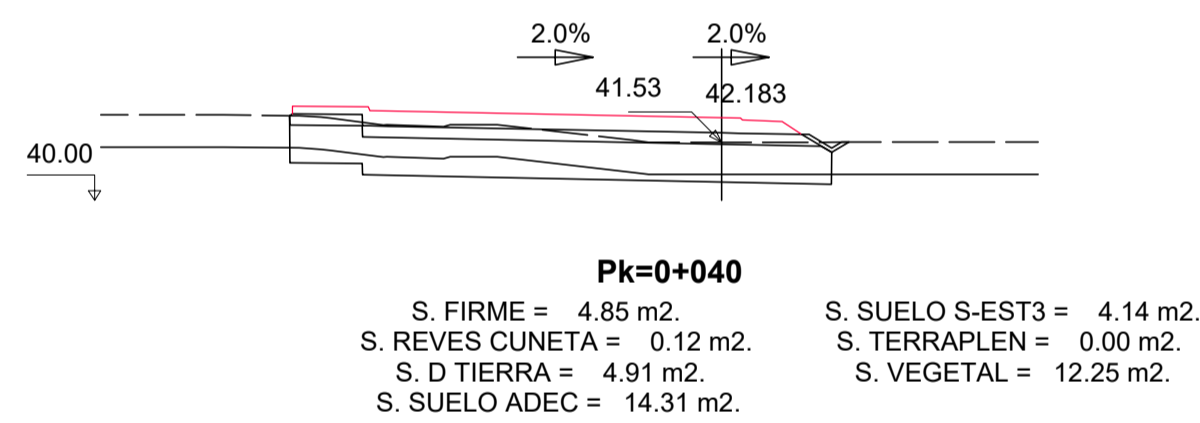
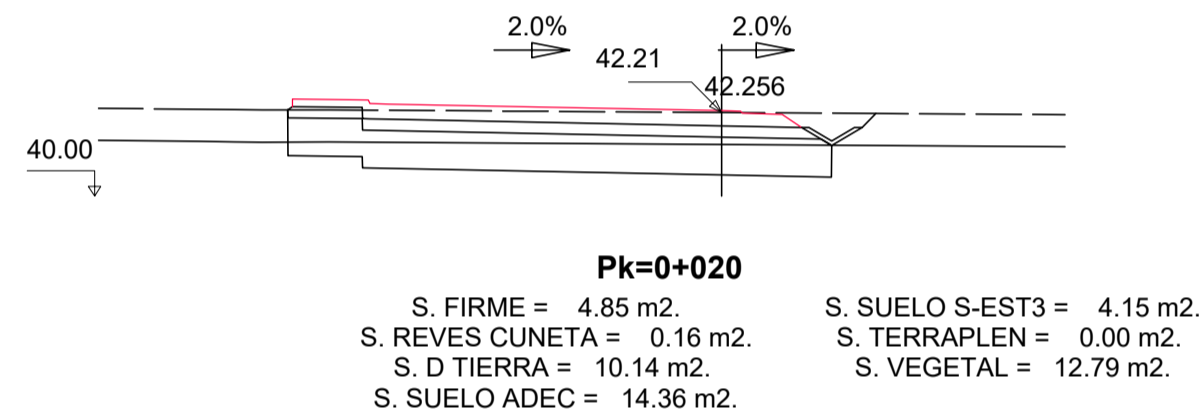
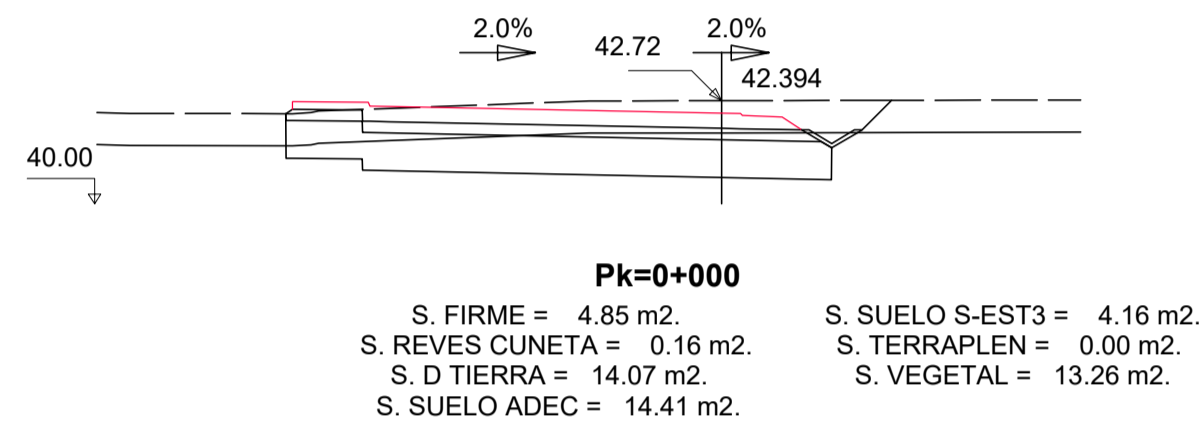

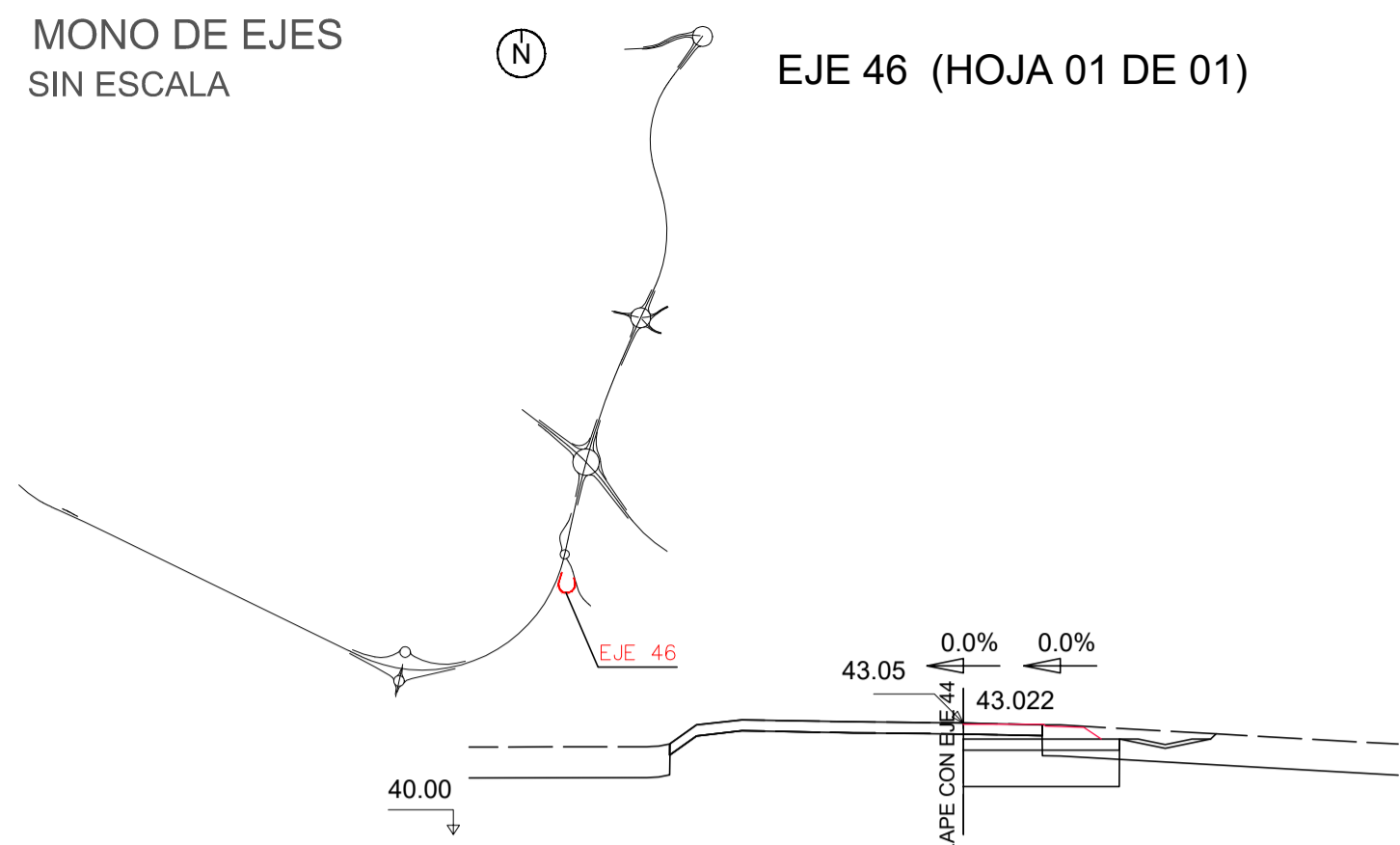

Pk=0+000
 S. FIRME = 1.36 m2. S. SUELO S-EST3 = 1.28 m2.
 S. REVES CUNETETA = 0.20 m2. S. TERRAPLEN = 0.00 m2.
 S. D TIERRA = 4.77 m2. S. VEGETAL = 2.69 m2.
 S. SUELO ADEC = 4.28 m2. S. DEMOLICION = 0.65 m2.

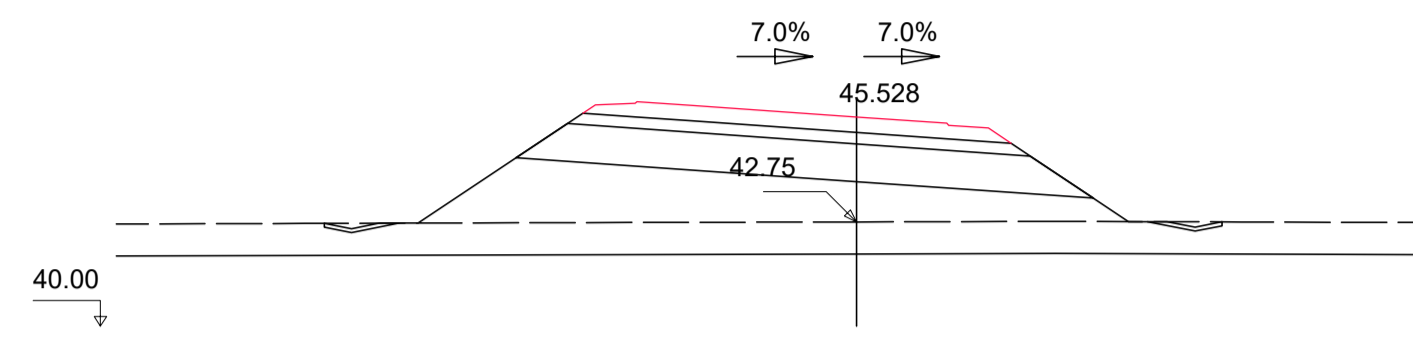

Pk=0+100
 S. FIRME = 4.24 m2. S. REV CUN GUARDA = 0.35 m2.
 S. SUELO ADEC = 13.76 m2. S. VEGETAL = 20.19 m2.
 S. SUELO S-EST3 = 3.54 m2.
 S. TERRAPLEN = 39.94 m2.

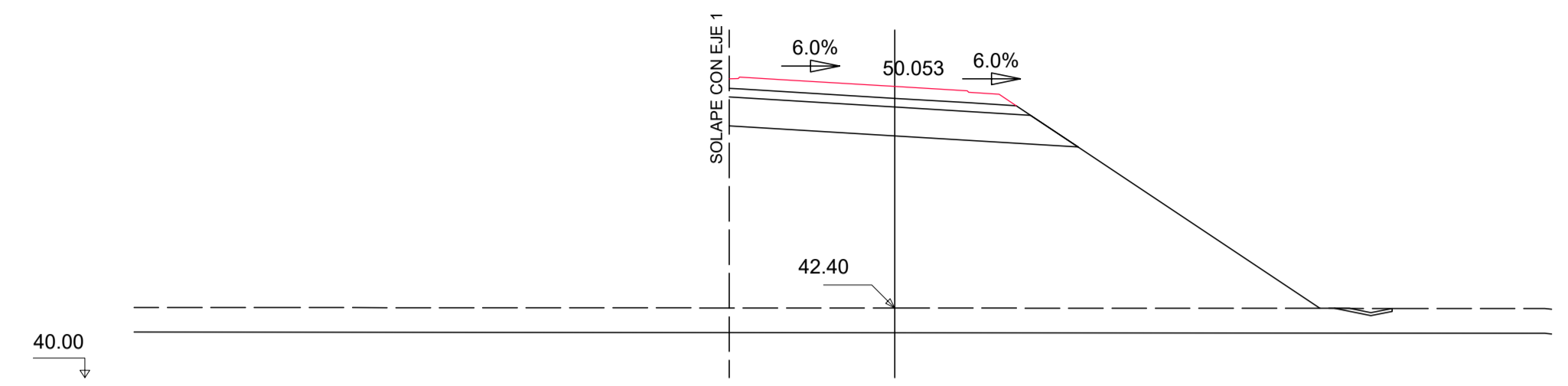

Pk=0+200
 S. FIRME = 3.86 m2. S. REV CUN GUARDA = 0.18 m2.
 S. SUELO ADEC = 11.24 m2. S. VEGETAL = 19.48 m2.
 S. SUELO S-EST3 = 3.05 m2.
 S. TERRAPLEN = 113.92 m2.

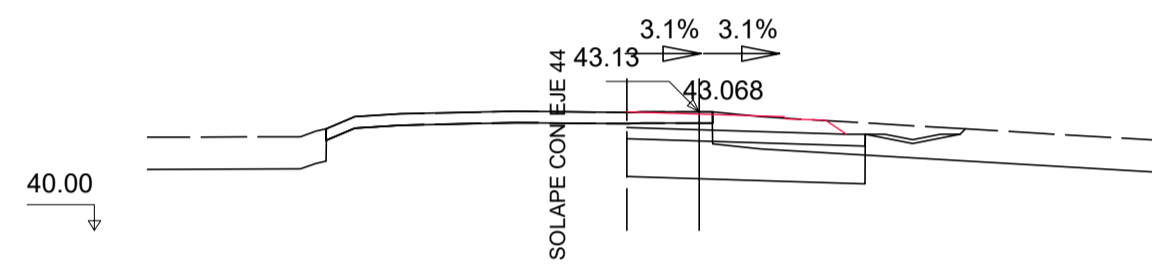

Pk=0+020
 S. FIRME = 2.19 m2. S. SUELO S-EST3 = 1.89 m2.
 S. REVES CUNETETA = 0.20 m2. S. TERRAPLEN = 0.00 m2.
 S. D TIERRA = 6.63 m2. S. VEGETAL = 4.32 m2.
 S. SUELO ADEC = 6.30 m2. S. DEMOLICION = 0.68 m2.

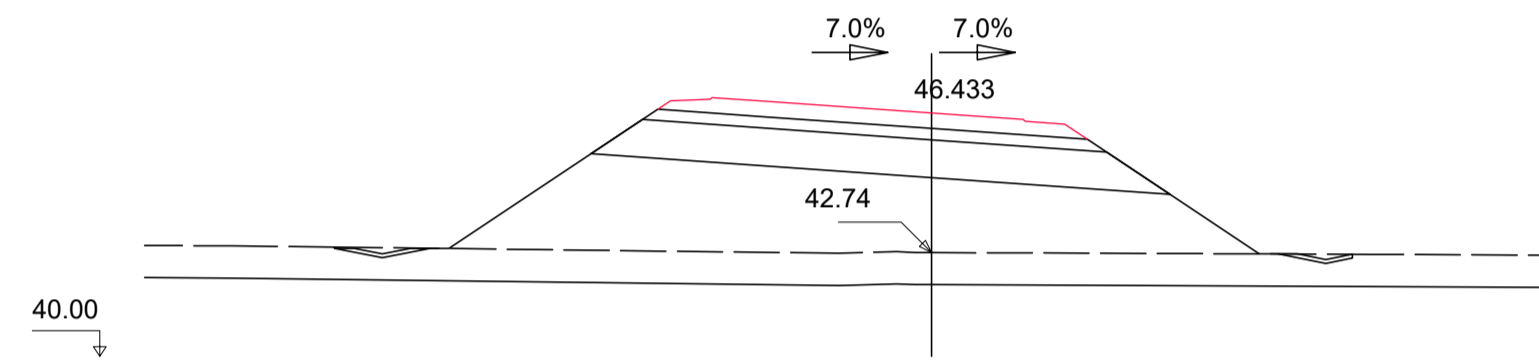

Pk=0+120
 S. FIRME = 4.26 m2. S. REV CUN GUARDA = 0.38 m2.
 S. SUELO ADEC = 13.80 m2. S. VEGETAL = 22.91 m2.
 S. SUELO S-EST3 = 3.55 m2.
 S. TERRAPLEN = 60.67 m2.

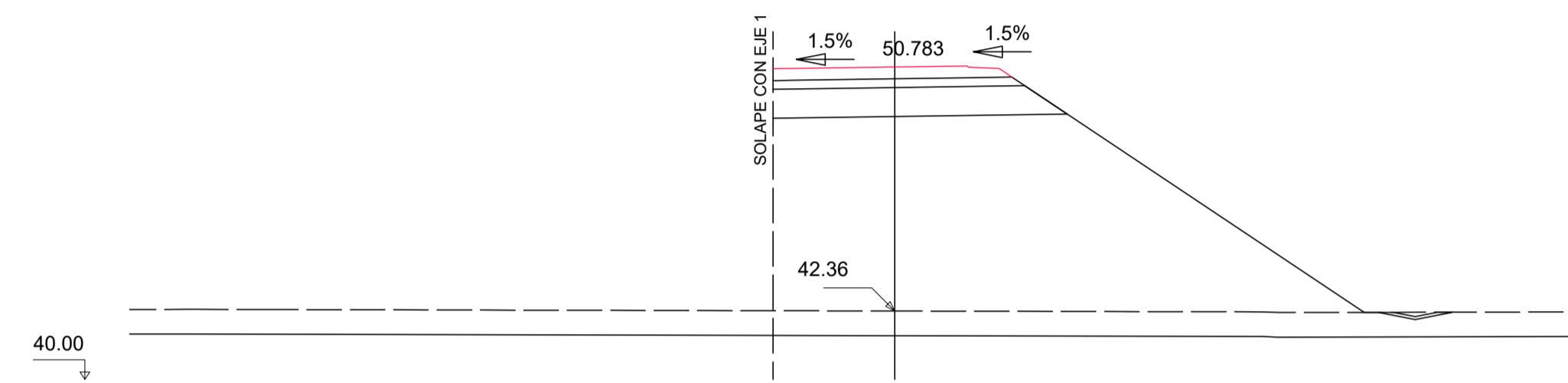

Pk=0+220
 S. FIRME = 3.19 m2. S. REV CUN GUARDA = 0.20 m2.
 S. SUELO ADEC = 9.43 m2. S. VEGETAL = 19.95 m2.
 S. SUELO S-EST3 = 2.54 m2.
 S. TERRAPLEN = 123.07 m2.

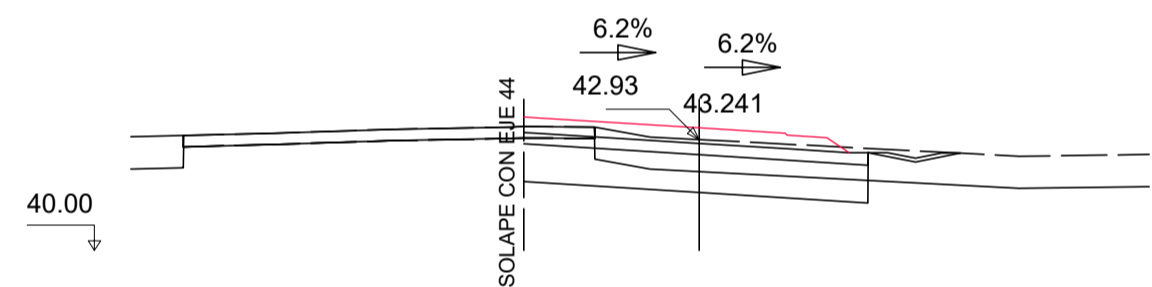

Pk=0+040
 S. FIRME = 3.34 m2. S. SUELO S-EST3 = 2.74 m2.
 S. REVES CUNETETA = 0.20 m2. S. TERRAPLEN = 0.00 m2.
 S. D TIERRA = 6.45 m2. S. VEGETAL = 6.59 m2.
 S. SUELO ADEC = 9.11 m2. S. DEMOLICION = 0.56 m2.

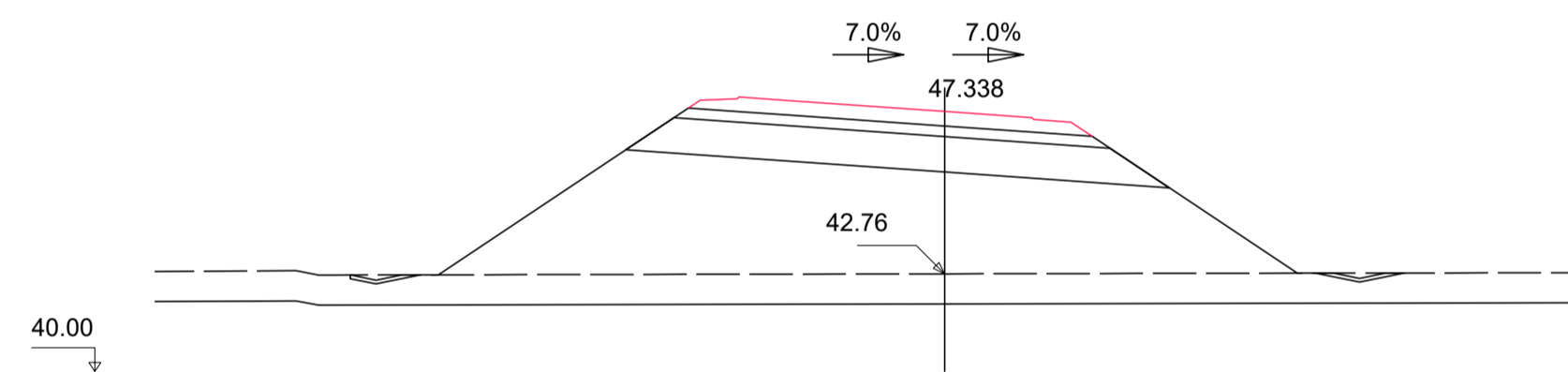

Pk=0+140
 S. FIRME = 4.27 m2. S. REV CUN GUARDA = 0.38 m2.
 S. SUELO ADEC = 13.83 m2. S. VEGETAL = 25.31 m2.
 S. SUELO S-EST3 = 3.56 m2.
 S. TERRAPLEN = 83.95 m2.

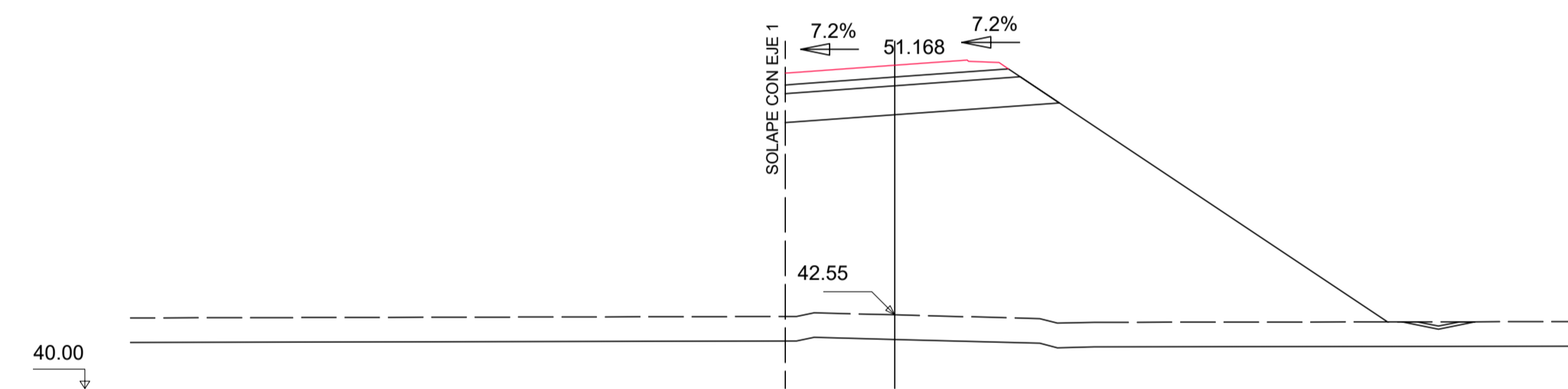

Pk=0+240
 S. FIRME = 2.95 m2. S. REV CUN GUARDA = 0.20 m2.
 S. SUELO ADEC = 8.80 m2. S. VEGETAL = 20.27 m2.
 S. SUELO S-EST3 = 2.38 m2.
 S. TERRAPLEN = 129.50 m2.

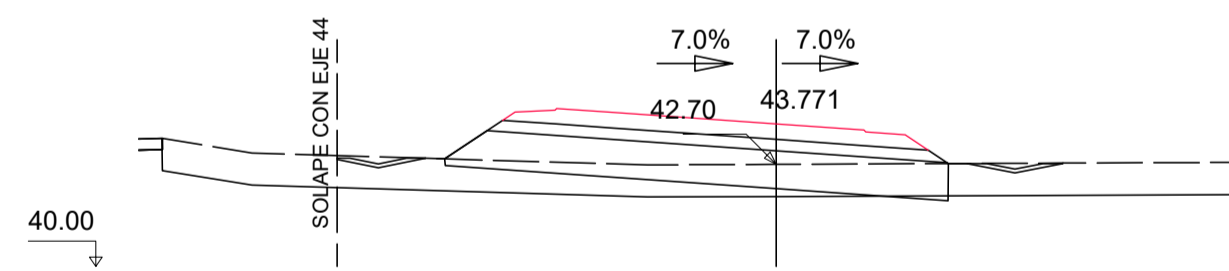

Pk=0+060
 S. FIRME = 4.21 m2. S. TERRAPLEN = 8.77 m2.
 S. D TIERRA = 0.11 m2. S. REV CUN GUARDA = 0.41 m2.
 S. SUELO ADEC = 12.85 m2. S. VEGETAL = 16.32 m2.
 S. SUELO S-EST3 = 3.51 m2.

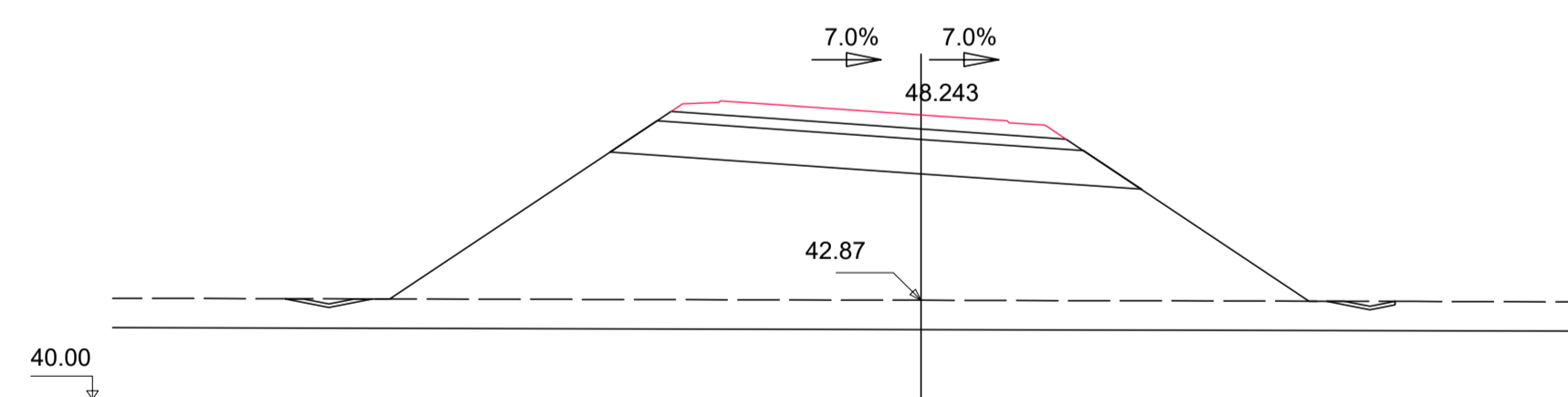

Pk=0+160
 S. FIRME = 4.29 m2. S. REV CUN GUARDA = 0.38 m2.
 S. SUELO ADEC = 13.87 m2. S. VEGETAL = 27.32 m2.
 S. SUELO S-EST3 = 3.57 m2.
 S. TERRAPLEN = 105.95 m2.

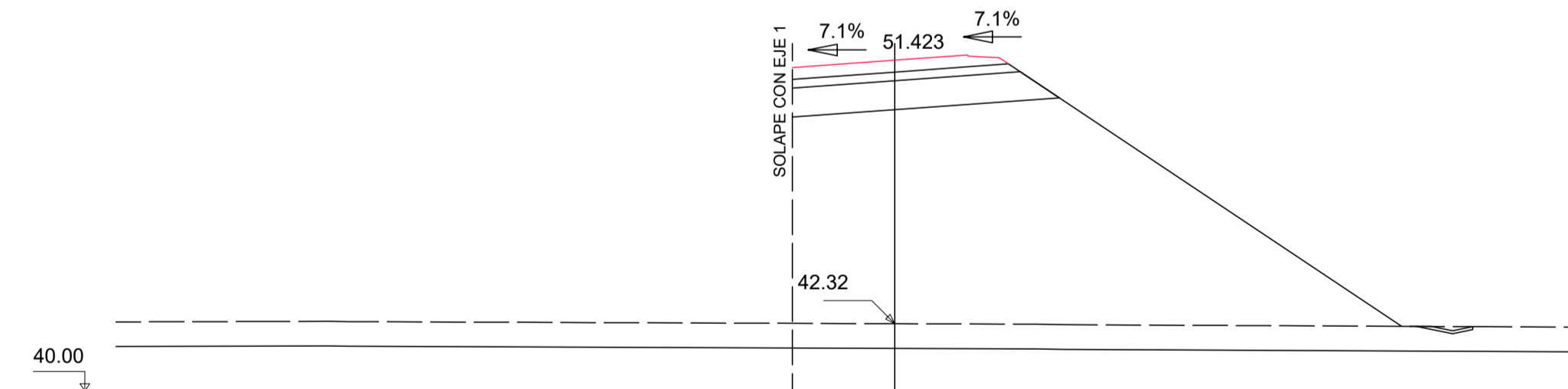

Pk=0+260
 S. FIRME = 2.85 m2. S. REV CUN GUARDA = 0.17 m2.
 S. SUELO ADEC = 8.55 m2. S. VEGETAL = 19.99 m2.
 S. SUELO S-EST3 = 2.30 m2.
 S. TERRAPLEN = 135.04 m2.

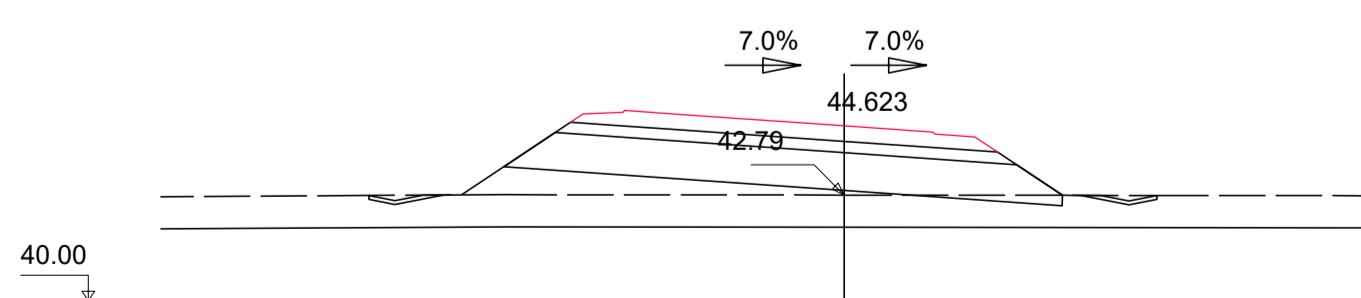

Pk=0+080
 S. FIRME = 4.23 m2. S. REV CUN GUARDA = 0.35 m2.
 S. SUELO ADEC = 13.66 m2. S. VEGETAL = 17.72 m2.
 S. SUELO S-EST3 = 3.52 m2.
 S. TERRAPLEN = 21.03 m2.

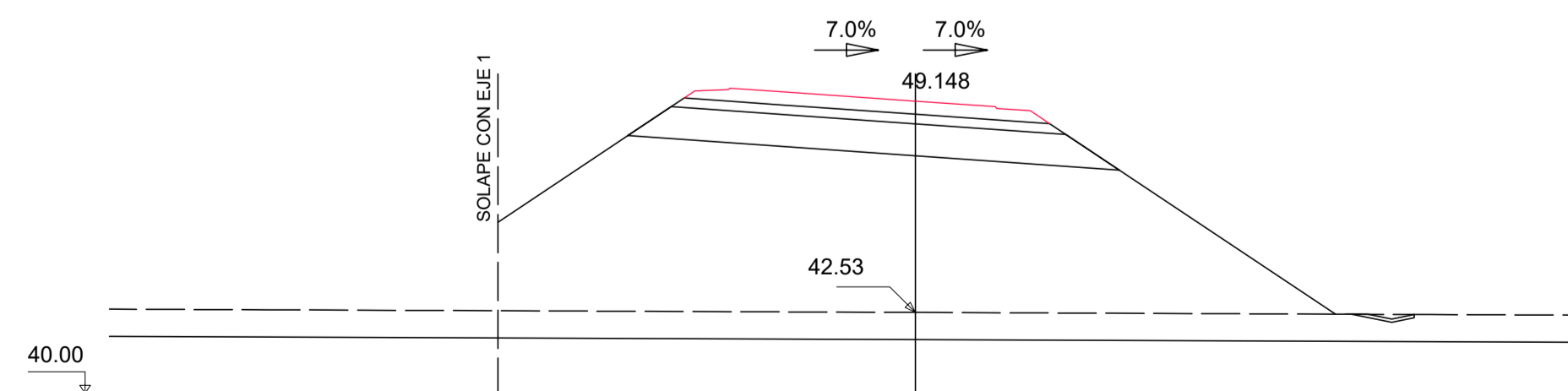

Pk=0+180
 S. FIRME = 4.29 m2. S. REV CUN GUARDA = 0.17 m2.
 S. SUELO ADEC = 13.87 m2. S. VEGETAL = 24.39 m2.
 S. SUELO S-EST3 = 3.57 m2.
 S. TERRAPLEN = 132.99 m2.

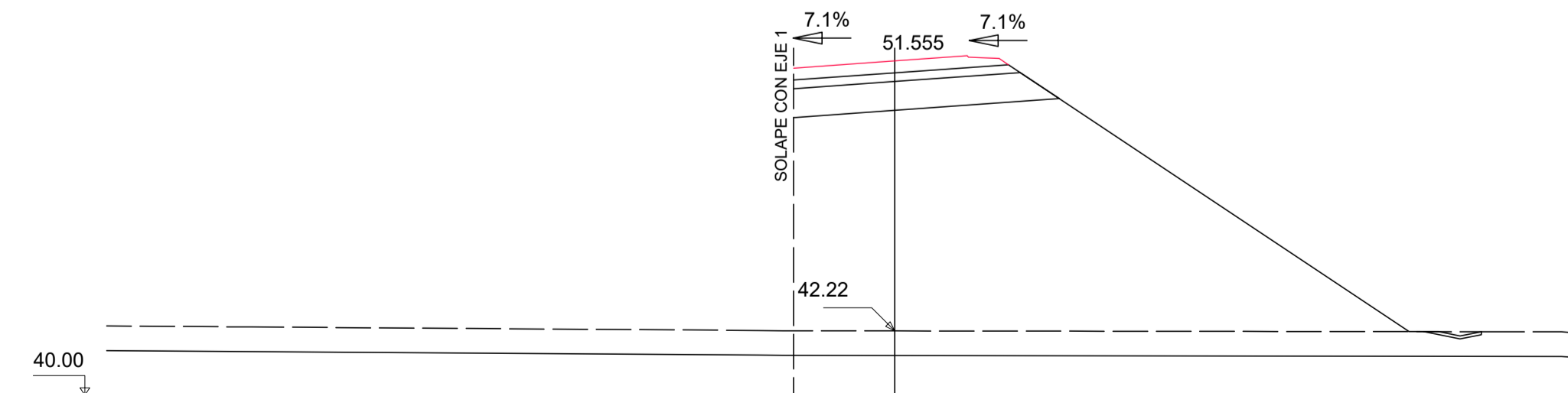

Pk=0+271.959
 S. FIRME = 2.83 m2. S. REV CUN GUARDA = 0.18 m2.
 S. SUELO ADEC = 8.51 m2. S. VEGETAL = 20.20 m2.
 S. SUELO S-EST3 = 2.29 m2.
 S. TERRAPLEN = 139.35 m2.

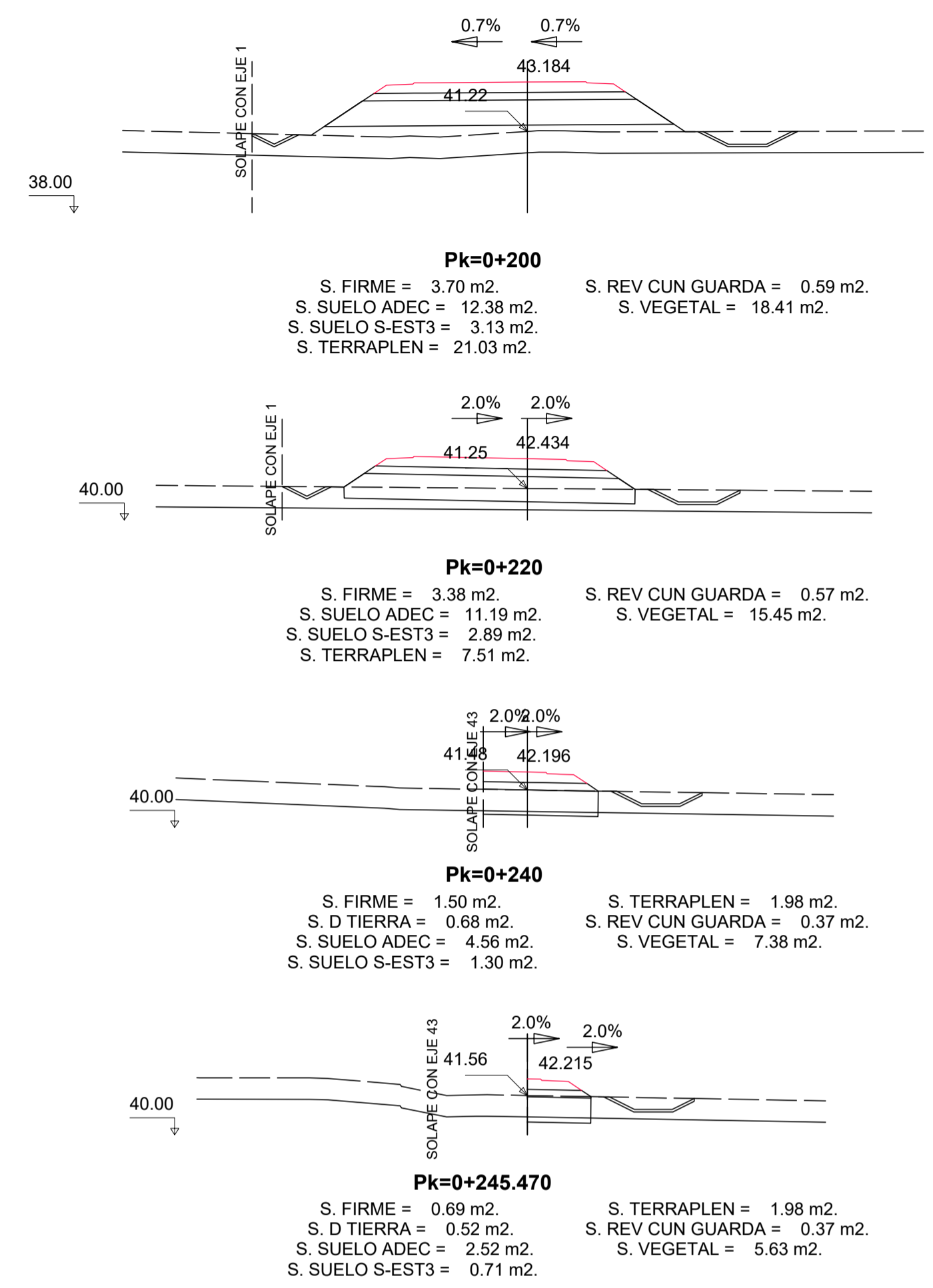
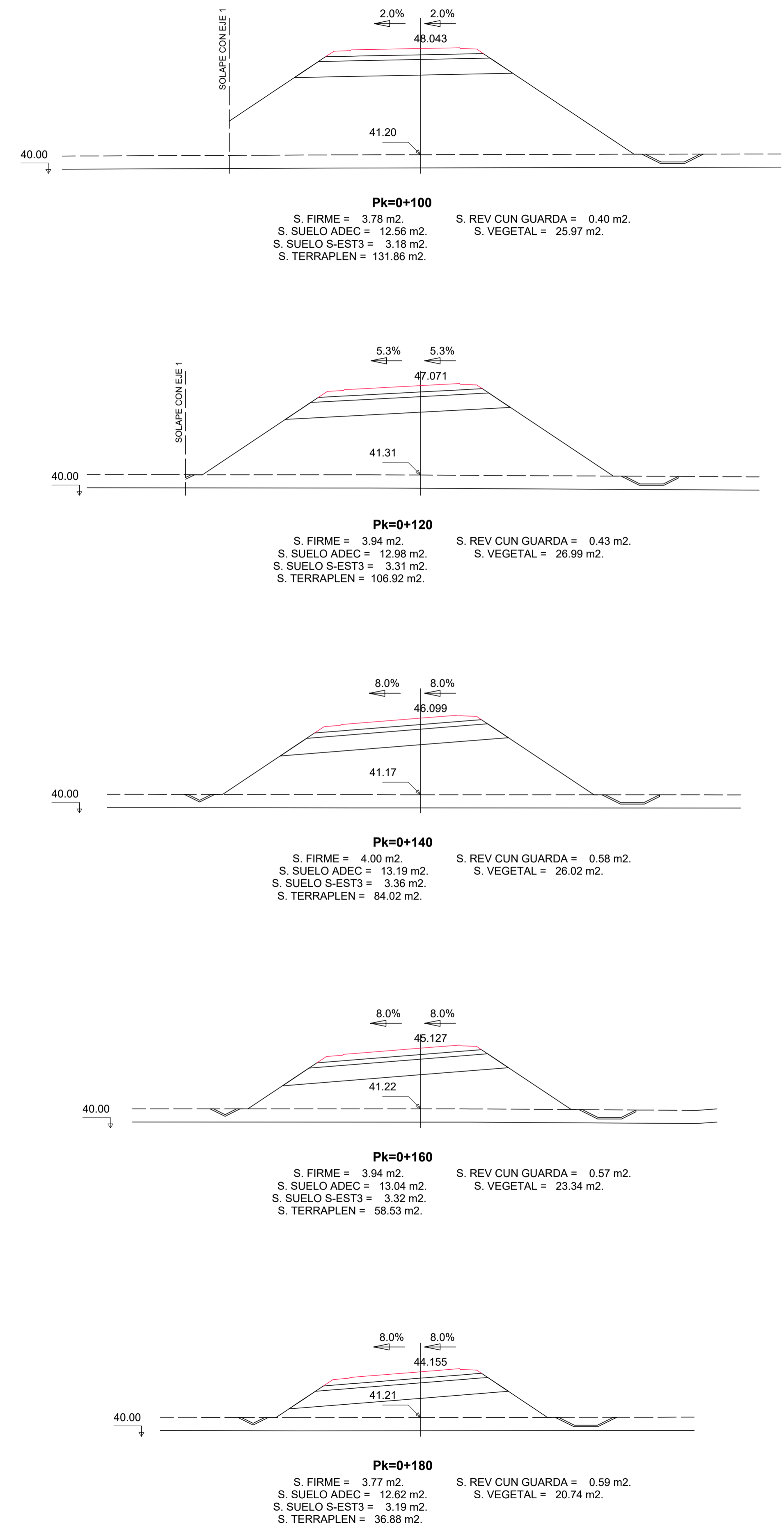
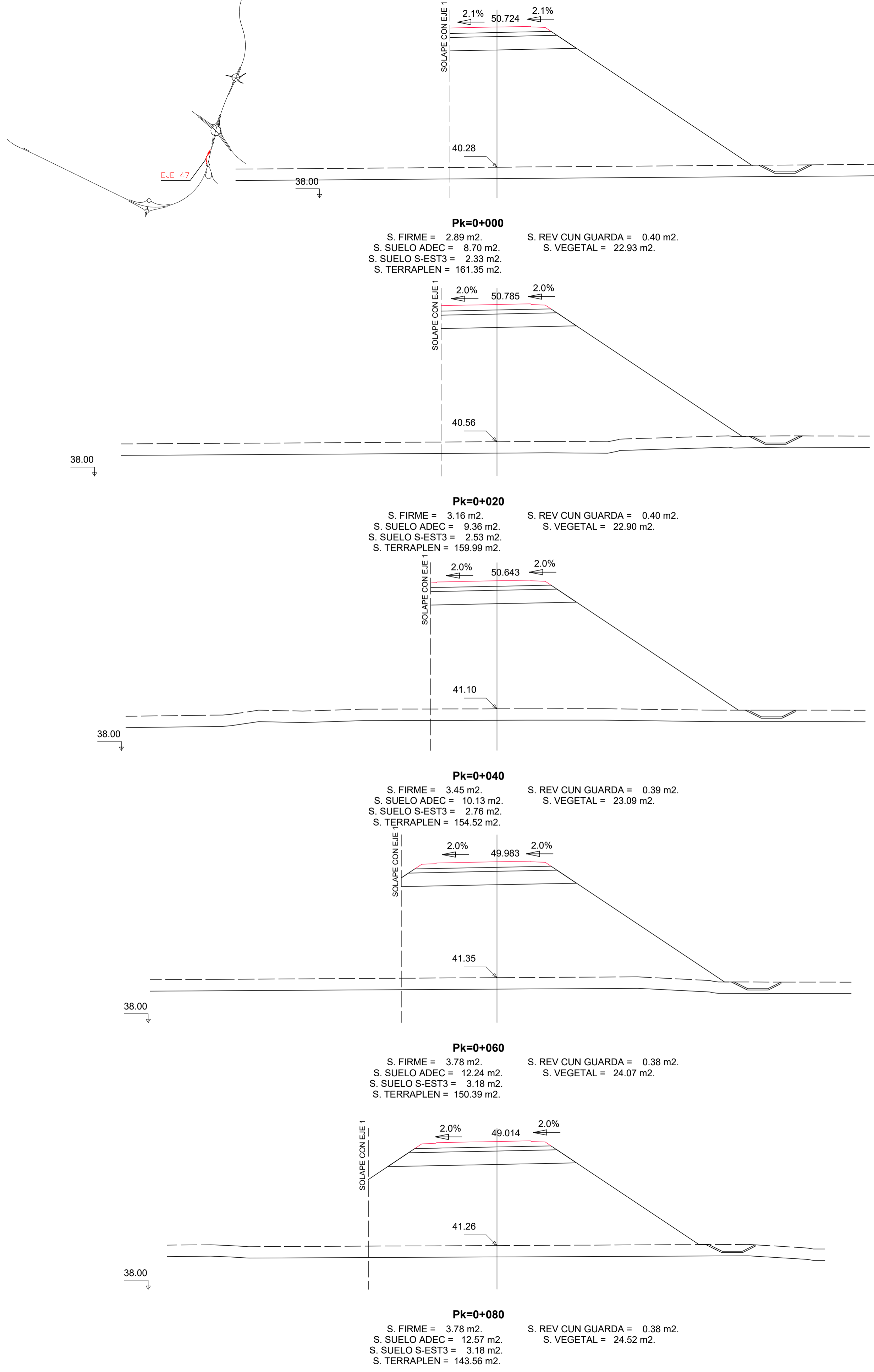

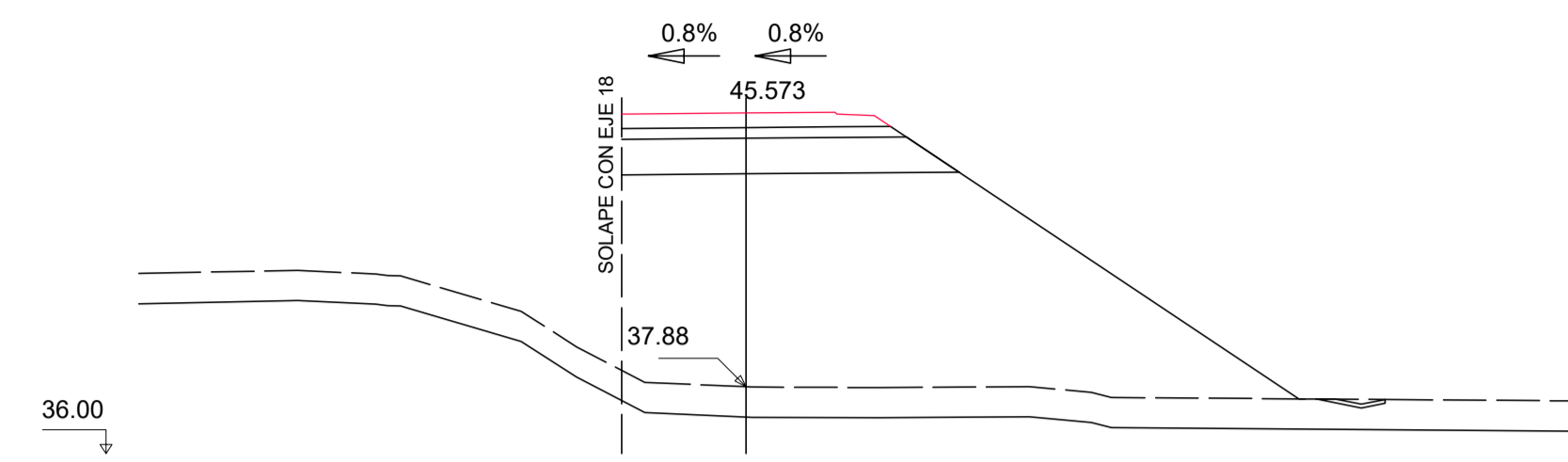
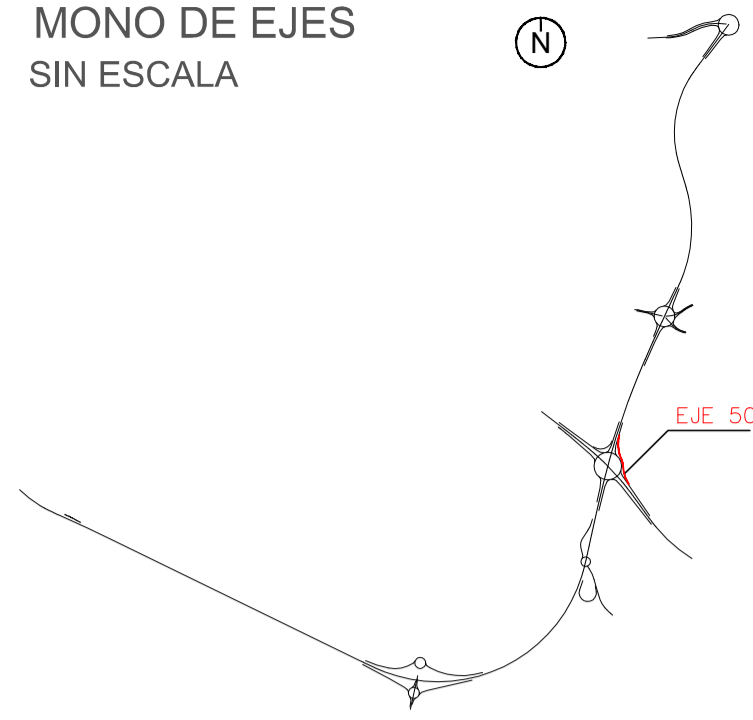

Pk=0+000
 S. FIRME = 2.90 m².
 S. SUELO ADEC = 8.75 m².
 S. SUELO S-EST3 = 2.34 m².
 S. TERRAPLEN = 103.77 m².
 S. REV CUN GUARDA = 0.17 m².
 S. VEGETAL = 18.25 m².

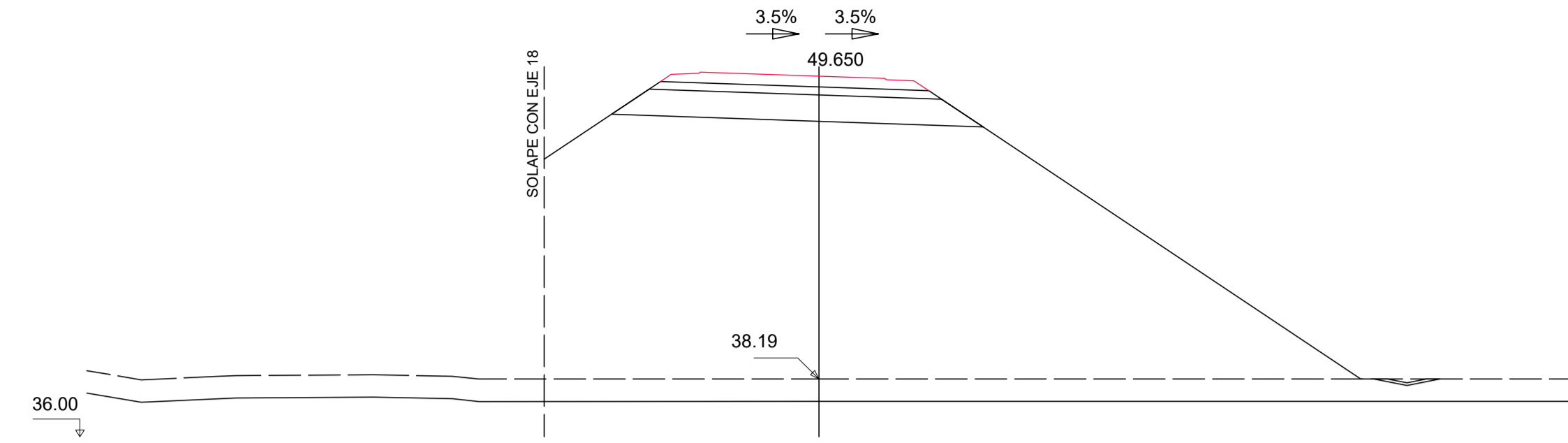

Pk=0+080
 S. FIRME = 3.78 m².
 S. SUELO ADEC = 12.58 m².
 S. SUELO S-EST3 = 3.19 m².
 S. TERRAPLEN = 257.94 m².
 S. REV CUN GUARDA = 0.20 m².
 S. VEGETAL = 28.85 m².

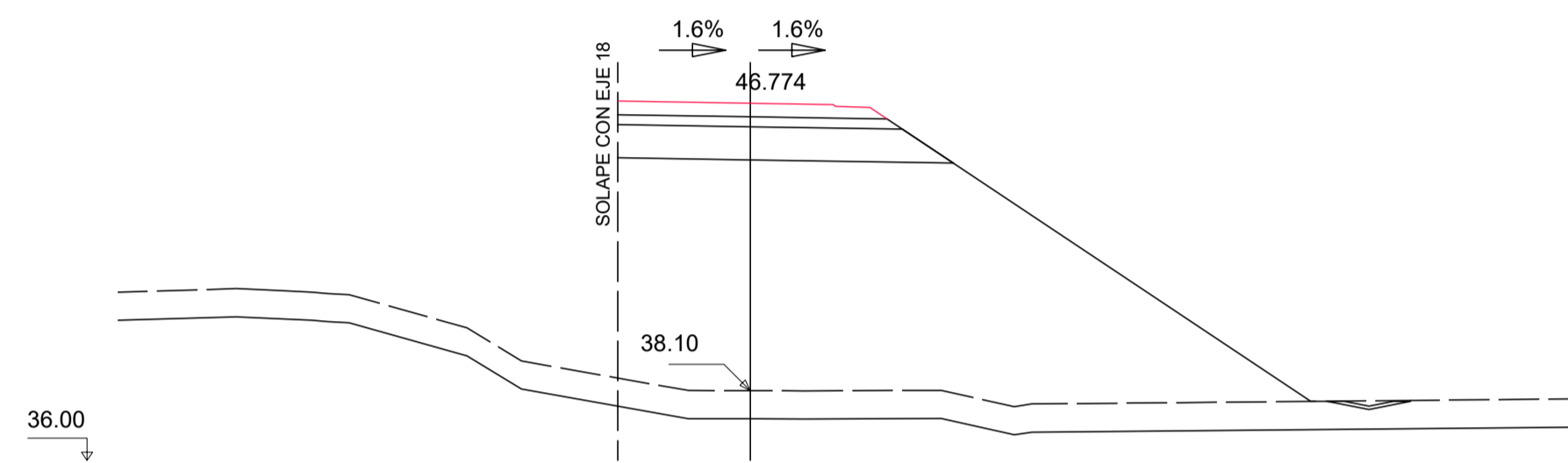

Pk=0+020
 S. FIRME = 3.14 m².
 S. SUELO ADEC = 9.35 m².
 S. SUELO S-EST3 = 2.51 m².
 S. TERRAPLEN = 128.87 m².
 S. REV CUN GUARDA = 0.20 m².
 S. VEGETAL = 20.33 m².

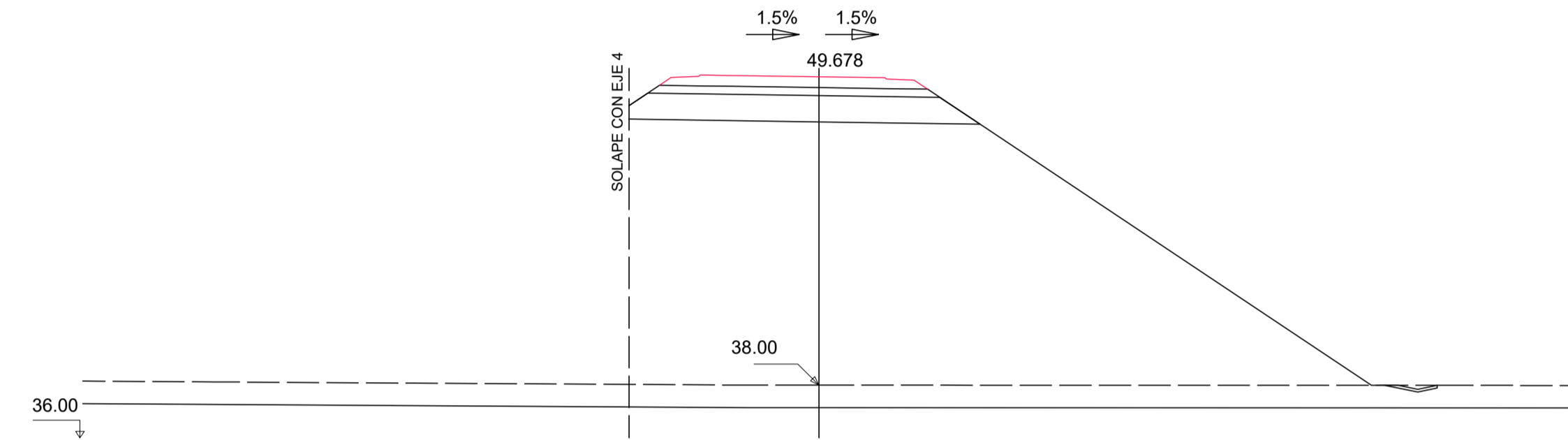

Pk=0+100
 S. FIRME = 3.78 m².
 S. SUELO ADEC = 12.37 m².
 S. SUELO S-EST3 = 3.18 m².
 S. TERRAPLEN = 231.73 m².
 S. REV CUN GUARDA = 0.18 m².
 S. VEGETAL = 26.03 m².

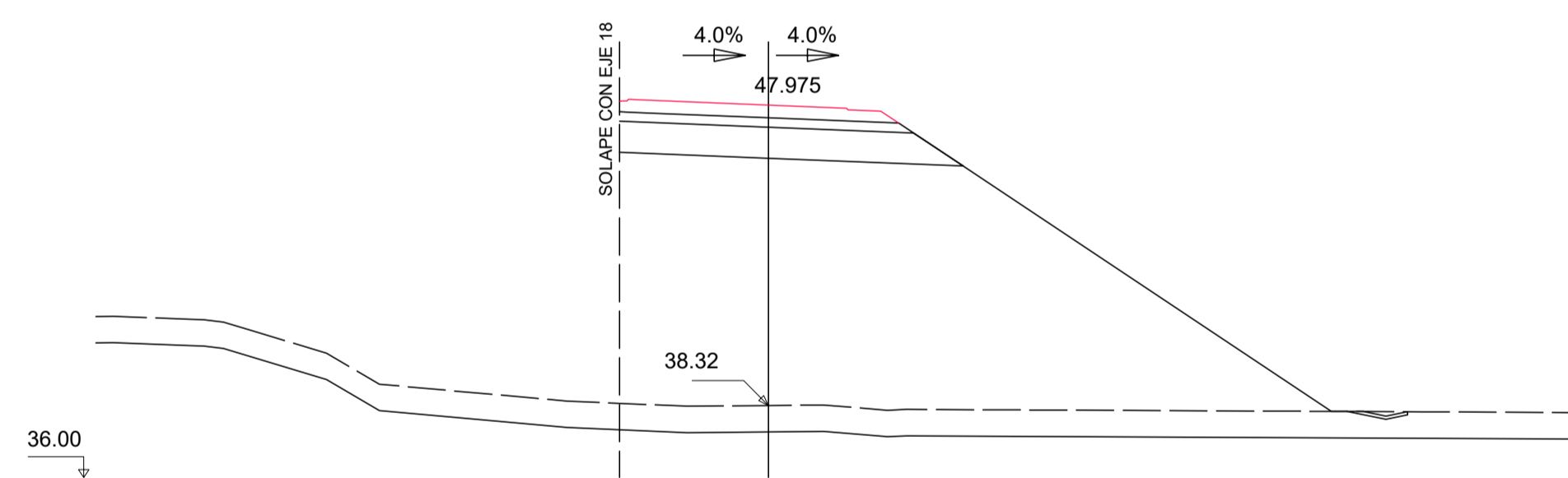

Pk=0+040
 S. FIRME = 3.47 m².
 S. SUELO ADEC = 10.24 m².
 S. SUELO S-EST3 = 2.76 m².
 S. TERRAPLEN = 155.45 m².
 S. REV CUN GUARDA = 0.17 m².
 S. VEGETAL = 21.52 m².

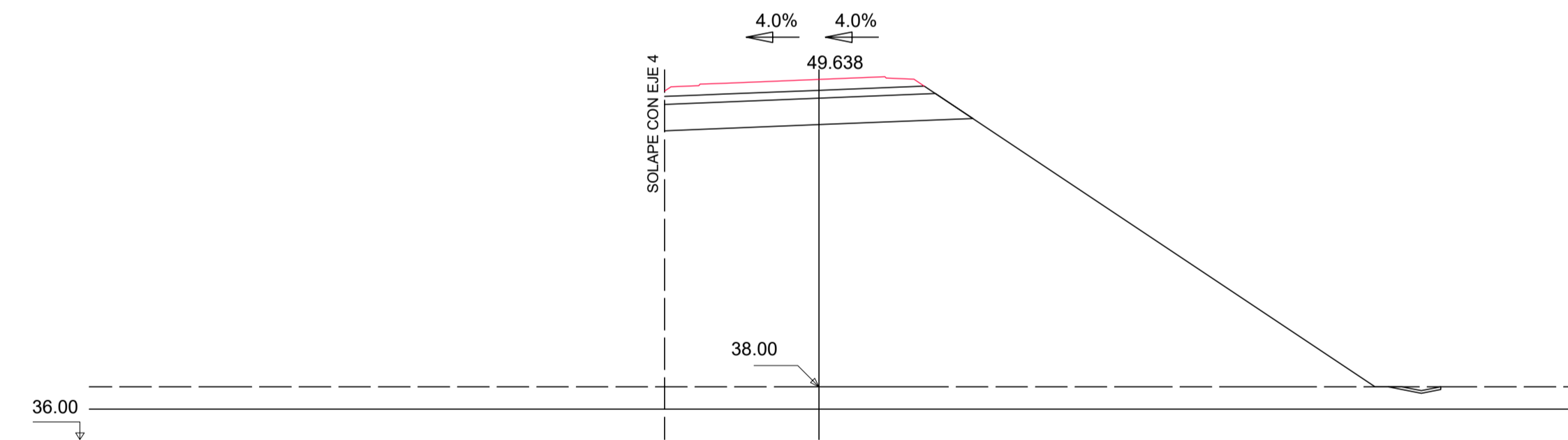

Pk=0+120
 S. FIRME = 3.74 m².
 S. SUELO ADEC = 10.97 m².
 S. SUELO S-EST3 = 3.02 m².
 S. TERRAPLEN = 218.11 m².
 S. REV CUN GUARDA = 0.18 m².
 S. VEGETAL = 25.00 m².

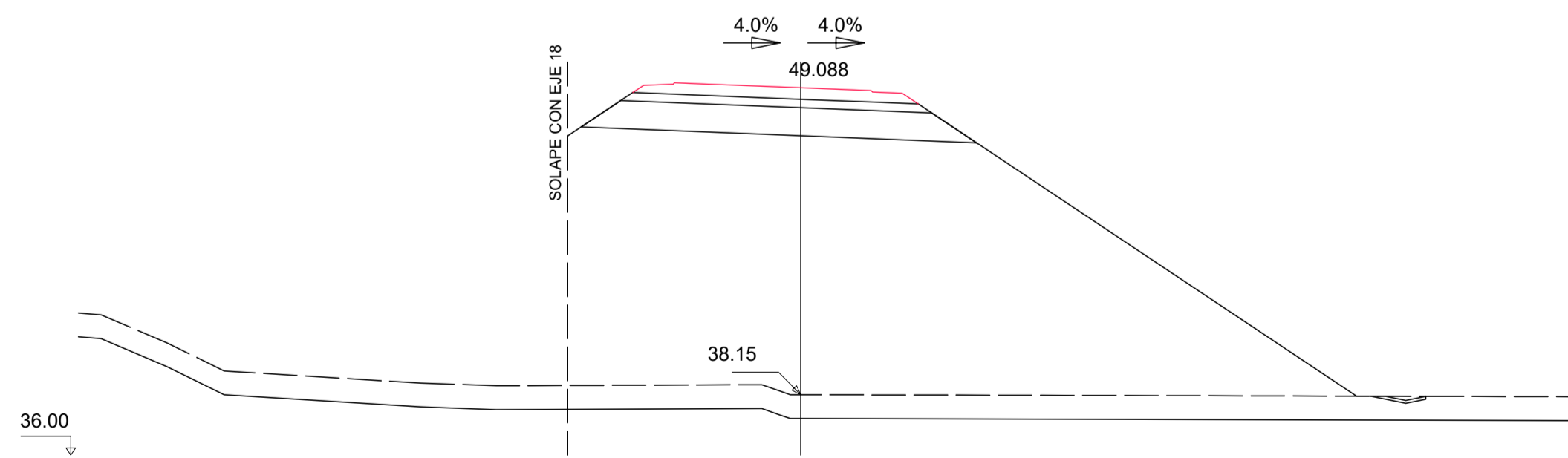

Pk=0+060
 S. FIRME = 3.78 m².
 S. SUELO ADEC = 12.57 m².
 S. SUELO S-EST3 = 3.19 m².
 S. TERRAPLEN = 218.88 m².
 S. REV CUN GUARDA = 0.17 m².
 S. VEGETAL = 25.98 m².

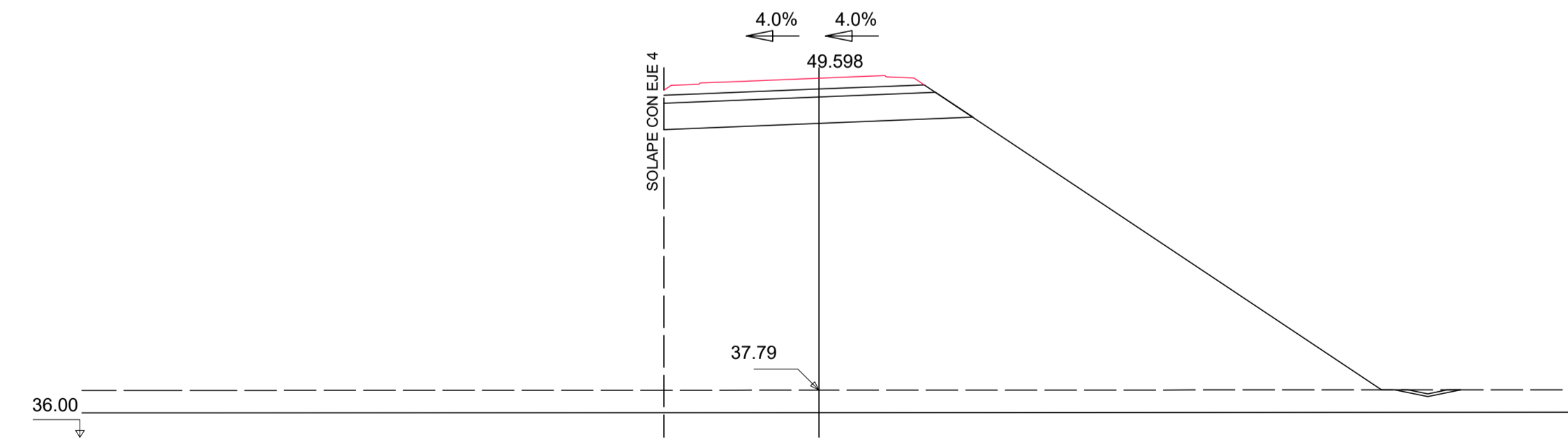

Pk=0+140
 S. FIRME = 3.75 m².
 S. SUELO ADEC = 10.99 m².
 S. SUELO S-EST3 = 3.02 m².
 S. TERRAPLEN = 223.56 m².
 S. REV CUN GUARDA = 0.20 m².
 S. VEGETAL = 25.66 m².

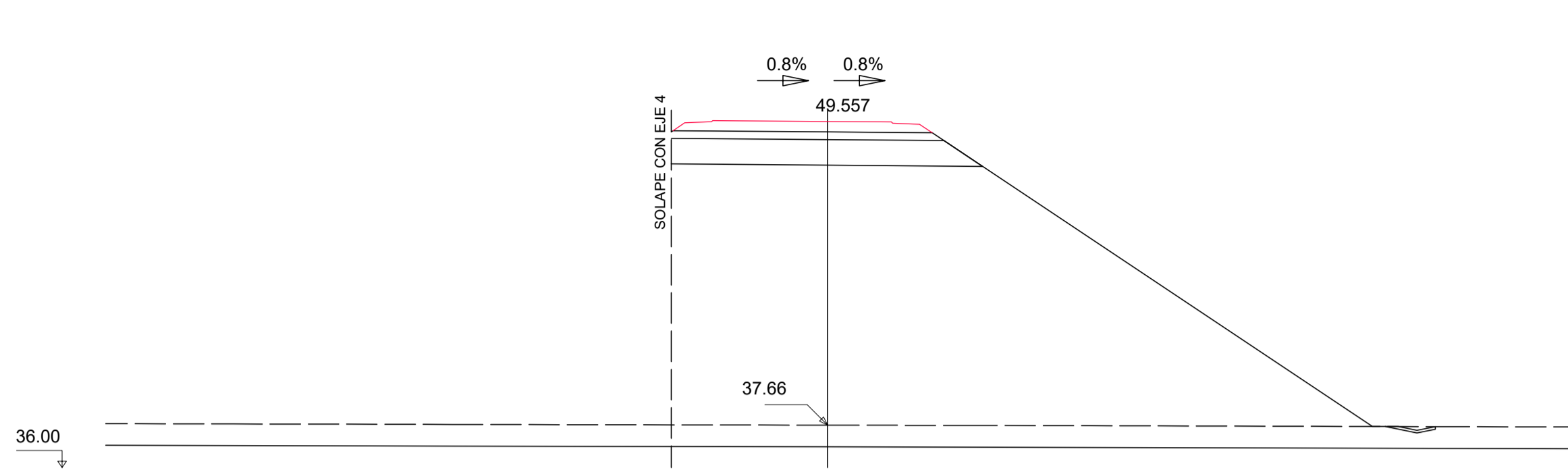
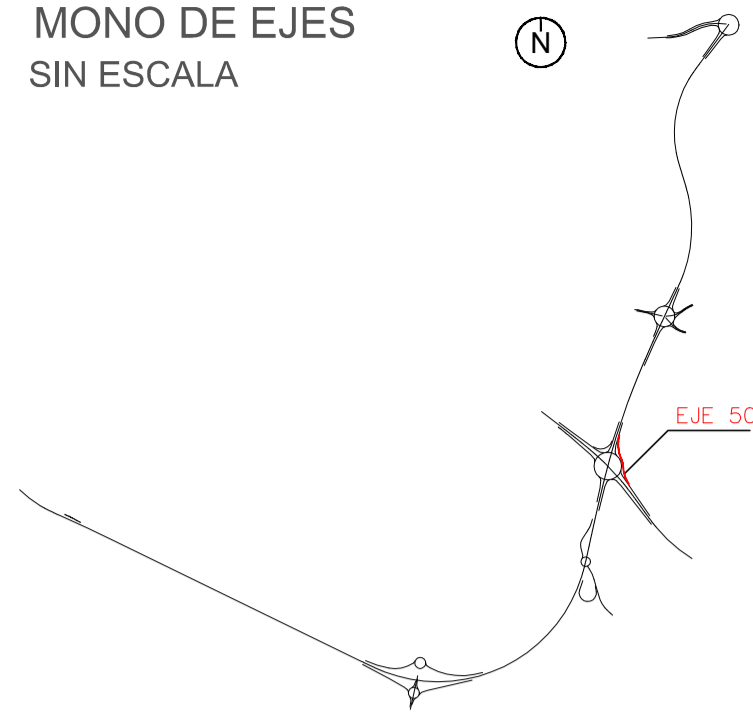

Pk=0+160
 S. FIRME = 3.78 m². S. REV CUN GUARDA = 0.17 m².
 S. SUELO ADEC = 11.44 m². S. VEGETAL = 25.45 m².
 S. SUELO S-EST3 = 3.13 m².
 S. TERRAPLEN = 226.90 m².

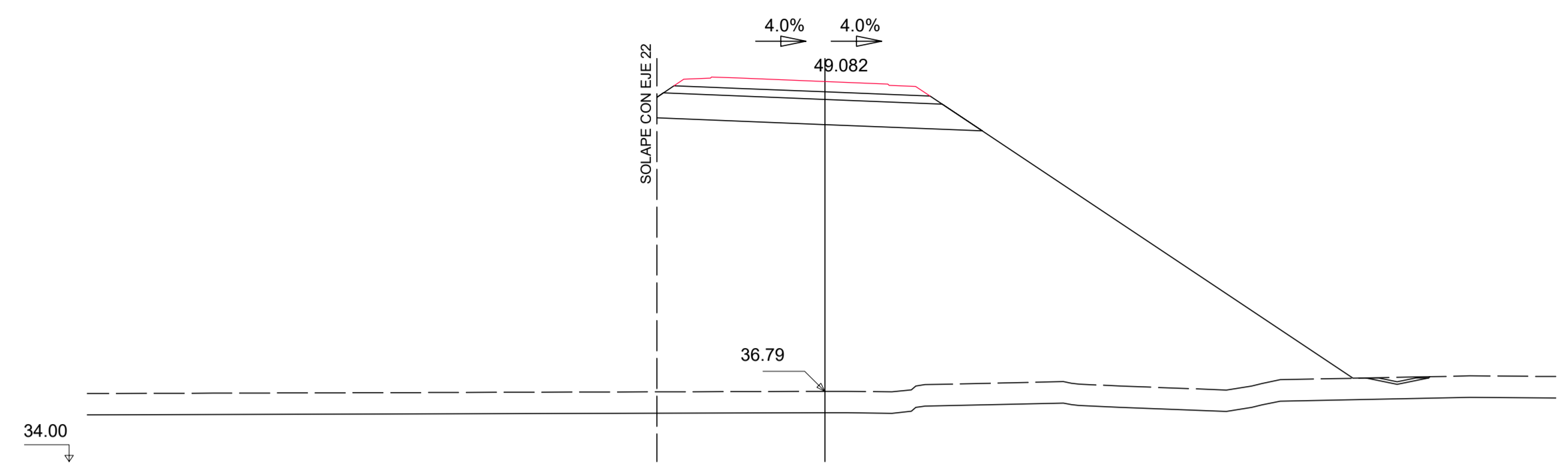

Pk=0+240
 S. FIRME = 3.78 m². S. REV CUN GUARDA = 0.20 m².
 S. SUELO ADEC = 12.10 m². S. VEGETAL = 26.09 m².
 S. SUELO S-EST3 = 3.19 m².
 S. TERRAPLEN = 237.48 m².

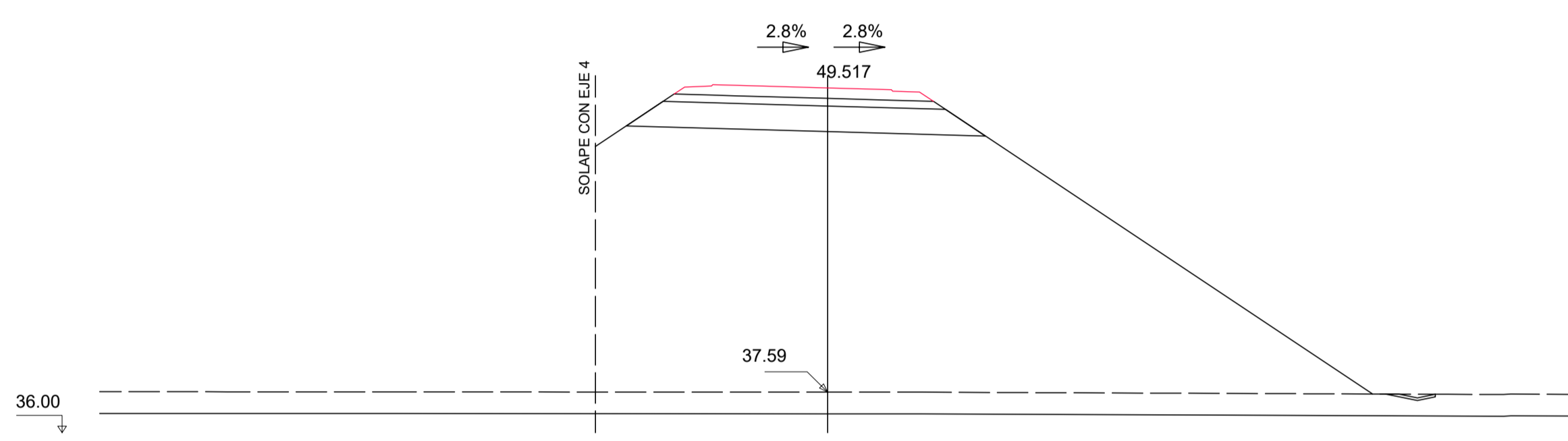

Pk=0+180
 S. FIRME = 3.78 m². S. REV CUN GUARDA = 0.17 m².
 S. SUELO ADEC = 12.57 m². S. VEGETAL = 27.97 m².
 S. SUELO S-EST3 = 3.18 m².
 S. TERRAPLEN = 260.30 m².

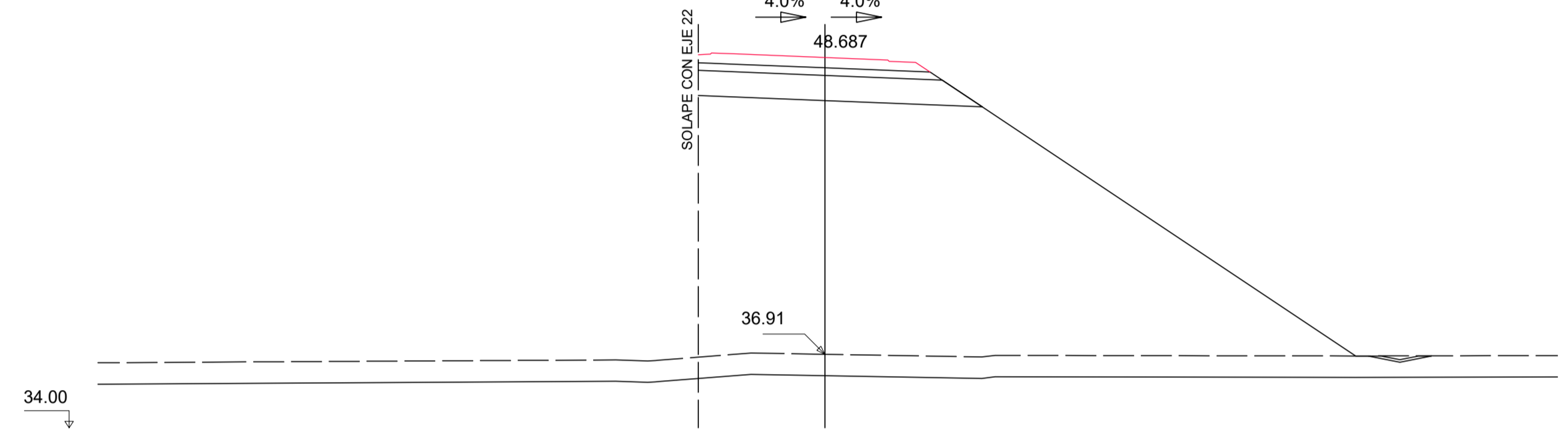

Pk=0+260
 S. FIRME = 3.55 m². S. REV CUN GUARDA = 0.20 m².
 S. SUELO ADEC = 10.48 m². S. VEGETAL = 24.74 m².
 S. SUELO S-EST3 = 2.83 m².
 S. TERRAPLEN = 211.03 m².

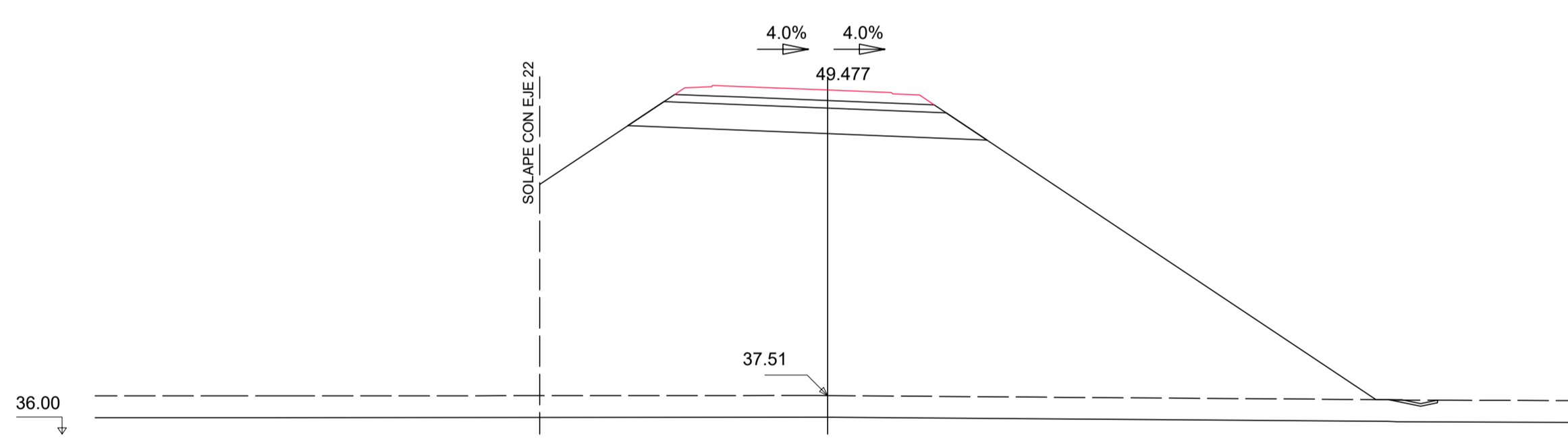

Pk=0+200
 S. FIRME = 3.78 m². S. REV CUN GUARDA = 0.17 m².
 S. SUELO ADEC = 12.57 m². S. VEGETAL = 29.91 m².
 S. SUELO S-EST3 = 3.19 m².
 S. TERRAPLEN = 283.77 m².

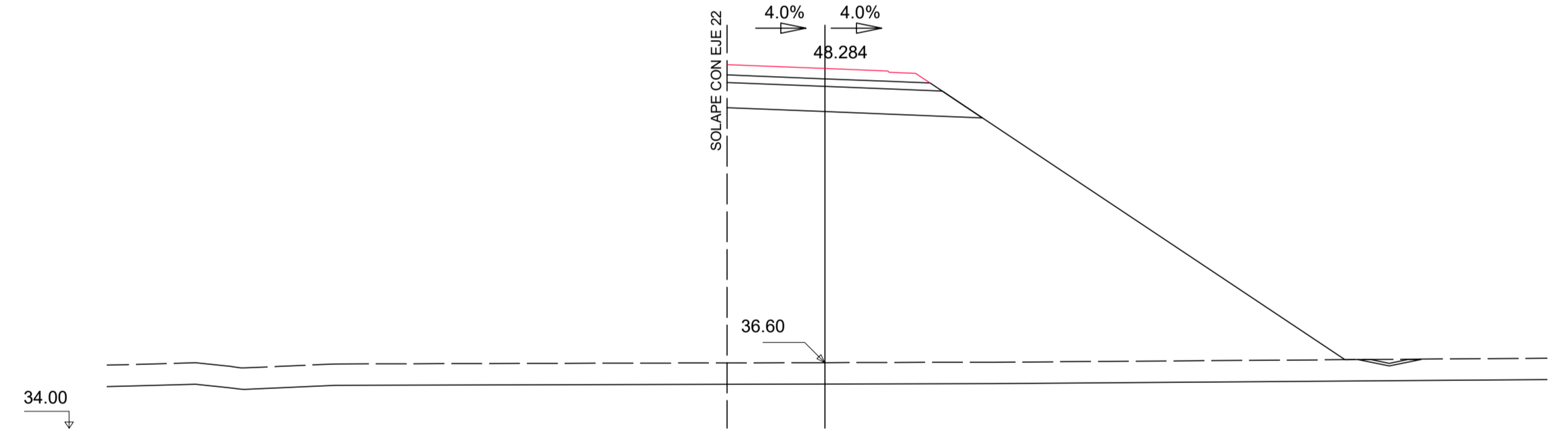

Pk=0+280
 S. FIRME = 3.12 m². S. REV CUN GUARDA = 0.20 m².
 S. SUELO ADEC = 9.33 m². S. VEGETAL = 23.42 m².
 S. SUELO S-EST3 = 2.49 m².
 S. TERRAPLEN = 193.47 m².

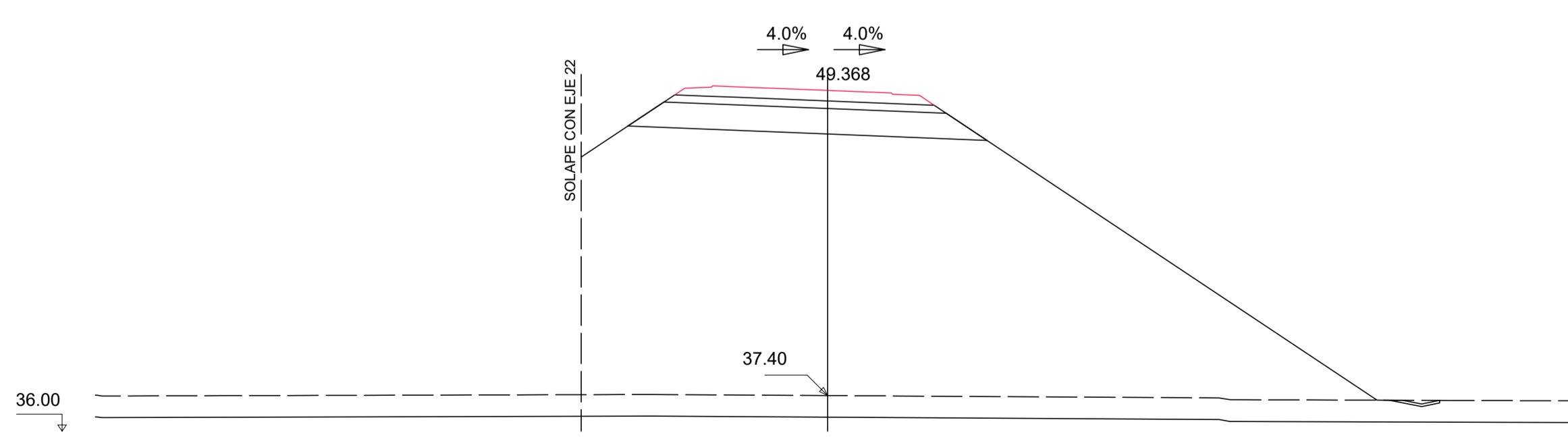

Pk=0+220
 S. FIRME = 3.78 m². S. REV CUN GUARDA = 0.17 m².
 S. SUELO ADEC = 12.57 m². S. VEGETAL = 28.60 m².
 S. SUELO S-EST3 = 3.18 m².
 S. TERRAPLEN = 267.91 m².

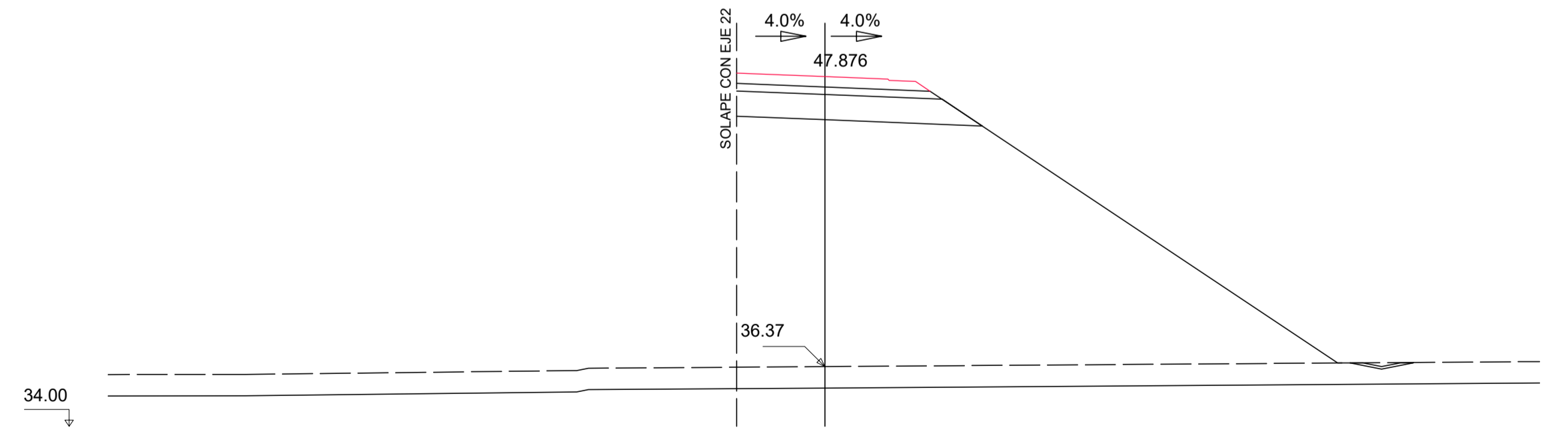

Pk=0+298.117
 S. FIRME = 2.96 m². S. REV CUN GUARDA = 0.20 m².
 S. SUELO ADEC = 8.95 m². S. VEGETAL = 22.84 m².
 S. SUELO S-EST3 = 2.37 m².
 S. TERRAPLEN = 184.32 m².

MONO DE EJES
SIN ESCALA



EJE 51 (HOJA 01 DE 01)

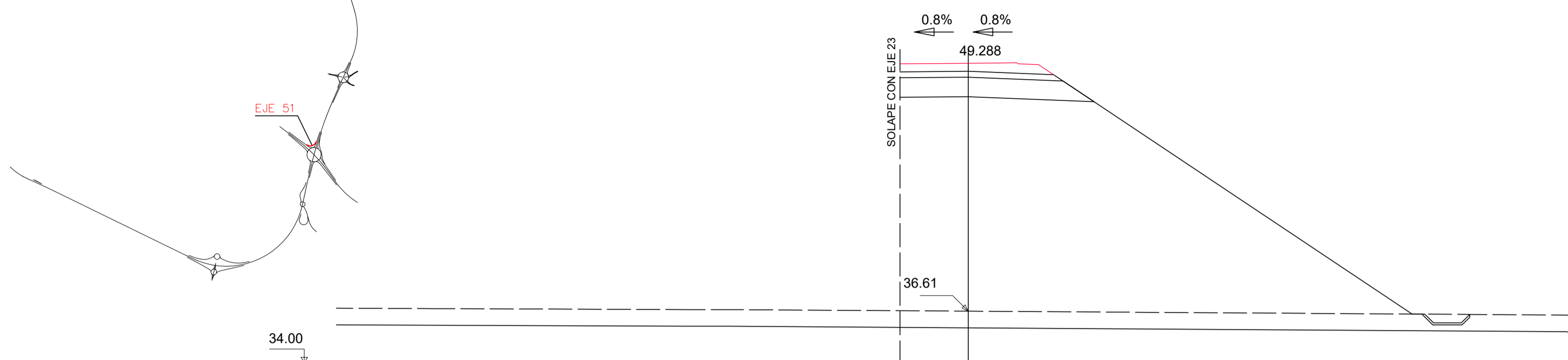

Pk=0+000
 S. FIRME = 3.33 m² S. REV CUN GUARDA = 0.28 m².
 S. SUELO ADEC = 9.15 m² S. VEGETAL = 24.80 m².
 S. SUELO S-EST3 = 2.43 m².
 S. TERRAPLEN = 219.54 m².

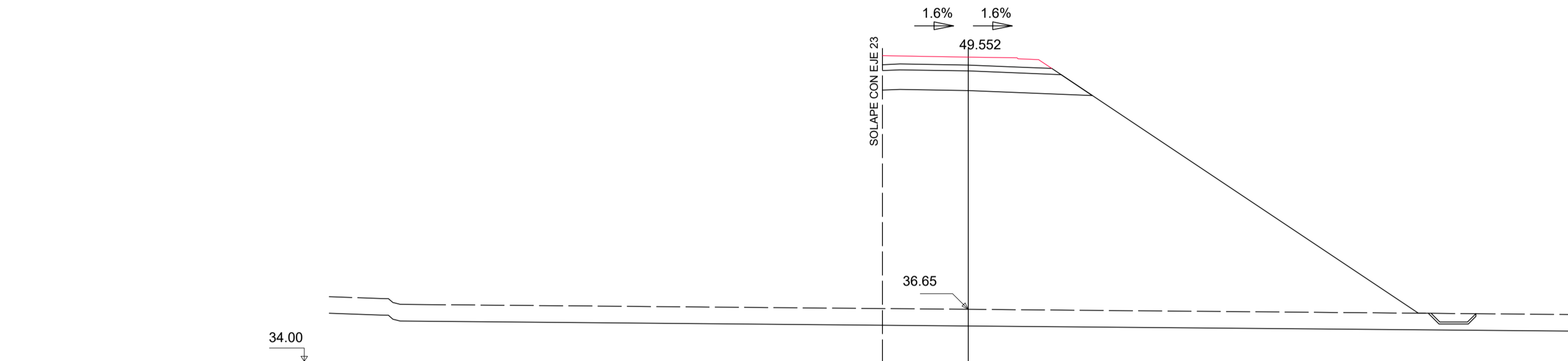

Pk=0+020
 S. FIRME = 3.53 m² S. REV CUN GUARDA = 0.27 m².
 S. SUELO ADEC = 9.95 m² S. VEGETAL = 25.82 m².
 S. SUELO S-EST3 = 2.67 m².
 S. TERRAPLEN = 236.12 m².

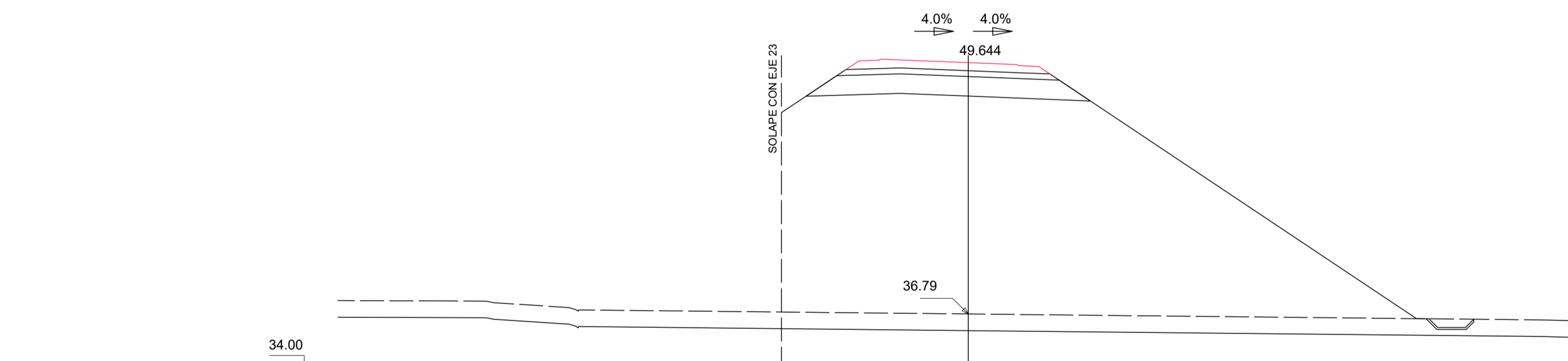

Pk=0+040
 S. FIRME = 4.02 m² S. REV CUN GUARDA = 0.27 m².
 S. SUELO ADEC = 12.97 m² S. VEGETAL = 30.13 m².
 S. SUELO S-EST3 = 3.27 m².
 S. TERRAPLEN = 295.75 m².

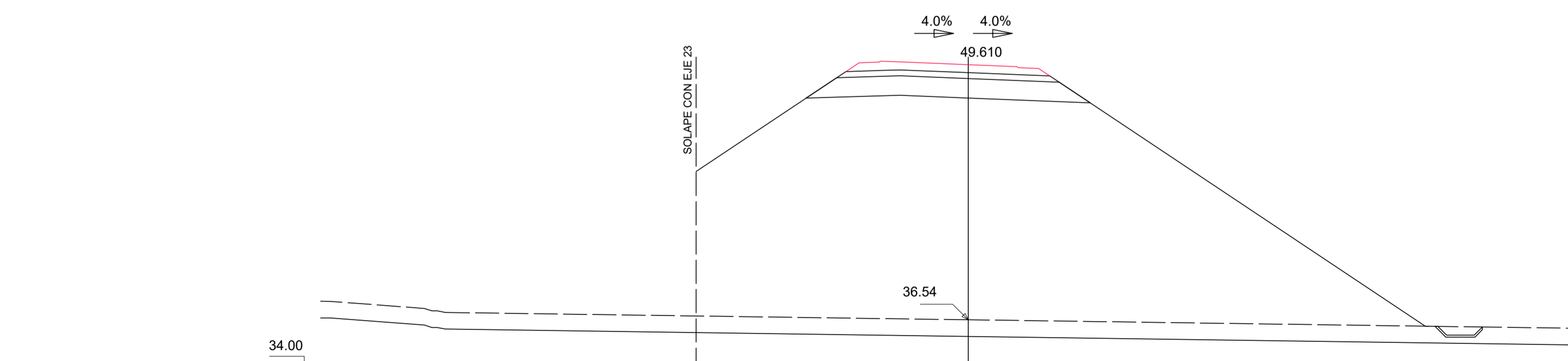

Pk=0+060
 S. FIRME = 4.02 m² S. REV CUN GUARDA = 0.27 m².
 S. SUELO ADEC = 12.97 m² S. VEGETAL = 34.22 m².
 S. SUELO S-EST3 = 3.27 m².
 S. TERRAPLEN = 346.45 m².

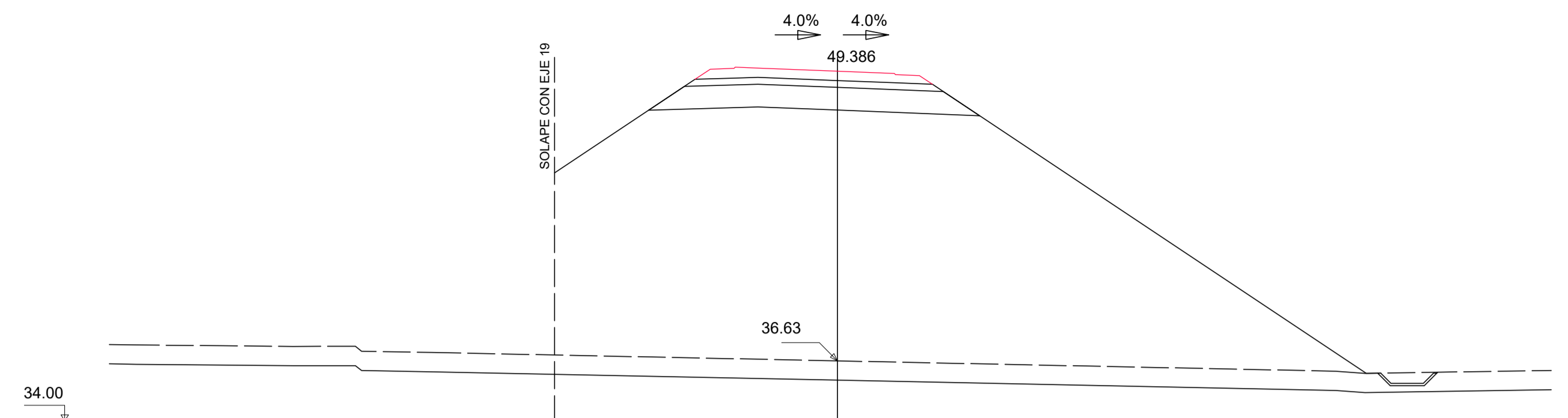

Pk=0+080
 S. FIRME = 4.02 m² S. REV CUN GUARDA = 0.29 m².
 S. SUELO ADEC = 12.97 m² S. VEGETAL = 33.03 m².
 S. SUELO S-EST3 = 3.27 m².
 S. TERRAPLEN = 323.68 m².

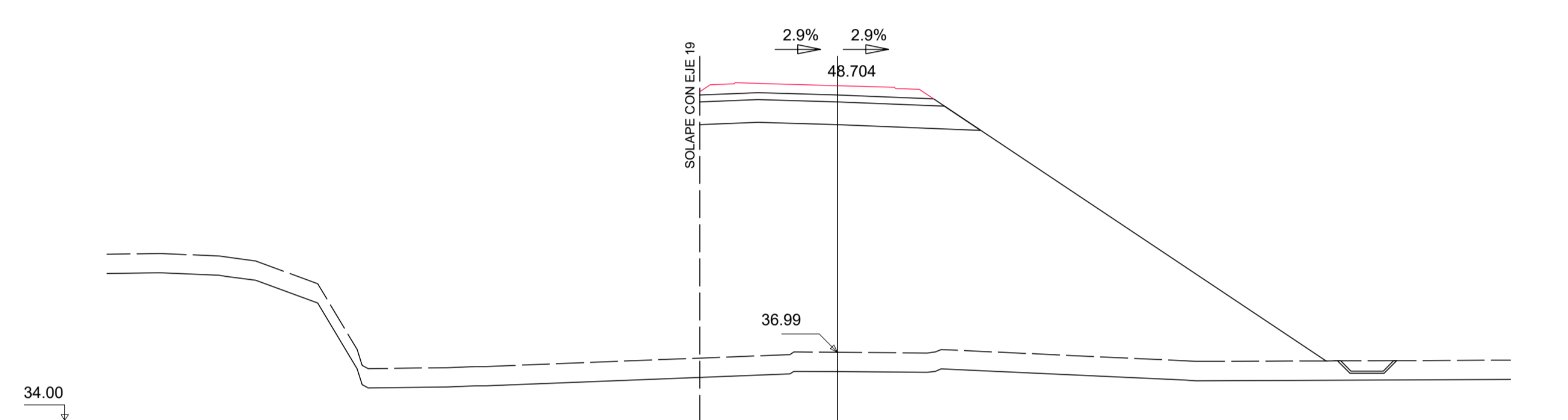

Pk=0+100
 S. FIRME = 4.10 m² S. REV CUN GUARDA = 0.29 m².
 S. SUELO ADEC = 11.56 m² S. VEGETAL = 26.07 m².
 S. SUELO S-EST3 = 3.16 m².
 S. TERRAPLEN = 223.85 m².

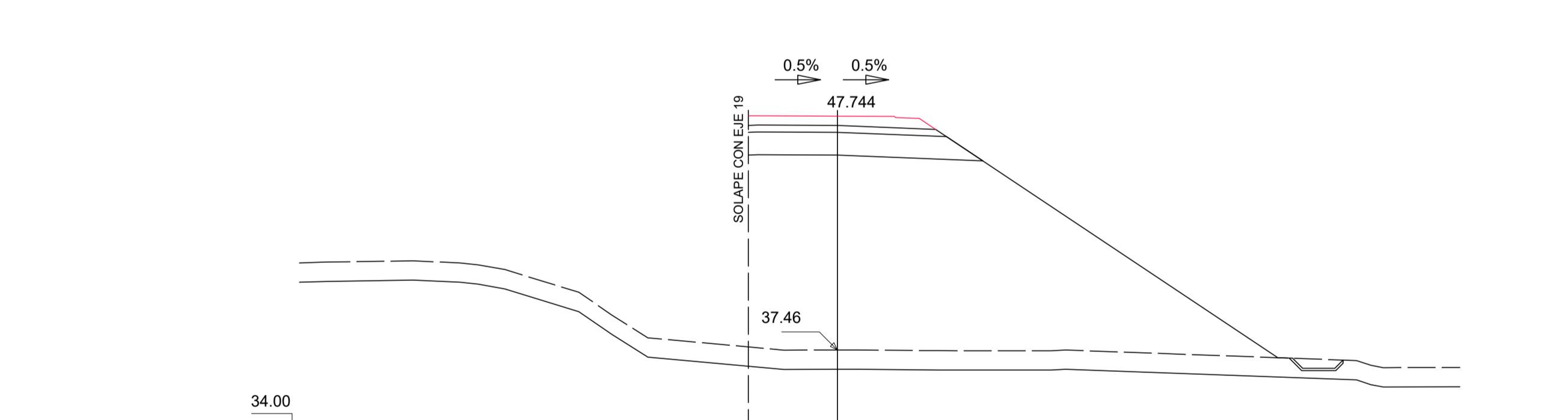

Pk=0+120
 S. FIRME = 3.41 m² S. REV CUN GUARDA = 0.27 m².
 S. SUELO ADEC = 9.52 m² S. VEGETAL = 22.24 m².
 S. SUELO S-EST3 = 2.54 m².
 S. TERRAPLEN = 162.32 m².

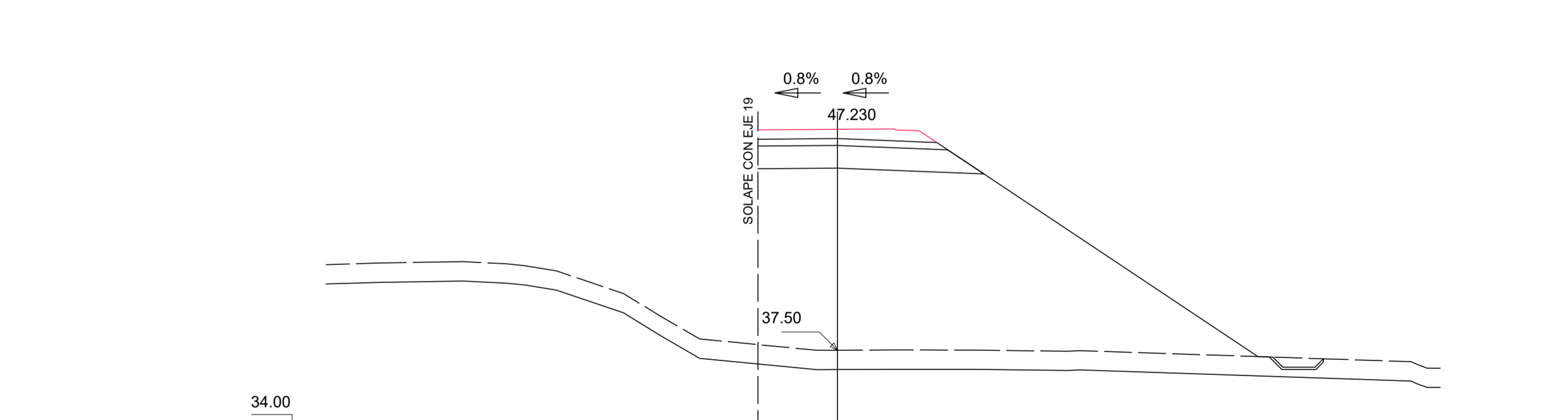

Pk=0+130.668
 S. FIRME = 3.33 m² S. REV CUN GUARDA = 0.27 m².
 S. SUELO ADEC = 9.15 m² S. VEGETAL = 21.15 m².
 S. SUELO S-EST3 = 2.43 m².
 S. TERRAPLEN = 144.94 m².

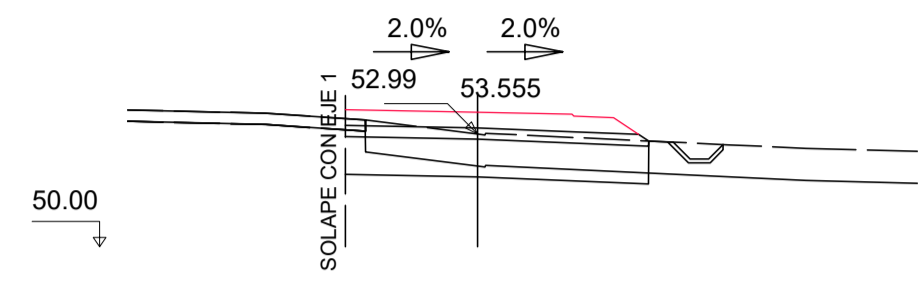
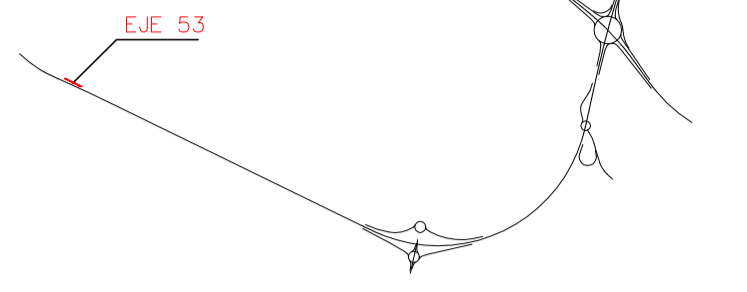

Pk=0+000

S. FIRME = 3.11 m2.	S. TERRAPLEN = 1.13 m2.
S. D TIERRA = 3.29 m2.	S. REV CUN GUARDA = 0.18 m2.
S. SUELO ADEC = 8.02 m2.	S. VEGETAL = 8.04 m2.
S. SUELO S-EST3 = 2.38 m2.	S. DEMOLICION = 0.16 m2.

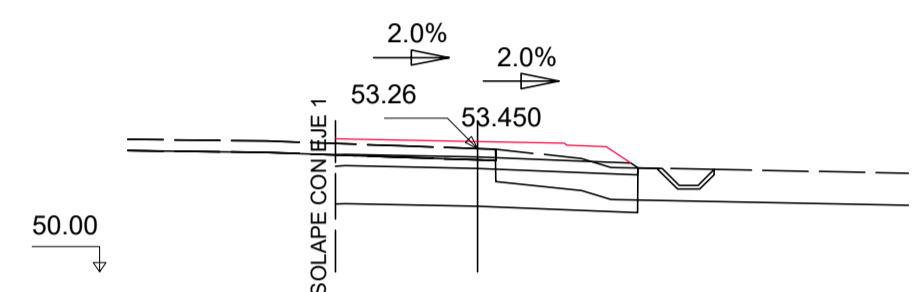

Pk=0+020

S. FIRME = 3.13 m2.	S. TERRAPLEN = 1.13 m2.
S. D TIERRA = 7.21 m2.	S. REV CUN GUARDA = 0.18 m2.
S. SUELO ADEC = 8.00 m2.	S. VEGETAL = 4.91 m2.
S. SUELO S-EST3 = 2.39 m2.	S. DEMOLICION = 1.27 m2.

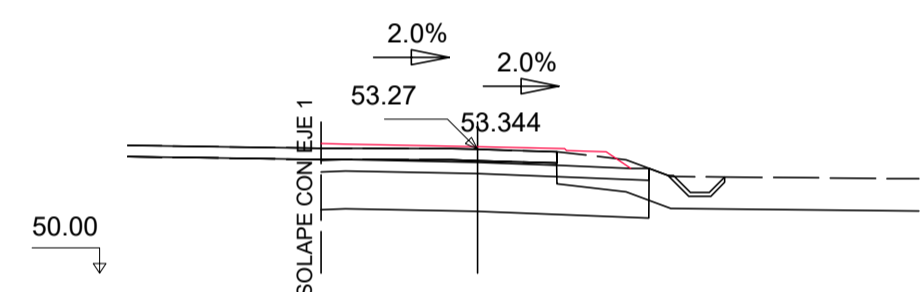

Pk=0+040

S. FIRME = 3.29 m2.	S. TERRAPLEN = 1.14 m2.
S. D TIERRA = 10.02 m2.	S. REV CUN GUARDA = 0.18 m2.
S. SUELO ADEC = 8.67 m2.	S. VEGETAL = 3.77 m2.
S. SUELO S-EST3 = 2.61 m2.	S. DEMOLICION = 1.87 m2.

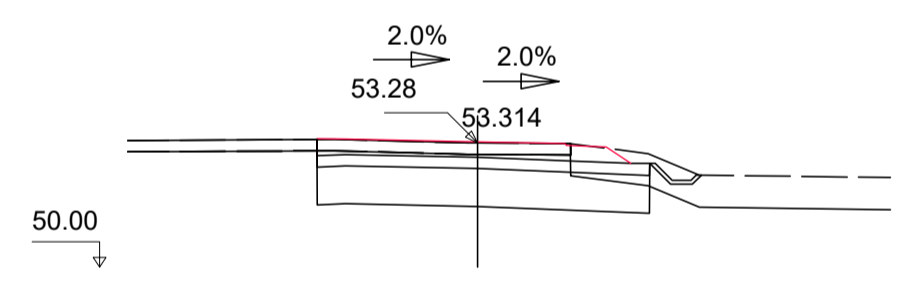

Pk=0+060

S. FIRME = 3.34 m2.	S. SUELO S-EST3 = 2.64 m2.
S. REVES CUNETTA = 0.15 m2.	S. TERRAPLEN = 0.00 m2.
S. D TIERRA = 11.09 m2.	S. VEGETAL = 2.29 m2.
S. SUELO ADEC = 8.80 m2.	S. DEMOLICION = 2.02 m2.

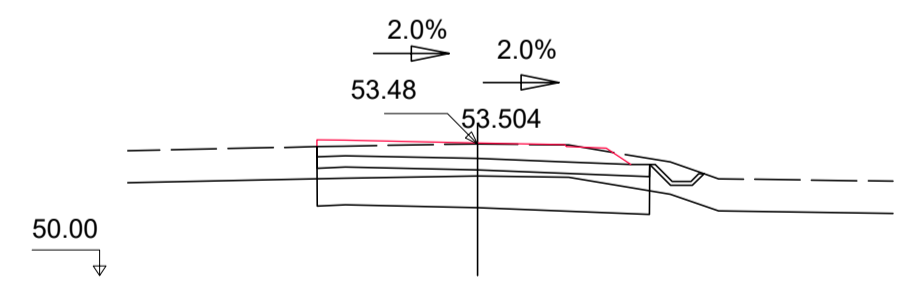

Pk=0+075

S. FIRME = 3.34 m2.	S. SUELO S-EST3 = 2.64 m2.
S. REVES CUNETTA = 0.16 m2.	S. TERRAPLEN = 0.00 m2.
S. D TIERRA = 6.96 m2.	S. VEGETAL = 8.06 m2.
S. SUELO ADEC = 8.80 m2.	